

# Eaton® 93E External Battery Cabinet

30EBC and 60EBC  
Installation Manual



*Powering Business Worldwide*



# Eaton® 93E External Battery Cabinet

30EBC and 60EBC  
Installation Manual



*Powering Business Worldwide*

---

**IMPORTANT SAFETY INSTRUCTIONS SAVE THESE INSTRUCTIONS**

---

This manual contains important instructions that should be followed during installation and maintenance of the UPS and batteries. Read all instructions before operating the equipment and save this manual for future reference.

---

---

**CONSIGNES DE SÉCURITÉ IMPORTANTES CONSERVER CES INSTRUCTIONS**

---

Ce manuel comporte des instructions importantes que vous êtes invité à suivre lors de toute procédure d'installation et de maintenance des batteries et de l'onduleur. Veuillez consulter entièrement ces instructions avant de faire fonctionner l'équipement et conserver ce manuel afin de pouvoir vous y reporter ultérieurement.

---

Eaton is a registered trademarks of Eaton Corporation or its subsidiaries and affiliates. National Electrical Code and NEC are registered trademarks of National Fire Protection Association, Inc. All other trademarks are property of their respective companies.

©Copyright 2011–2015 Eaton Corporation, Raleigh, NC, USA. All rights reserved. No part of this document may be reproduced in any way without the express written approval of Eaton Corporation.

# Table of Contents

<b>1</b>	<b>INTRODUCTION</b>	<b>1-1</b>
1.1	Installation Features	1-2
1.2	Model Configurations	1-2
1.3	EBC Options	1-2
1.4	Using This Manual	1-4
1.5	Conventions Used in This Manual	1-4
1.6	Symbols, Controls, and Indicators	1-4
1.7	For More Information	1-5
1.8	Getting Help	1-5
<b>2</b>	<b>SAFETY WARNINGS</b>	<b>2-1</b>
<b>3</b>	<b>INSTALLATION PLAN AND UNPACKING</b>	<b>3-1</b>
3.1	Creating an Installation Plan	3-1
3.2	Preparing the Site	3-1
3.2.1	Environmental and Installation Considerations	3-1
3.2.2	EBC Power Wiring Preparation	3-9
3.3	Battery Type	3-10
3.4	Inspecting and Unpacking the EBC	3-11
3.5	Battery Breaker Location	3-13
<b>4</b>	<b>INSTALLATION</b>	<b>4-1</b>
4.1	Preliminary Installation Information	4-1
4.2	Unloading the EBC Cabinet from the Pallet	4-1
4.2.1	Unloading the 30EBC	4-1
4.2.2	Unloading the 60EBC	4-5
4.3	Installing Power Terminal Cover Base	4-8
4.4	Installing EBC External Power Wiring	4-9
4.5	Initial Startup	4-18
4.6	Completing the Installation Checklist	4-18
<b>5</b>	<b>ONELINES AND SCHEMATICS</b>	<b>5-1</b>
5.1	Onelines	5-1
5.2	Schematics	5-2
<b>6</b>	<b>MAINTENANCE</b>	<b>6-1</b>
6.1	Important Safety Instructions	6-1
6.2	Performing Preventive Maintenance	6-1
6.2.1	DAILY Maintenance	6-1
6.2.2	PERIODIC Maintenance	6-1
6.2.3	ANNUAL Maintenance	6-1
6.2.4	BATTERY Maintenance	6-1
6.3	Recycling the Used Batteries	6-2
6.4	Maintenance Training	6-2

Table of Contents

- 7    PRODUCT SPECIFICATIONS ..... 7-1**
- 7.1    Model Numbers ..... 7-1
- 7.2    Specifications ..... 7-1
- 7.2.1    Battery Specifications ..... 7-1
- 7.2.2    Battery Runtimes (in Minutes) at Full load ..... 7-2
- 7.2.3    Environmental and Safety Specifications ..... 7-2
- WARRANTY ..... W-1**

## List of Figures

Figure 1-1.	Eaton 93E 30EBC and Eaton 93E 60EBC . . . . .	1-1
Figure 1-2.	Eaton 93E 30 kVA UPS and Two Eaton 93E 30EBCs . . . . .	1-3
Figure 1-3.	Eaton 93E 60 kVA UPS and Two Eaton 93E 60EBCs . . . . .	1-3
Figure 3-1.	93E 30EBC Cabinet Dimensions (Front, Right Side, and Rear Views) . . . . .	3-3
Figure 3-2.	93E 30EBC Dimensions (Top and Bottom Views). . . . .	3-4
Figure 3-3.	93E 30EBC Center of Gravity . . . . .	3-5
Figure 3-4.	93E 60EBC Cabinet Dimensions (Front, Right Side, and Rear Views) . . . . .	3-6
Figure 3-5.	93E 60EBC Dimensions (Top and Bottom Views). . . . .	3-7
Figure 3-6.	93E 60EBC Center of Gravity . . . . .	3-8
Figure 3-7.	Eaton 93E 30EBC and Eaton 93E 60EBC as Shipped on Pallet. . . . .	3-12
Figure 3-8.	Eaton 93E 30EBC and Eaton 93E 60EBC Battery Breaker Locations – Front Views with Doors Removed . . . . .	3-13
Figure 4-1.	Removing the Front Shipping Bracket – 93E 30EBC. . . . .	4-2
Figure 4-2.	Removing the Rear Shipping Bracket – 93E 30EBC . . . . .	4-3
Figure 4-3.	Installing the Pallet Extension Plate – 93E 30EBC. . . . .	4-4
Figure 4-4.	Removing the Pallet Skids and Supports – 93E 60EBC. . . . .	4-7
Figure 4-5.	EBC Power Terminal Cover Parts . . . . .	4-8
Figure 4-6.	EBC Power Terminal Cover Base Installation and Conduit Wire Entry Location. . . . .	4-9
Figure 4-7.	DC Power Terminal Locations – 93E 30EBC. . . . .	4-12
Figure 4-8.	DC Power Terminal Detail – 93E 30EBC . . . . .	4-13
Figure 4-9.	DC Power Terminal Locations – 93E 60EBC. . . . .	4-14
Figure 4-10.	DC Power Terminal Detail – 93E 60EBC . . . . .	4-14
Figure 4-11.	EBC and UPS Power Terminal Cover Base Wiring Channel . . . . .	4-15
Figure 4-12.	EBC Power Terminal Cover Installation. . . . .	4-16
Figure 4-13.	EBC Power Terminal Cover Splice Installation . . . . .	4-17
Figure 5-1.	EBC Internal Oneline . . . . .	5-1
Figure 5-2.	EBC Intercabinet Interconnection Online . . . . .	5-1
Figure 5-3.	93E 30 EBC Schematic . . . . .	5-2
Figure 5-4.	93E 60 EBC Schematic . . . . .	5-3

This page intentionally left blank.



## List of Tables

Table 3-1.	EBC Cabinet Weights . . . . .	3-2
Table 3-2.	EBC Cabinet Clearances . . . . .	3-2
Table 3-3.	External Power Wiring Requirements for the Eaton 93E 30EBC and 60EBC . . . . .	3-9
Table 3-4.	External Power Cable Terminations for the Eaton 93E 30EBC and 60EBC. . . . .	3-10
Table 3-5.	Recommended DC Circuit Breaker or Disconnect Ratings . . . . .	3-10
Table 3-6.	Battery Type . . . . .	3-10

This page intentionally left blank.

## Chapter 1 Introduction

The Eaton® External Battery Cabinet (EBC) provides extended emergency short-term backup power for the 93E 20–30 kVA and 40–60 kVA UPS to enhance the usability and reliability of the systems. The EBC safeguards operation during brownouts, blackouts, and other power interruptions providing cost-effective extended battery run time. Two models are available, the 93E 30EBC and 93E 60EBC and are equipped with valve-regulated lead-acid (VRLA) batteries.

The EBC is housed in a single free-standing cabinet with safety shields behind the doors for hazardous voltage protection. Up to two EBCs per UPS may be used to meet application runtime needs. The cabinets match the UPS cabinet in style and color.

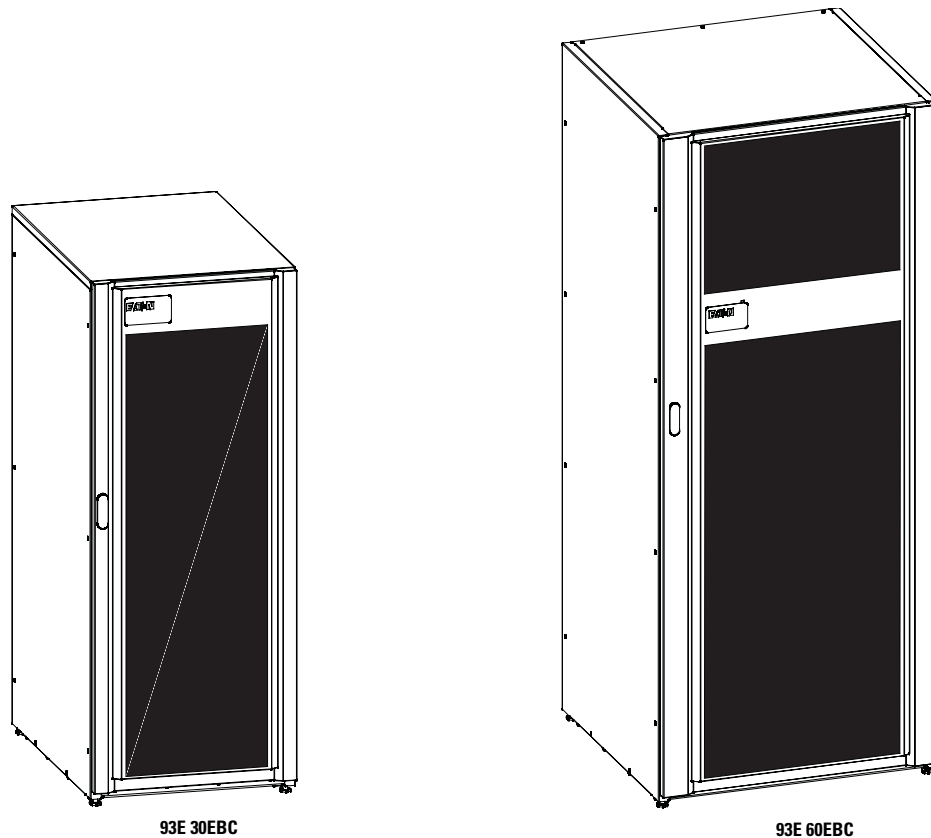
Mechanical lugs located at the back of the cabinet reduce installation time, and removable battery trays with quick disconnects between trays reduce battery maintenance time. A DC-rated circuit breaker within each cabinet provides protection and servicing isolation.

Figure 1-1 shows the Eaton 93E 30EBC and Eaton 93E 60EBC.

---

**NOTE** Startup and operational checks must be performed by an authorized Eaton Customer Service Engineer, or the warranty terms specified on page W-1 become void. This service is offered as part of the sales contract for the UPS. Contact an Eaton service representative in advance (usually a two-week notice is required) to reserve a preferred startup date.

---



**Figure 1-1. Eaton 93E 30EBC and Eaton 93E 60EBC**

## 1.1 Installation Features



**NOTE** External battery cabinets cannot be used in combination with a UPS containing internal batteries. The UPS must be supplied without internal batteries.

---

The EBC is designed to be installed in a line-up-and-match or standalone configurations. In line-up-and-match configurations power wiring may be routed either external to the cabinet using conduit or the power terminal wiring channel assembly may be utilized to pass wiring between adjacent cabinets. In standalone configurations power wiring is routed using external conduit. Connections are made to easily accessible terminals at the back of the cabinet.

Line-up-and-match battery cabinets are installed adjacent to the UPS. The recommended installation location is on the right side of the UPS cabinet. See Figure 1-2 and Figure 1-3 for line-up-and-match configuration views.

## 1.2 Model Configurations

The following model configurations are available:

- 93E 30EBC
  - Contains two or three battery strings to be used with the 93E 30 kVA UPS.
  - Up to two EBCs with a total of four or six battery strings can be paralleled together to extend the run time.



**NOTE** To configure a 30EBC battery system with four strings, two 30EBCs, each with two strings, must be used.

---

- 93E 60EBC
  - Contains four or six battery strings to be used with the 93E 60 kVA UPS.
  - Up to two EBCs with a total of eight, ten, or twelve battery strings can be paralleled together to extend the run time.



**NOTE** To configure a 60EBC battery system with eight strings, two 60EBCs, each with four strings, must be used.

---

## 1.3 EBC Options

Battery string kits are available to upgrade each 93E 30 EBC from two strings to three strings and each 93E 60 EBC from four strings to six strings. Kits must be installed by an authorized Eaton Customer Service Engineer. Contact an Eaton sales representative for information.

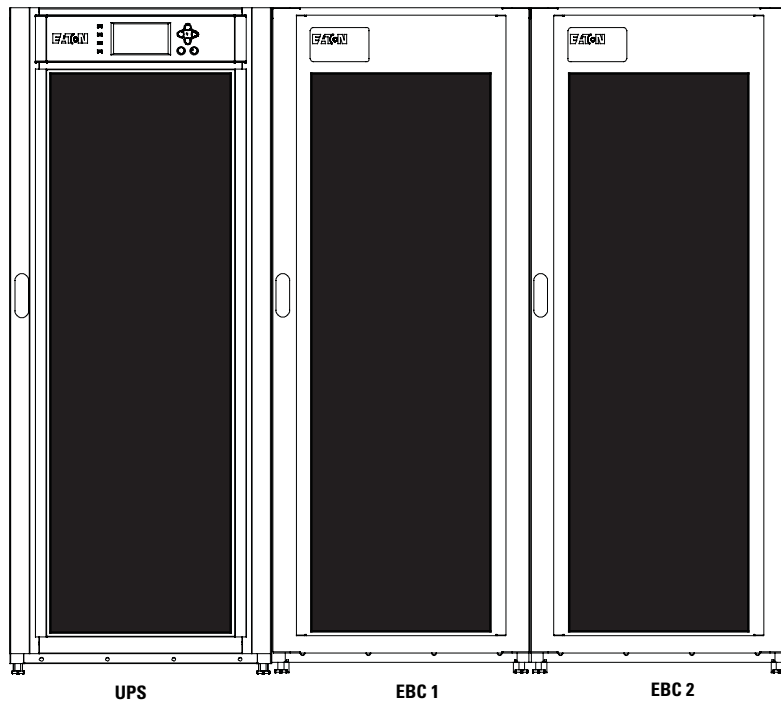


Figure 1-2. Eaton 93E 30 kVA UPS and Two Eaton 93E 30EBCs

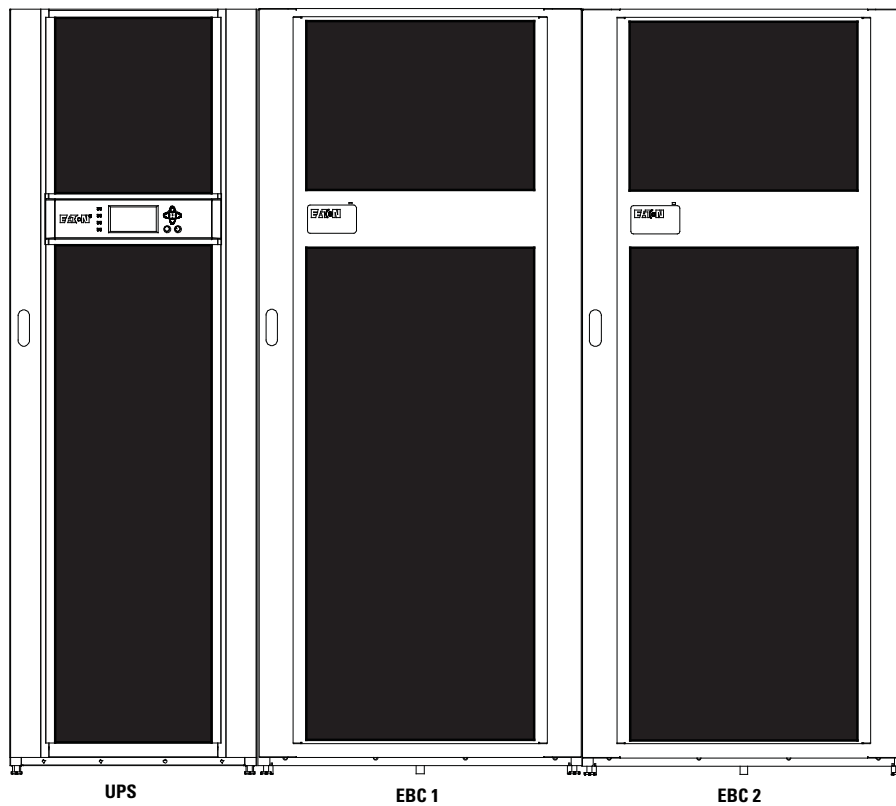


Figure 1-3. Eaton 93E 60 kVA UPS and Two Eaton 93E 60EBCs

## 1.4 Using This Manual

This manual describes how to install the EBC and is divided into chapters. Read and understand the procedures described to ensure trouble-free installation and operation.

Read through each procedure before beginning the procedure. Perform only those procedures that apply to the UPS system being installed or operated.

## 1.5 Conventions Used in This Manual

This manual uses these type conventions:

- **Bold type** highlights important concepts in discussions, key terms in procedures, and menu options, or represents a command or option that you type or enter at a prompt.
- *Italic type* highlights notes and new terms where they are defined.
- `Screen type` represents information that appears on the screen or LCD.

Icon	Description
<b>Note</b>	Information notes call attention to important features or instructions.
[Keys]	Brackets are used when referring to a specific key, such as [Enter] or [Ctrl].

In this manual, the term UPS refers only to the UPS cabinet and its internal elements. The term UPS system refers to the entire power protection system – the UPS cabinet, an external battery system, and options or accessories installed.

The term line-up-and-match refers to accessory cabinets that are physically located adjacent to the UPS. The term standalone refers to accessory cabinets that are located separate from the UPS.

## 1.6 Symbols, Controls, and Indicators

The following are examples of symbols used on the UPS or accessories to alert you to important information:



**RISK OF ELECTRIC SHOCK** - Observe the warning associated with the risk of electric shock symbol.



**CAUTION: REFER TO OPERATOR'S MANUAL** - Refer to your operator's manual for additional information, such as important operating and maintenance instructions.



This symbol indicates that you should not discard the UPS or the UPS batteries in the trash. This product contains sealed, lead-acid batteries and must be disposed of properly. For more information, contact your local recycling/reuse or hazardous waste center.



This symbol indicates that you should not discard waste electrical or electronic equipment (WEEE) in the trash. For proper disposal, contact your local recycling/reuse or hazardous waste center.

## 1.7 For More Information

Refer to the Eaton 93E UPS (20-30 kVA, 208/220V) Installation and Operation Manual or Eaton 93E UPS (40-60 kVA, 208/220V) Installation and Operation Manual for the following additional information:

- UPS, optional components, and accessory installation instructions, including site preparation, planning for installation, and wiring and safety information. Detailed illustrations of cabinets and optional accessories with dimensional and connection point drawings are provided.
- UPS operation, including UPS controls, functions of the UPS, standard features and optional accessories, procedures for starting and stopping the UPS, and information about maintenance and responding to system events.
- Communication capabilities of the UPS system.

Visit [www.eaton.com/powerquality](http://www.eaton.com/powerquality) or contact an Eaton service representative for information on how to obtain copies of these manuals.

## 1.8 Getting Help

If help is needed with any of the following:

- Scheduling initial startup
- Regional locations and telephone numbers
- A technical question about any of the information in this manual
- A question this manual does not answer

Please call the Customer Reliability Center at:

United States:	<b>1-800-843-9433</b>
Canada:	<b>1-800-461-9166 ext 260</b>
All other countries:	<b>Call your local service representative</b>

Please use the following e-mail address for manual comments, suggestions, or to report an error in this manual:

**[E-ESSDocumentation@eaton.com](mailto:E-ESSDocumentation@eaton.com)**

This page intentionally left blank.



## Chapter 2 Safety Warnings

---

### IMPORTANT SAFETY INSTRUCTIONS SAVE THESE INSTRUCTIONS

---

This manual contains important instructions that should be followed during installation and maintenance of the UPS system and batteries. Read all instructions before operating the equipment and save this manual for future reference.

---

The UPS system is designed for industrial or computer room applications, and contains safety shields behind the door and front panels. However, the UPS system is a sophisticated power system and should be handled with appropriate care.

---

#### **DANGER**

---

This UPS system contains LETHAL VOLTAGES. All repairs and service should be performed by AUTHORIZED SERVICE PERSONNEL ONLY. There are NO USER SERVICEABLE PARTS inside the UPS.

---

#### **WARNING**

---

- The UPS system is powered by its own energy source (batteries). The output terminals may carry live voltage even when the UPS is disconnected from an AC source.
  - The battery cabinet contains its own energy source. The internal wiring and output terminals may carry live voltage even when the UPS is not connected to an AC source.
  - To reduce the risk of fire or electric shock, install this UPS system in a temperature and humidity controlled, indoor environment, free of conductive contaminants. Ambient temperature must not exceed 30°C (86°F). Do not operate near water or excessive humidity (95% maximum). The system is not intended for outdoor use.
  - As a result of the connected loads high leakage current is possible. Connection to earth ground is required for safety and proper product operation. Do not check UPS system operation by any action that includes removal of the earth (ground) connection with loads attached.
  - Ensure all power is disconnected before performing installation or service.
  - Batteries can present a risk of electrical shock or burn from high short-circuit current. The following precautions should be observed: 1) Remove watches, rings, or other metal objects; 2) Use tools with insulated handles; 3) Do not lay tools or metal parts on top of batteries; 4) Wear rubber gloves and boots.
  - ELECTRIC ENERGY HAZARD. Do not attempt to alter any UPS system or battery wiring or connectors. Attempting to alter wiring can cause injury.
  - Do not open or mutilate batteries. Released electrolyte is harmful to the skin and eyes. It may be toxic.
- 

#### **CAUTION**

---

- Installation or servicing should be performed by qualified service personnel knowledgeable of UPS and battery systems, and required precautions. Keep unauthorized personnel away from equipment. Consider all warnings, cautions, and notes before installing or servicing equipment. DO NOT DISCONNECT the batteries while the UPS is in Battery mode.
  - Batteries may only be replaced with the same number and type by authorized service personnel. No user serviceable parts.
-

- The UPS system has been evaluated for use with a maximum of two 93E EBCs. Use of any other configuration may result in fire, death, and voiding of the warranty.
- Disconnect the charging source prior to connecting or disconnecting battery terminals.
- Determine if the battery is inadvertently grounded. If it is, remove the source of the ground. Contacting any part of a grounded battery can cause a risk of electric shock. An electric shock is less likely if you disconnect the grounding connection before you work on the batteries.
- Proper disposal of batteries is required. Refer to local codes for disposal requirements.
- Do not dispose of batteries in a fire. Batteries may explode when exposed to flame.
- Keep the Accessory cabinet doors closed and front panels installed to ensure proper cooling airflow and to protect personnel from dangerous voltages inside the unit.
- Do not install or operate the UPS system close to gas or electric heat sources.
- Lead-acid batteries can present a risk of fire because they generate hydrogen gas. Do not smoke when near batteries. Do not cause flame or spark in battery area. Discharge static electricity from body before touching batteries by first touching a grounded metal surface.
- The operating environment should be maintained within the parameters stated in this manual.
- Operating temperatures above the recommended range will result in decreased battery life and performance, and will reduce or void the battery warranty. Refer to Terms and Conditions of Sale with Battery Replacement Coverage and the Battery Replacement Price Book for more information. These documents can be found at [www.eaton.com/powerquality](http://www.eaton.com/powerquality) or contact your service representative for information on how to obtain copies.
- Keep surroundings uncluttered, clean, and free from excess moisture.
- Observe all DANGER, CAUTION, and WARNING notices affixed to the inside and outside of the equipment.

---

---

 **AVERTISSEMENT!**

---

- Les batteries peuvent présenter un risque de décharge électrique ou de brûlure par des courts-circuits de haute intensité. Prendre les précautions nécessaires.
- Pour le remplacement, utiliser le même nombre et modèle des batteries.

---

---

 **ATTENTION!**

---

- Une mise au rebut réglementaire des batteries est obligatoire. Consulter les règlements en vigueur dans votre localité.
  - Ne jamais jeter les batteries au feu. L'exposition aux flammes risque de les faire exploser.
  - Les accumulateurs au plomb-acide peuvent représenter un risque d'incendie, car ils génèrent de l'hydrogène gazeux. Ne pas fumer près des accumulateurs. Ne pas produire de flamme ou d'étincelle dans la zone de l'accumulateur. Dissiper l'électricité statique de votre corps en touchant une surface reliée à la terre avant de toucher les accumulateurs.
-

## Chapter 3 Installation Plan and Unpacking

**Use the following basic sequence of steps to install the Eaton 93E 30 or 60 External Battery Cabinet (EBC):**

1. Create an installation plan for the EBC.
2. Prepare your site for the EBC.
3. Inspect and unpack the EBC.
4. Unload and install the EBC, and wire the system.
5. Complete the Installation Checklist.
6. Have authorized service personnel perform preliminary operational checks and start up the system.




---

**NOTE** Startup and operational checks must be performed by an authorized Eaton Customer Service Engineer, or the warranty terms specified on page W-1 become void. This service is offered as part of the sales contract for the UPS. Contact an Eaton service representative in advance (usually a two-week notice is required) to reserve a preferred startup date.

---

### 3.1 Creating an Installation Plan

Before installing the EBC, read and understand how this manual applies to the system being installed. Use the procedures and illustrations in this section to create a logical plan for installing the EBC. This section contains the following information:

- Physical features and requirements, including dimensions
- Power wiring installation notes
- Location of conduit and wire entry landing plates
- Location of power terminals

### 3.2 Preparing the Site

For the UPS system to operate at peak efficiency, the installation site should meet the environmental parameters outlined in this manual. If the UPS system is to be operated at an altitude higher than 1500m (5000 ft), contact an Eaton service representative for important information about high altitude operation. The operating environment must meet the weight, clearance, and environmental requirements specified for the applicable accessory cabinet.

#### 3.2.1 Environmental and Installation Considerations

The UPS system installation, including the EBC, must meet the following guidelines:

- The system must be installed on a level floor suitable for computer or electronic equipment.
- The system must be installed in a temperature and humidity controlled indoor area free of conductive contaminants.

Failure to follow guidelines may void your warranty.

The EBC operating environment must meet the weight requirements shown in Table 3-1 and the size requirements shown in Figure 3-1 through Figure 3-6. Dimensions are in millimeters (inches).

**Table 3-1. EBC Cabinet Weights**

Model	Strings	Weight kg (lb)		
		Shipping	Installed	Point Loading
Eaton 93E 30EBC	2	561 (1237)	536 (1182)	8 at 77 (170)
	3	744 (1640)	719 (1585)	8 at 100 (220)
Eaton 93E 60EBC	4	779 (2788)	1231 (2713)	12 at 165 (363)
	6	1448 (3192)	1414 (3117)	12 at 180 (397)

The EBC cabinet uses convection cooling to regulate internal component temperature. Air inlets are in the front of the cabinet and outlets are in the back of the cabinet. Allow clearance in front of and in back of the cabinet for proper air circulation. The clearances required around the EBC cabinet are shown in Table 3-2.

**Table 3-2. EBC Cabinet Clearances**

<b>From Top of Cabinet</b>	304.8 mm (12") working space
<b>From Front of Cabinet</b>	914.4 mm (36") working space
<b>From Back of Cabinet</b>	914.4 mm (36") working space
<b>From Right Side of Cabinet</b>	None Required
<b>From Left Side of Cabinet</b>	None Required

The basic environmental requirements for operation of the EBC are:

- Recommended Operating Range: 15–25°C (59–77°F)
- Maximum Relative Humidity: 95%, noncondensing

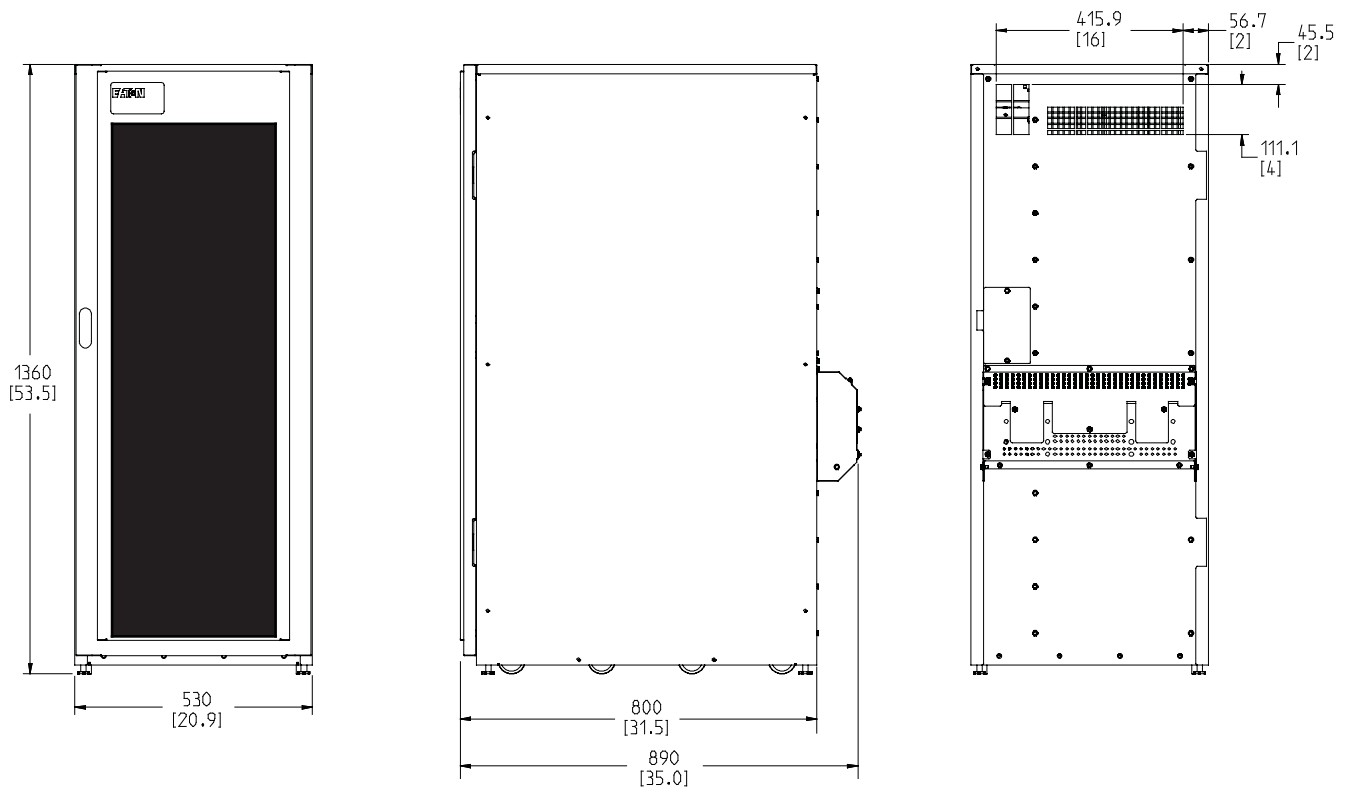
---

 **CAUTION**

---

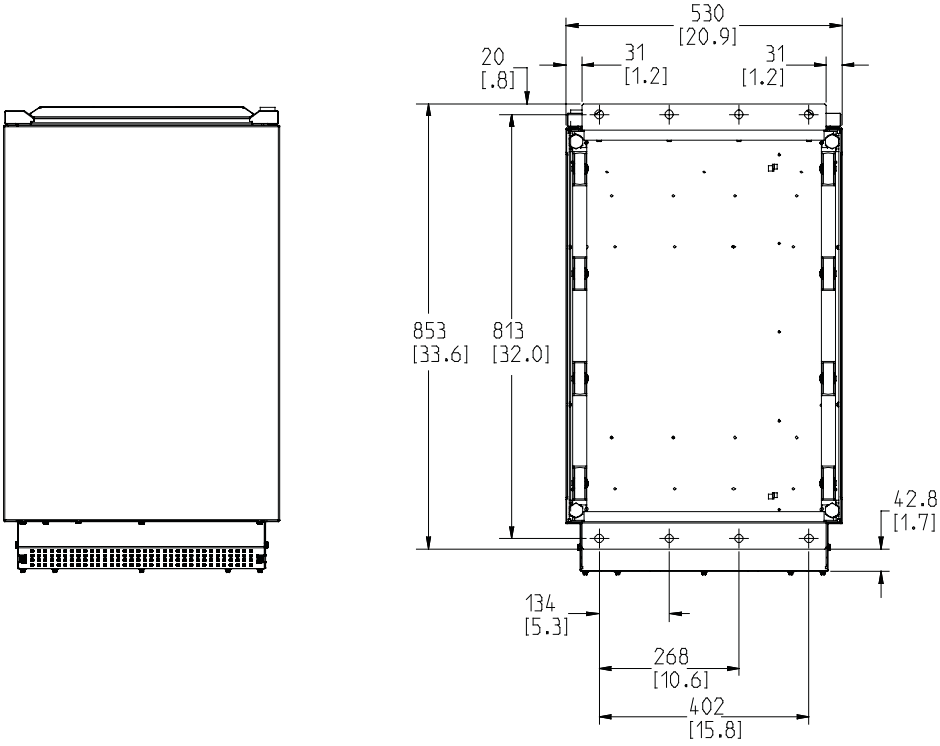
Operating temperatures above the recommended range will result in decreased battery life and performance, and will reduce or void the battery warranty. Refer to Eaton's Terms and Conditions of Sale with Battery Replacement Coverage and the Battery Replacement Price Book for more information. These documents can be found at [www.eaton.com/powerquality](http://www.eaton.com/powerquality) or contact your service representative for information on how to obtain copies.

---



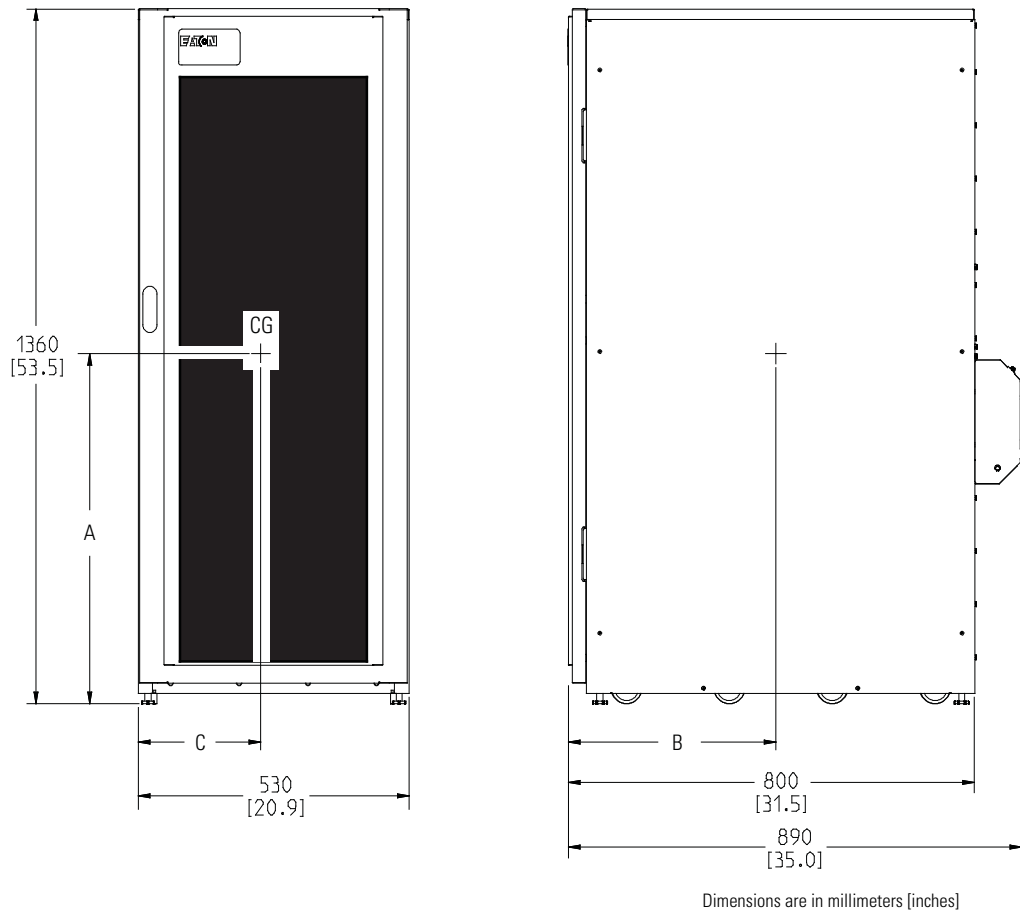
Dimensions are in millimeters [inches]

**Figure 3-1. 93E 30EBC Cabinet Dimensions (Front, Right Side, and Rear Views)**



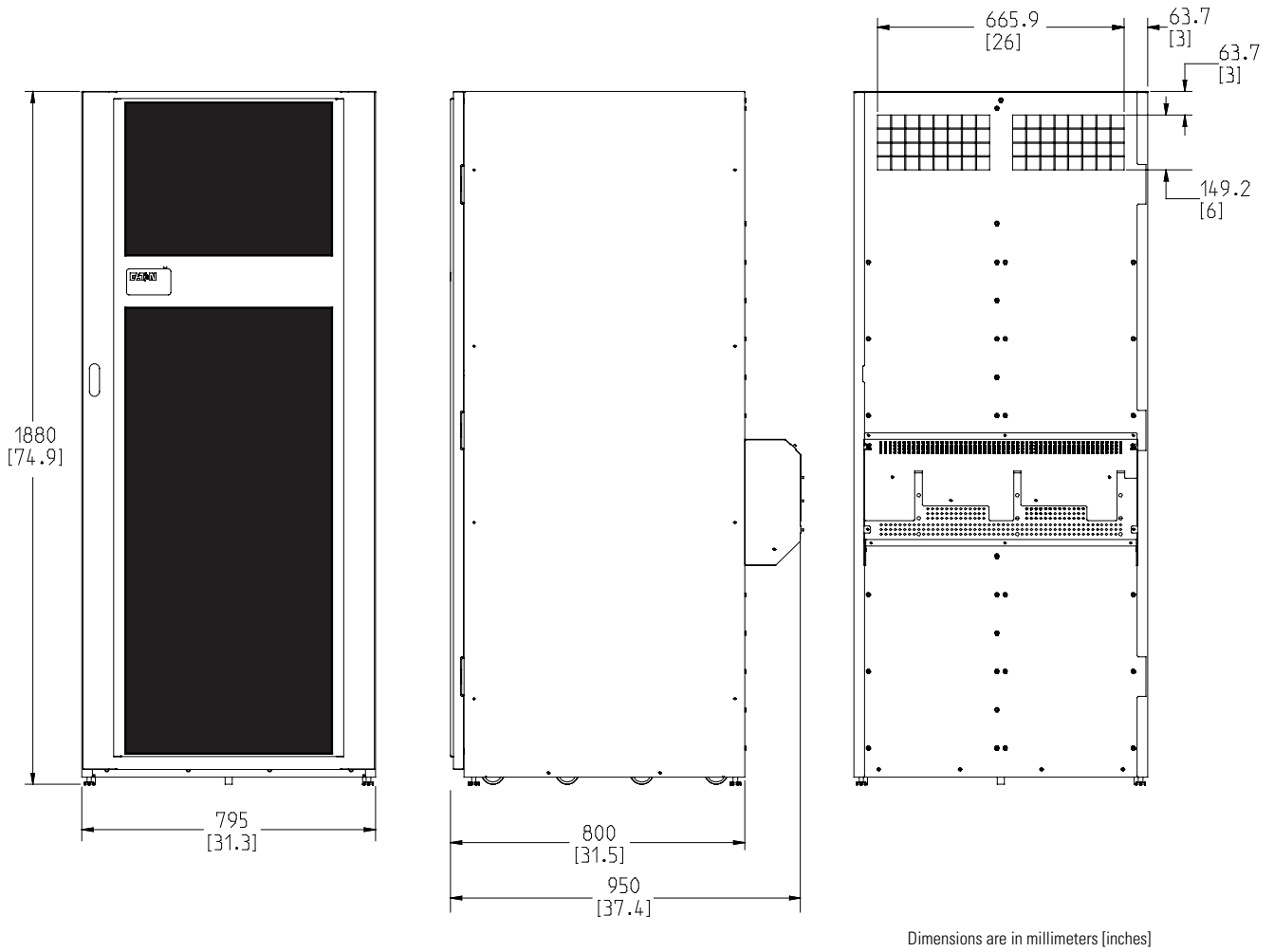
Dimensions are in millimeters [inches]

**Figure 3-2. 93E 30EBC Dimensions (Top and Bottom Views)**



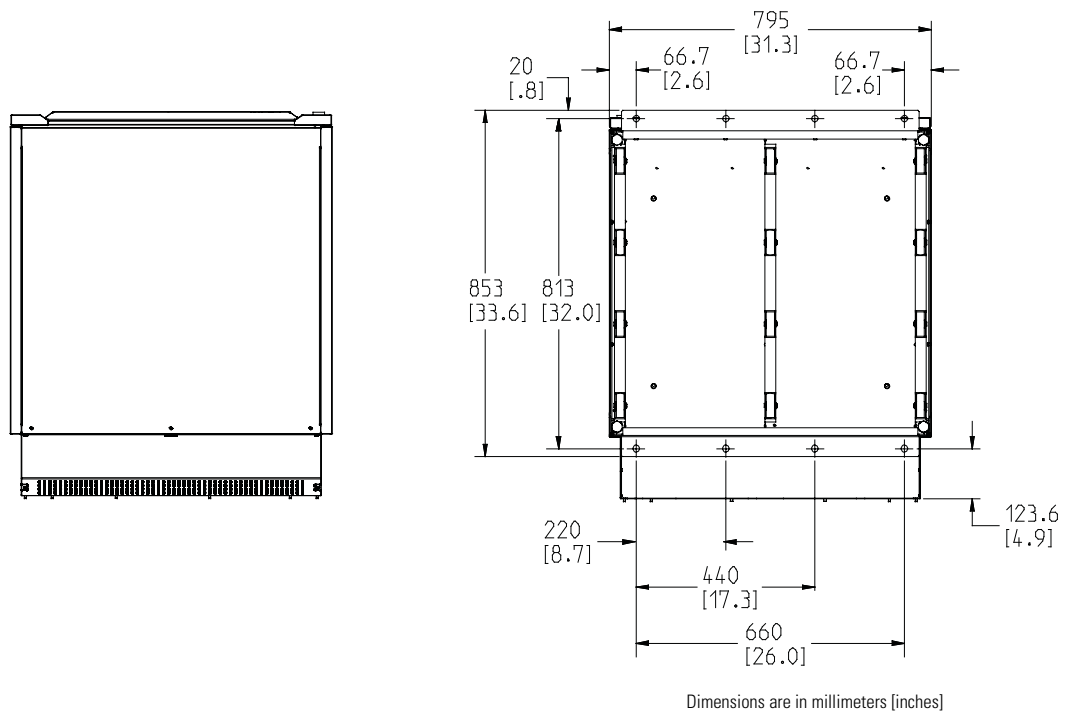
Center of Gravity			
	A	B	C
With 2 strings	504 (20.0)	430 (17.0)	228 (9.0)
With 3 strings	665 (26.2)	430 (17.0)	224 (8.8)

Figure 3-3. 93E 30EBC Center of Gravity



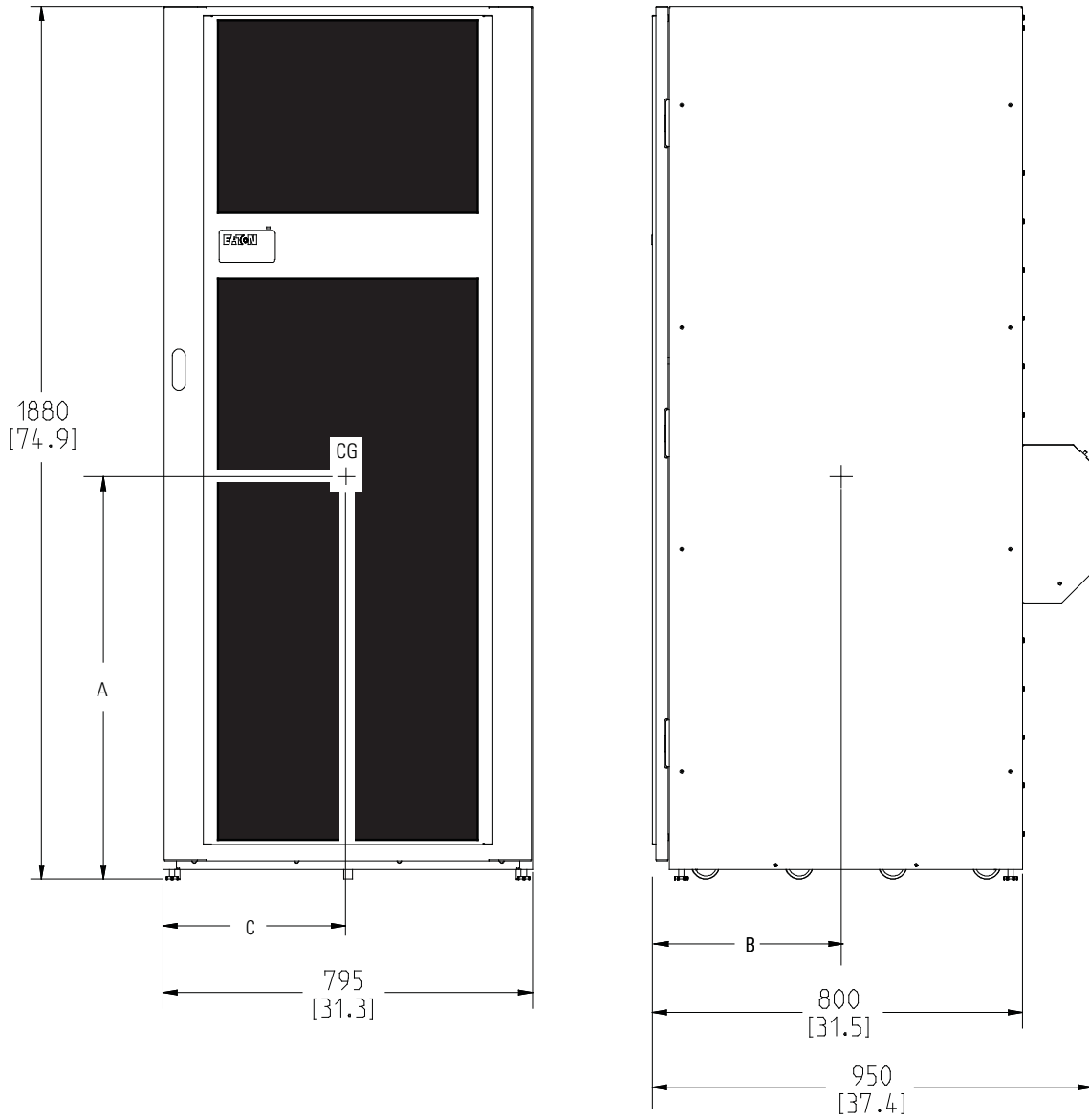
**Figure 3-4. 93E 60EBC Cabinet Dimensions (Front, Right Side, and Rear Views)**





**Figure 3-5. 93E 60EBC Dimensions (Top and Bottom Views)**

# Installation Plan and Unpacking



Dimensions are in millimeters [inches]

### Center of Gravity

	A	B	C
With 4 strings	690 (27.2)	406 (16.0)	392 (15.4)
With 6 strings	865 (34.1)	406 (16.0)	392 (15.4)

**Figure 3-6. 93E 60EBC Center of Gravity**

### 3.2.2 EBC Power Wiring Preparation

Read and understand the following notes while planning and performing the installation:

---

 **WARNING**

---

As a result of the connected loads high leakage current is possible. Connection to earth ground is required for safety and proper product operation. Do not check EBC operation by any action that includes removal of the earth (ground) connection with loads attached.

---

- Refer to national and local electrical codes for acceptable external wiring practices.
- Material and labor for external wiring requirements are to be provided by the customer.
- For external wiring, use 90°C copper wire. Wire sizes listed in Table 3-3 are for copper wiring only. If wire is run in an ambient temperature greater than 30°C, higher temperature wire and/or larger size wire may be necessary. Wire sizes are based on using the specified breakers.
- Wire ampacities are chosen from Table 310-16 of the National Electrical Code® (NEC®). Specification is for copper wire with a 90°C rating.
- The battery wiring used between the battery and the UPS should be a maximum of 20 meters (65 feet) and not allow a voltage drop of more than 1% of nominal DC voltage at rated battery current.
- Refer to NEC Article 250 and local codes for proper grounding practices.
- Battery voltage is computed at 2 volts per cell as defined by Article 480 of the NEC. Rated battery current is computed at 2 volts per cell.
- The battery cabinet frame is not referenced to the DC circuit.
- Each battery cabinet has its own overcurrent protection device.
- External battery cabinets can be used in combination with a UPS containing internal batteries.
- Internal battery strings are to be connected by an authorized Eaton Customer Service Engineer.
- Refer to the appropriate Eaton 93E UPS Installation and Operation manual listed in paragraph 1.7 for UPS cabinet conduit and terminal specifications and locations.
- The term line-up-and-match refers to accessory cabinets that are physically located adjacent to the UPS. The term standalone refers to accessory cabinets that are located separate from the UPS.

For external power wiring requirements, including the minimum AWG size of external wiring, see Table 3-3. Wire sizes listed are for copper wiring only.

**Table 3-3. External Power Wiring Requirements for the Eaton 93E 30EBC and 60EBC**

Model	Number of Cabinets	Terminal	Battery Cabinet to UPS or Next Battery Cabinet	
			Minimum Conductor Size (AWG or kcmil)	Number per Pole
30EBC	1 or 2	Battery (+)	1/0	1
		Battery (–)	1/0	1
		Ground	#6	1 per cabinet
60EBC	1 or 2	Battery (+)	1/0	2
		Battery (–)	1/0	2
		Ground	#6	1 per cabinet

## Installation Plan and Unpacking

The power wiring terminals are pressure terminations, UL and CSA rated at 90°C. See Table 3-4 for external power cable terminations.

Figure 4-7 and Figure 4-8 show the location of the EBC power cable terminals.

**Table 3-4. External Power Cable Terminations for the Eaton 93E 30EBC and 60EBC**

Model	Terminal Function	Terminal	Function	Number and Size of Pressure Termination	Tightening Torque Nm (lb in)	Screw Size and Type
30EBC	DC Input and Output	Battery +	Positive	2 - #14-2/0	5.6 (50)	3/16" Hex
		Battery –	Negative	2 - #14-2/0	5.6 (50)	3/16" Hex
60EBC	DC Input and Output	Battery +	Positive	2 - #6-250 kcmil	31.1 (275)	5/16" Hex
		Battery –	Negative	2 - #6-250 kcmil	31.1 (275)	5/16" Hex
	Customer Ground	Ground	Ground	2 - #14-1/0	5.6 (50)	7/16" Slot

**NOTE** Customer ground, sized in accordance with NEC Table 250.122, can be run in any conduit listed. Refer to the appropriate UPS manual.

External DC input overcurrent protection and disconnect switch for the remote battery location is to be provided by the user. Table 3-5 lists the maximum rating for continuous-duty rated circuit breakers satisfying the criteria for both.

**Table 3-5. Recommended DC Circuit Breaker or Disconnect Ratings**

Model	Input Rating 208V
93E 30EBC	175A
93E 60EBC	350A

### 3.3 Battery Type

The battery types listed in Table 3-6 are supplied in the EBC. When replacing the EBC batteries, only the following type is recommended. Use of any other battery type or mixing battery letter designation and sizes inside Eaton cabinets will damage equipment and void the product warranty. When replacing batteries use the same manufacturer and part number originally supplied with the unit to ensure correct harness fit and terminal landing.


**Table 3-6. Battery Type**

<b>Battery Manufacturer</b>	Eaton Corporation
<b>Battery Model</b>	PWHR12120W3FR
<b>Battery Quantity –93E 30EBC</b>	18 per string up to 3 strings per cabinet Up to a Total of 54
<b>Battery Quantity – 93E 60EBC</b>	18 per string up to 6 strings per cabinet Up to a Total of 108

### 3.4 Inspecting and Unpacking the EBC

The cabinet is shipped bolted to a wooden pallet (30EBC) or a wooden and metal pallet (60EBC) and covered with outer protective packaging material (see Figure 3-7).

---

**NOTE**  Startup and operational checks must be performed by an authorized Eaton Customer Service Engineer, or the warranty terms specified on page W-1 become void. This service is offered as part of the sales contract for the UPS. Contact an Eaton service representative in advance (usually a two-week notice is required) to reserve a preferred startup date.

---



---

**WARNING** 

---

The EBC is heavy (see Table 3-1). If unpacking and unloading instructions are not closely followed, the cabinet may tip and cause serious injury.

---

- Carefully inspect the outer packaging for evidence of damage during transit.
- 

**CAUTION** 


---

Do not install a damaged cabinet. Report any damage to the carrier and contact an Eaton service representative immediately.

---



---

**NOTE**  For the following step, verify that the forklift or pallet jack is rated to handle the weight of the cabinet (see Table 3-1 for cabinet weight).

---

- Use a forklift or pallet jack to move the packaged cabinet to the installation site, or as close as possible, before unpacking. If possible, move the cabinet using the pallet. Insert the forklift or pallet jack forks between the supports on the bottom of the pallet (see Figure 3-3 or Figure 3-6) for the EBC cabinet center of gravity measurements).
- 


**CAUTION** 

---

Do not tilt the UPS cabinets more than 10° from vertical or the cabinets may tip over.

---

- Set the pallet on a firm, level surface, allowing a minimum clearance of 3m (10 ft) on each side for removing the cabinet from the pallet.
  - Remove the protective packaging material from the cabinet and recycle in a responsible manner. Retain the parts kit box packed at the top of the cabinet.
  - Inspect the contents for any evidence of physical damage, and compare each item with the Bill of Lading. If damage has occurred or shortages are evident, contact an Eaton service representative immediately to determine the extent of the damage and its impact on further installation.
- 

**NOTE**  While waiting for installation, protect the unpacked cabinet from moisture, dust, and other harmful contaminants. Failure to store and protect the EBC properly may void your warranty.

---

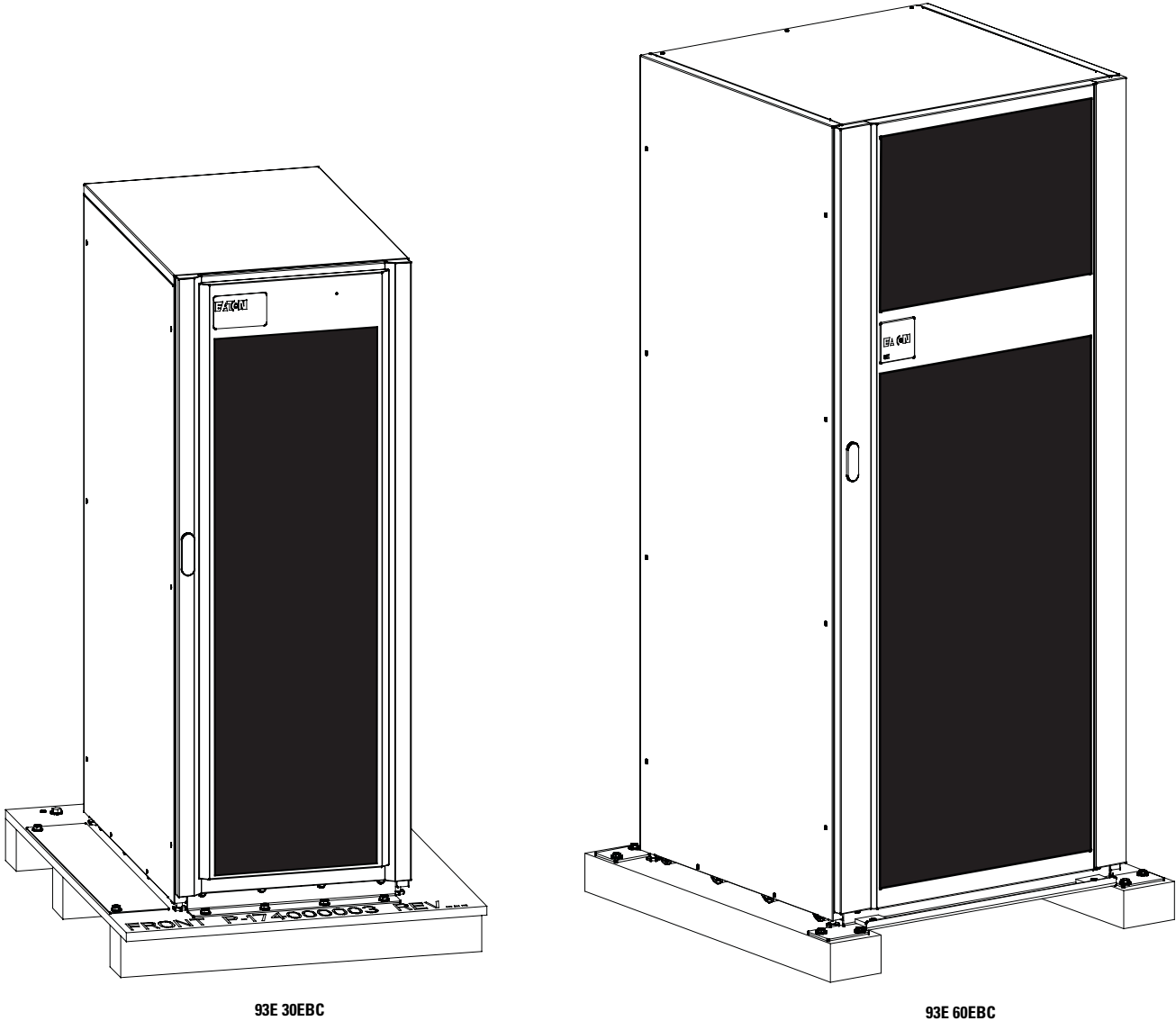
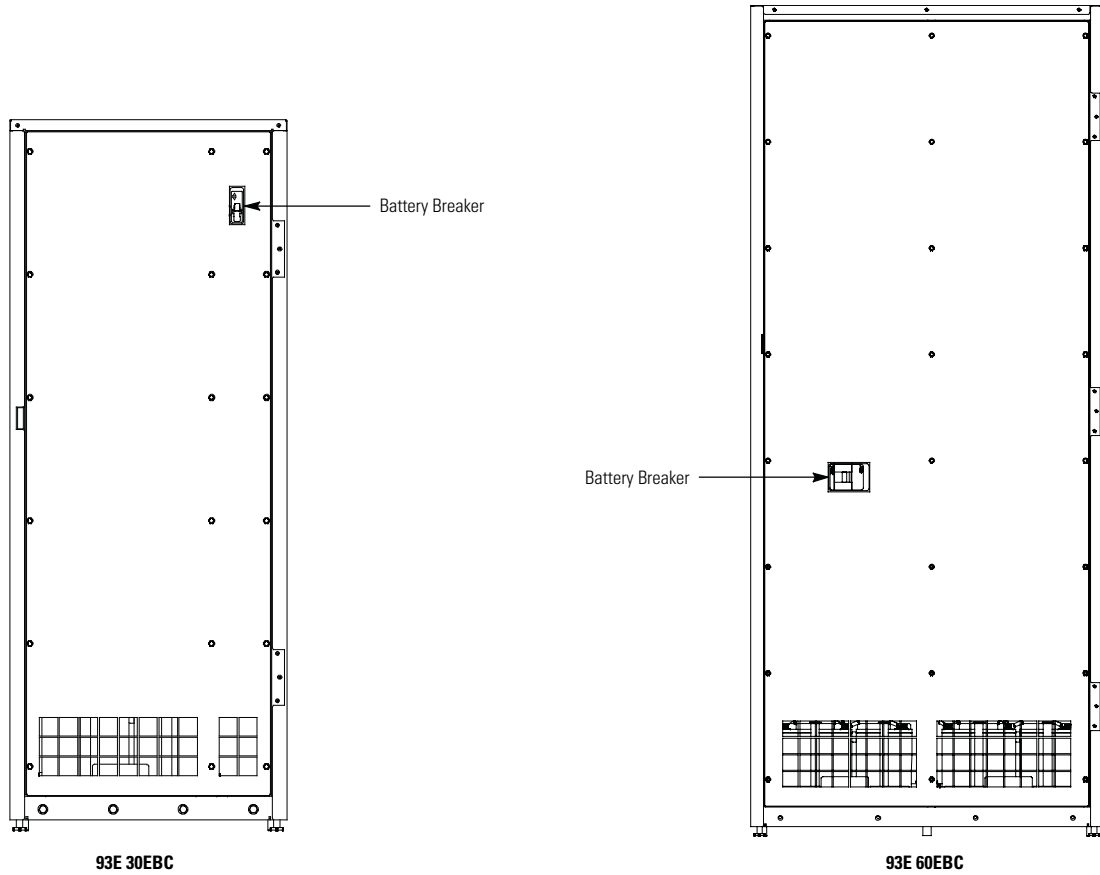


Figure 3-7. Eaton 93E 30EBC and Eaton 93E 60EBC as Shipped on Pallet

### 3.5 Battery Breaker Location

Figure 3-8 shows the location of the battery breakers in the 93E 30EBC and the 93E 60EBC.



**Figure 3-8. Eaton 93E 30EBC and Eaton 93E 60EBC Battery Breaker Locations – Front Views with Doors Removed**

This page intentionally left blank.



## Chapter 4 Installation

### 4.1 Preliminary Installation Information

---

** WARNING**

---

Installation should be performed only by qualified personnel knowledgeable of batteries and the required precautions.

---

Refer to the following while installing the External Battery Cabinet (EBC):

- Chapter 3 for cabinet dimensions, equipment weight, wiring and terminal data, and installation notes.
- Do not tilt the cabinets more than 10° during installation.

### 4.2 Unloading the EBC Cabinet from the Pallet

---

** WARNING**

---

The EBC is heavy (see Table 3-1). If unpacking and unloading instructions are not closely followed, the cabinet may tip and cause serious injury.

---

---

** CAUTION**

---

- Do not tilt cabinet more than 10° from vertical.
  - Lift the cabinets only with a forklift or damage may occur.
- 

**NOTE 1** The EBC uses inline wheels, not swivel casters. When moving the EBC, move the cabinet in straight lines as much as possible, minimizing turns.



**NOTE 2** For the following procedures, verify that the forklift or pallet jack is rated to handle the weight of the cabinet (see Table 3-1 for cabinet weights).

---

#### 4.2.1 Unloading the 30EBC

The EBC is bolted to a wooden pallet supported by wood skids.

---

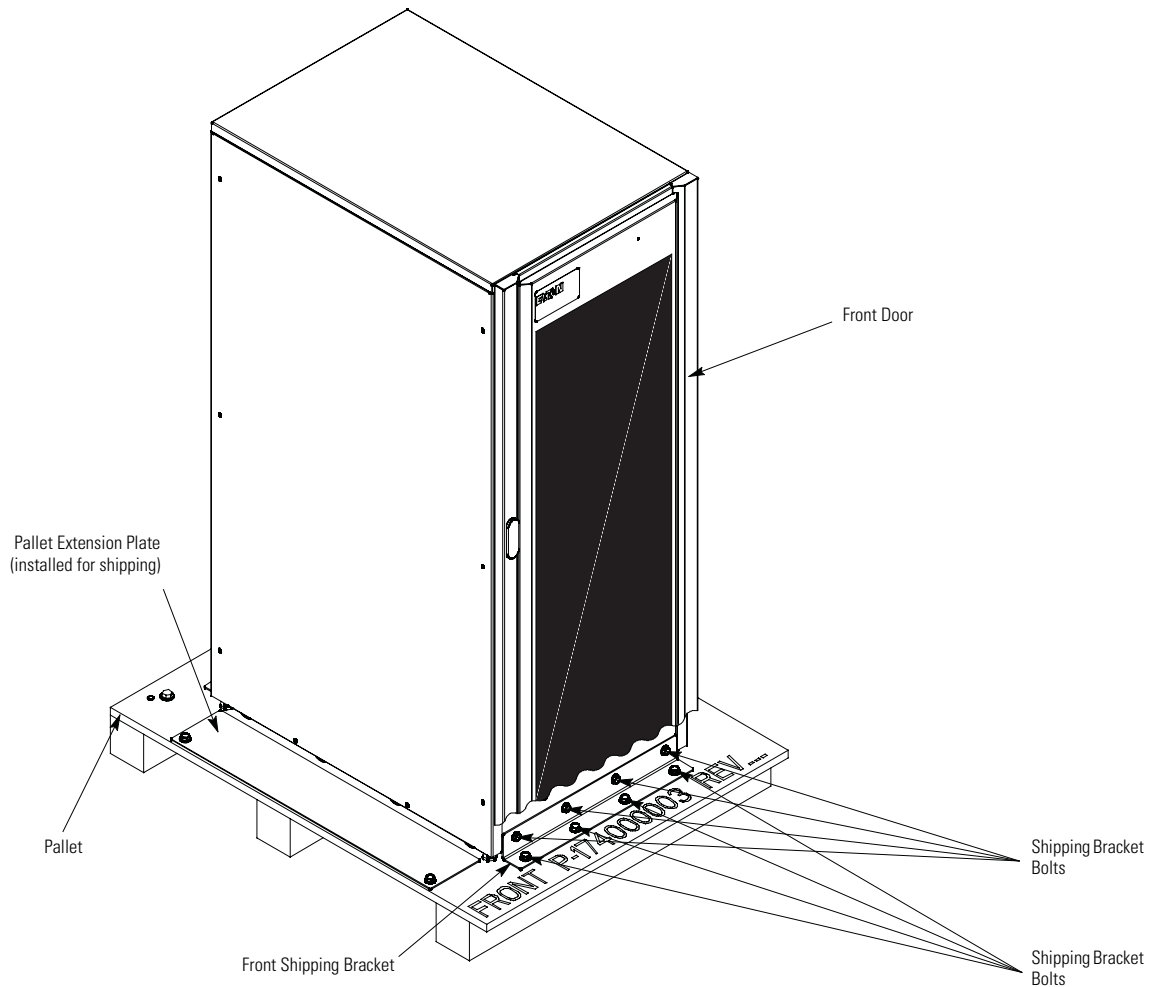
** CAUTION**

---

- Ensure a minimum of 10 feet behind the EBC for unloading. The area behind the EBC must be unobstructed.
  - The unloading floor must be smooth, with no cracks or large seams to prevent a smooth rolloff of the cabinet.
- 

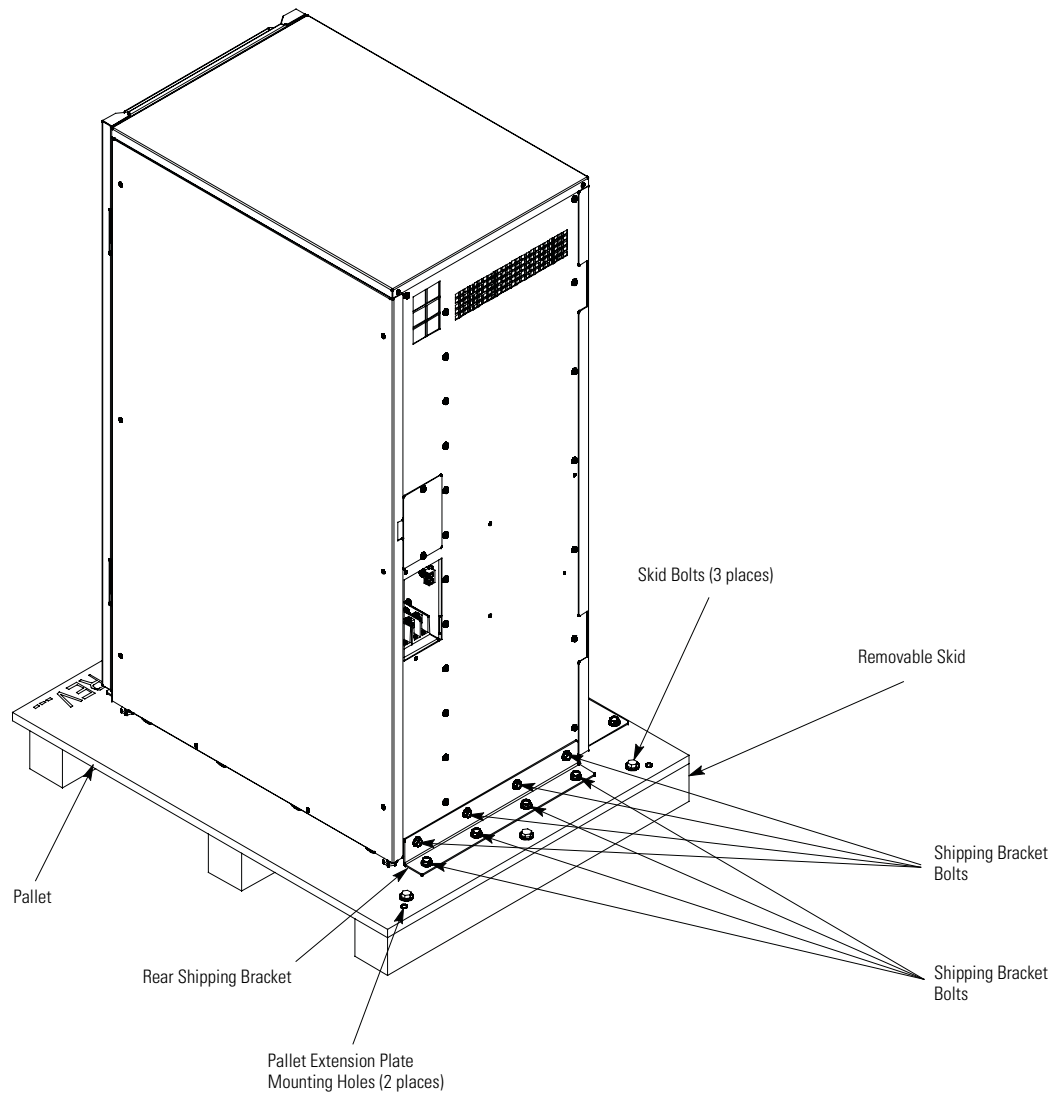
To remove the pallet:

1. If not already accomplished, use a forklift or pallet jack to move the EBC to the installation area, or as close as possible, before unloading from the pallet. Insert the forklift or pallet jack forks between the supports on the bottom of the pallet (see Figure 3-3 for the EBC cabinet center of gravity measurements).
2. Open the front door (see Figure 4-1) by lifting the latch from the bottom and turning to the right (counterclockwise) and swing the door open.
3. If the leveling feet are not fully retracted, turn all four leveling feet until they are retracted into the cabinet.



**Figure 4-1. Removing the Front Shipping Bracket – 93E 30EBC**

4. Remove four bolts securing the front shipping bracket to the cabinet and four bolts securing the bracket to the pallet (see Figure 4-1). Remove the front shipping bracket. If installing the cabinet permanently, retain the shipping bracket and securing hardware for later use.
5. Remove four bolts securing the rear shipping bracket to the cabinet and four bolts securing the bracket to the pallet (see Figure 4-2). Remove the rear shipping bracket. If installing the cabinet permanently, retain the shipping bracket and securing hardware for later use.
6. Close the door and secure the latch before rolling the cabinet from the pallet.
7. Remove three bolts securing the removable skid (see Figure 4-2).
8. Remove two bolts securing the pallet extension plate to the pallet and remove the plate (see Figure 4-1). Retain the plate and bolts for use in Step 9.
9. Install the pallet extension plate onto the rear of the pallet using the retained bolts (see Figure 4-3). Use mounting holes provided in the pallet (see Figure 4-2).
10. Use a forklift or pallet jack between the supports on the bottom of the pallet to lift the pallet by approximately 3 mm (1/8") and remove the skid (see Figure 4-2).



**Figure 4-2. Removing the Rear Shipping Bracket – 93E 30EBC**

**NOTE 1** In the following step the pallet tilts and acts as a ramp once the cabinet is rolled beyond the center of the pallet.



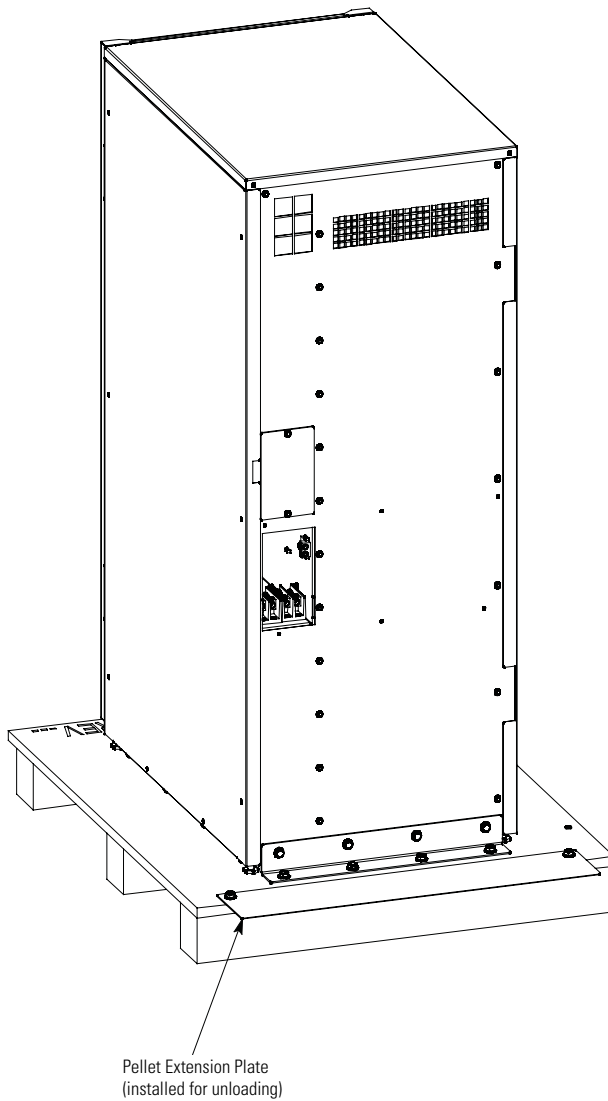
**NOTE 2** The pallet extension may bend when the pallet is tilted, but will continue to provide a smooth transition to the floor.



**WARNING**

Do not stand directly in front of or behind the pallet while unloading the cabinet. If unloading instructions are not closely followed, the cabinet may cause serious injury.

11. Slowly roll the cabinet toward the rear of the pallet. Once the pallet tilts, continue rolling the cabinet down the pallet until the cabinet is clear of the pallet.



**Figure 4-3. Installing the Pellet Extension Plate – 93E 30EBC**

12. Roll the EBC to the final installation location on the right side of the UPS cabinet making sure the doors are flush with each other.
13. If installing the cabinet permanently, retain the shipping brackets and hardware; otherwise, recycle the pallet, and shipping brackets in a responsible manner.



**NOTE**

Use leveling feet only to lock the cabinet in place. Using the leveling feet to raise the cabinet may result in serious injury to personnel or damage to the cabinet.

---

14. Secure the EBC in position by lowering the leveling feet until the cabinet is locked in place.
15. If permanently mounting the EBC, proceed to Step 16; otherwise, continue to Step 18.
16. Using the retained hardware, reinstall the shipping brackets removed in Steps 4 and 5 to the front and rear of the EBC with the angle facing outward (see Figure 4-1 and Figure 4-2).

17. Secure the cabinet to the floor with customer-supplied hardware.
18. If installing a second EBC, repeat Steps 1 through 17; otherwise, proceed to Step 19. Install the second EBC on the right side of the first EBC.
19. Proceed to paragraph 4.3.

#### 4.2.2 Unloading the 60EBC

The EBC is bolted to a pallet consisting of four metal angle supports secured to two wood supports.

To remove the pallet:

1. If not already accomplished, use a forklift or pallet jack to move the EBC to the installation area, or as close as possible, before unloading from the pallet. Insert the forklift or pallet jack forks between the supports on the bottom of the pallet (see Figure 3-6 for the EBC cabinet center of gravity measurements).
2. Open the front door (see Figure 4-4) by lifting the latch from the bottom and turning to the right (counterclockwise) and swing the door open.
3. Locate the four 1/2" jacking bolts from the parts kit and install them in the threaded holes in the front and rear supports as shown in Figure 4-4. Place a floor protector from the parts kit underneath each jacking bolt, and screw the bolts down against them.

The floor protectors protect the floor from being marred by the jacking bolts.

4. Loosen, but do not remove, the skid mounting bolts holding the pallet skids to the front and rear supports (see Figure 4-4).



#### WARNING

---

RISK OF INSTABILITY. Turning the jacking bolts unevenly may cause the cabinet to become unbalanced. To prevent tipping the cabinet, raise and lower the jacking bolts evenly.

---



#### CAUTION

---

CABINET MAY TIP. Raise the EBC no more than 3 mm (1/8") above the floor (just enough to allow the removal of the pallet skids).

---

5. Turn each jacking bolt consecutively, two full turns, until the pallet skids clear the floor by approximately 3 mm (1/8").
6. Remove the hardware loosened in Step 4. Pull the two pallet skids out from under the front and rear supports. Recycle the pallet skids and hardware in a responsible manner.



#### CAUTION

---

CABINET MAY FALL. Do not loosen the hardware attaching the front supports to the cabinet base. The cabinet must be lowered by the jacking bolts before the supports can be removed.

---

7. Carefully and evenly **lower the cabinet by turning each jacking bolt consecutively two full turns (maximum)** until the casters contact the floor and the cabinet is no longer supported by the jacking bolts.
8. After the EBC is resting on the floor, remove the jacking bolts and floor protectors. Recycle them in a responsible manner.
9. Remove the cabinet mounting bolts holding the front and rear supports to the cabinet base (see Figure 4-4).

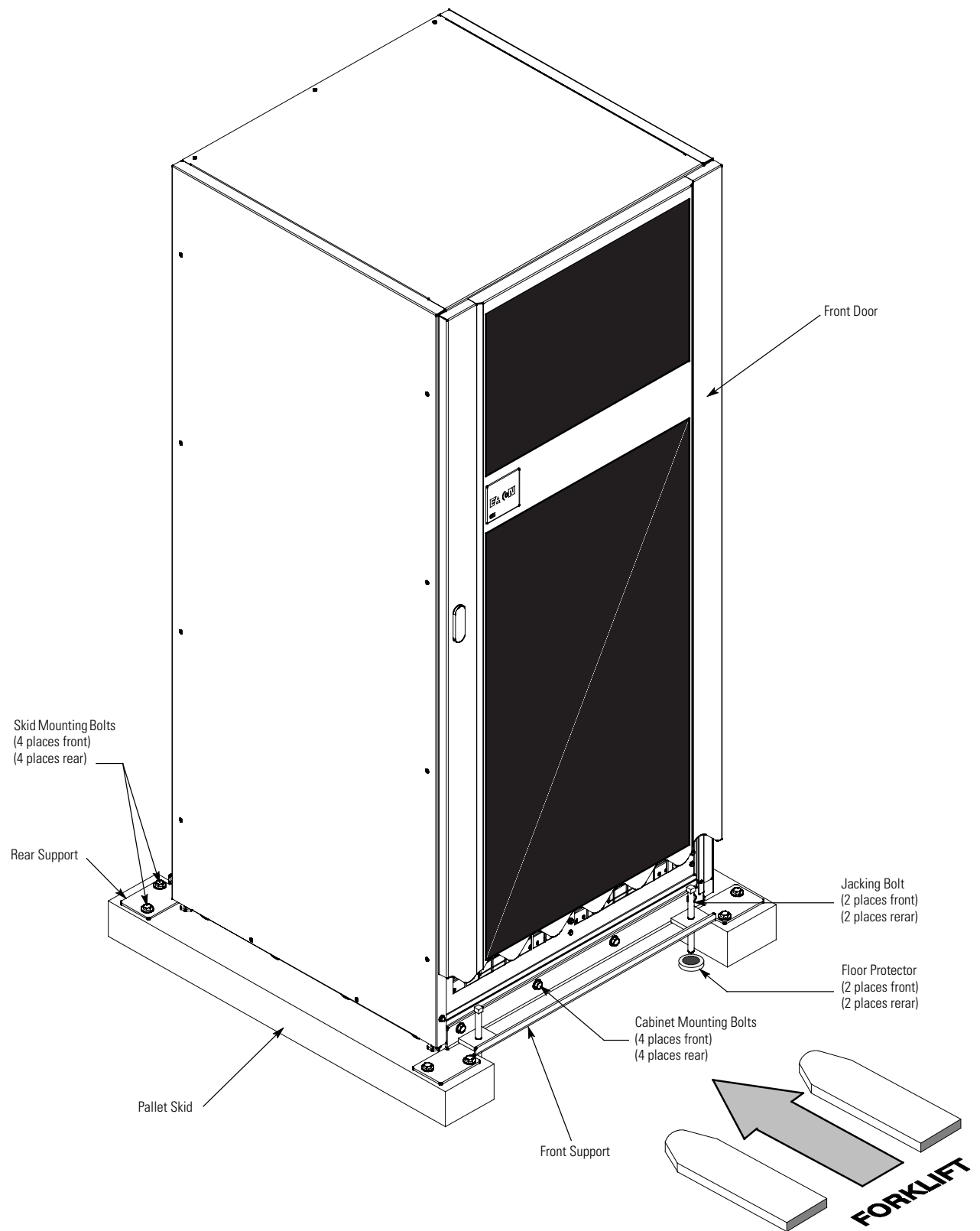
10. If installing the cabinet permanently, retain the cabinet mounting bolts; otherwise, recycle the bolts along with the support brackets in a responsible manner.
11. Close the door and secure the latch.
12. If the leveling feet are not retracted, turn all four leveling feet until they are retracted as far into the cabinet as possible.
13. Roll the EBC to the final installation location on the right side of the UPS cabinet making sure the doors are flush with each other.

**NOTE**

Use leveling feet only to lock the cabinet in place. Using the leveling feet to raise the cabinet may result in serious injury to personnel or damage to the cabinet.

---

14. Secure the EBC in position by lowering the leveling feet until the cabinet is locked in place.
15. If permanently mounting the EBC, proceed to Step 16; otherwise, continue to Step 19.
16. Locate the two floor mounting brackets from the parts kit.
17. Using the retained cabinet mounting bolts, install the floor mounting brackets to the front and rear of the EBC with the angle facing outward.
18. Secure the cabinet to the floor with customer-supplied hardware.
19. If installing a second EBC, repeat Steps 1 through 18; otherwise, proceed to Step 20. Install the second EBC on the right side of the first EBC.
20. Proceed to paragraph 4.3.



**Figure 4-4. Removing the Pallet Skids and Supports – 93E 60EBC**

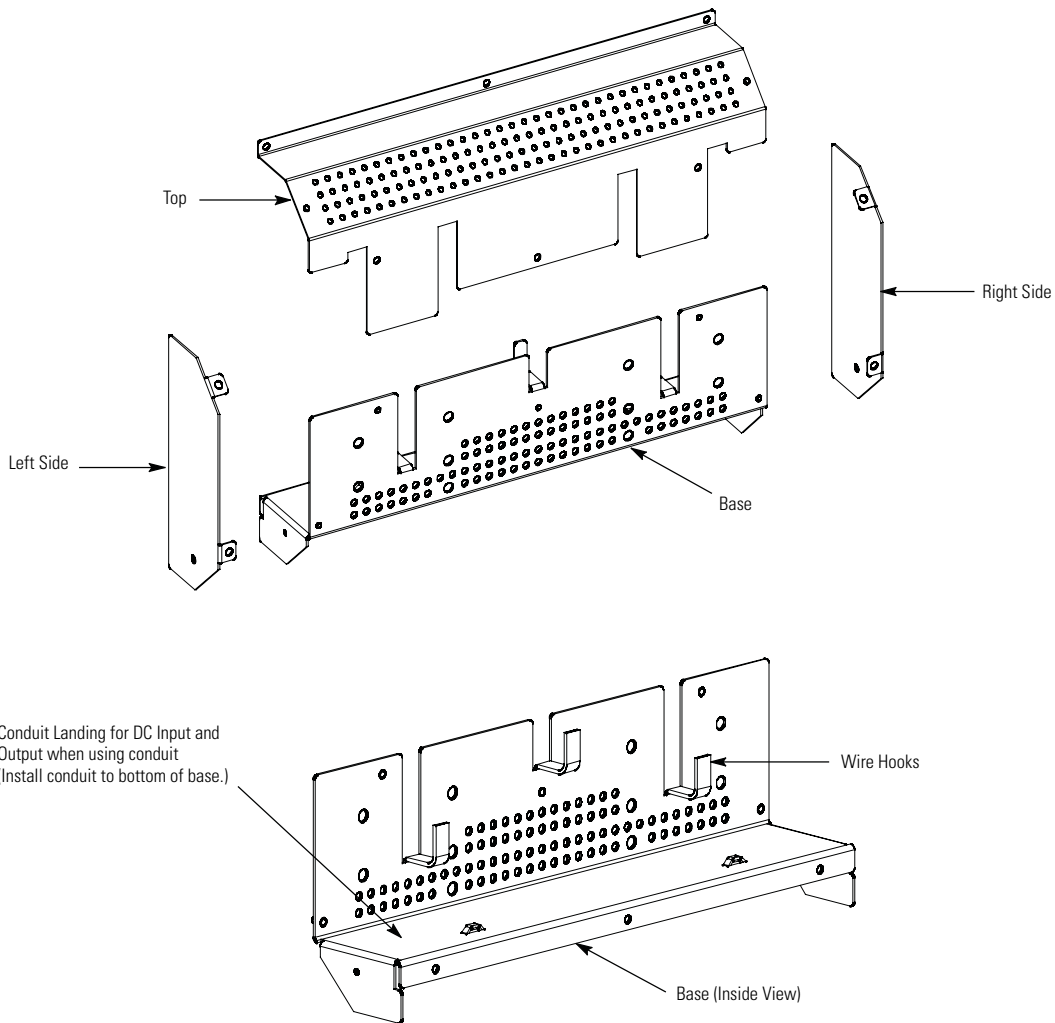
### 4.3 Installing Power Terminal Cover Base



**NOTE** Wiring can be installed using conduit between cabinets or by routing wiring through the power terminal cover base wiring channels.

To install the Power Terminal Cover Base:

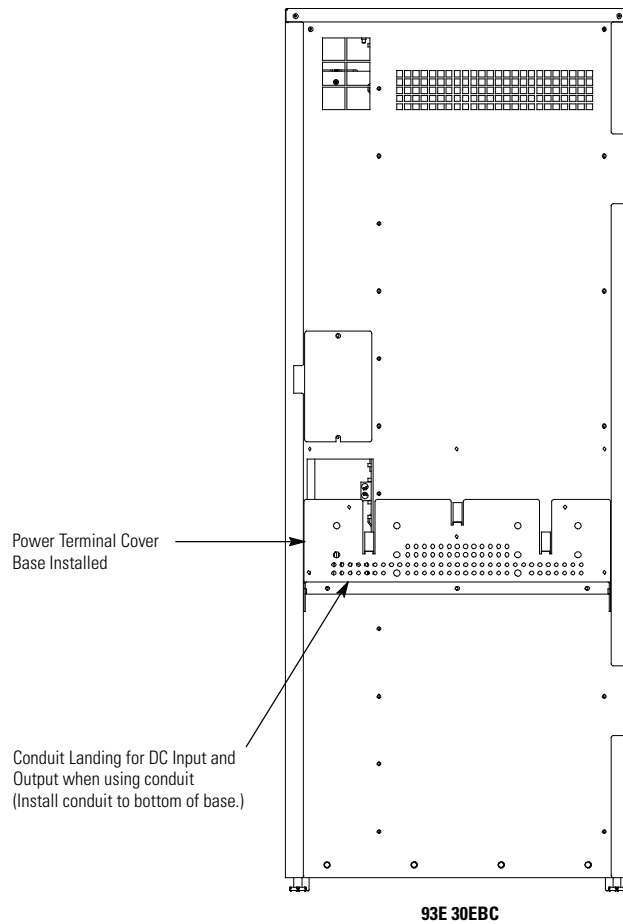
1. Locate the terminal cover base (see Figure 4-5) from the parts kit.
2. If installing wiring using conduit, proceed to Step 3; otherwise, proceed to Step 4.
3. Punch or drill holes in the bottom of the power terminal cover base (see Figure 4-5 and Figure 4-6) for the DC output conduit and if a second EBC is being installed, for the DC input conduit.
4. Using the hardware provided, install the terminal cover base to the back panel of the EBC using the existing cabinet screw holes (see Figure 4-6).
5. Proceed to paragraph 4.4.



**NOTE** Do not install the Power Terminal Cover Left and/or Right Side covers if wiring adjacent cabinets using the power terminal base wiring channel.

**Figure 4-5. EBC Power Terminal Cover Parts**





**NOTE** The 93E 30EBC is shown. However, the 93E 60EBC installation is the identical.

**Figure 4-6. EBC Power Terminal Cover Base Installation and Conduit Wire Entry Location**

#### 4.4 Installing EBC External Power Wiring



**NOTE** Wiring can be installed using conduit between cabinets or by routing wiring through the power terminal cover base wiring channels.

To install wiring to connections:

1. If installing wiring using conduit, proceed to Step 2; if using the power terminal cover base channels, proceed to Step 16.
2. Punch or drill holes in the bottom of the power terminal cover base on the UPS cabinet for the DC input conduit. Refer to the applicable Eaton 93E UPS Installation and Operation manual listed in paragraph 1.7 for UPS cabinet conduit landing location.
3. Install conduit between the UPS cabinet and the EBC. If installing a second EBC, install conduit between the first and second EBCs.
4. Route the battery cables (positive, negative, and ground) through the conduit on the back of EBC 1 to the UPS DC and ground terminal blocks on EBC 1. See Figure 4-7 or Figure 4-9 for wiring access information and terminal locations. See paragraph 3.2.2, Table 3-3, and Table 3-4 for wiring and termination requirements.

---

 **WARNING**


---

Verify polarity of connections. Risk of personal injury and damage to equipment from arc flash if connections are reversed.

---

5. Connect the positive and negative power wiring to the UPS DC (+) and UPS DC (-) terminals on EBC 1. Connect the ground wiring to the ground terminal on EBC 1. See Figure 4-8 or Figure 4-10.
6. Route the other end of the battery cables (positive, negative, and ground) to the UPS cabinet external battery input and ground terminals. Refer to the applicable Eaton 93E UPS Installation and Operation manual listed in paragraph 1.7 for UPS cabinet terminal locations and termination requirements.
7. Connect the positive, negative, and ground power wiring to the UPS cabinet external battery input and ground terminals. Refer to the applicable Eaton 93E UPS Installation and Operation manual listed in paragraph 1.7 for UPS cabinet termination requirements.
8. If installing a second EBC, proceed to Step 9; otherwise, proceed to Step 13.
9. Route the battery cables (positive, negative, and ground) through the conduit on the back of EBC 2 to the UPS DC and ground terminal blocks on EBC 2. See Figure 4-7 or Figure 4-9 for wiring access information and terminal locations. See paragraph 3.2.2, Table 3-3, and Table 3-4 for wiring and termination requirements.
10. Connect the positive and negative power wiring to the UPS DC (+) and UPS DC (-) terminals on EBC 2. Connect the ground wiring to the ground terminal on EBC 2. See Figure 4-8 or Figure 4-10.
11. Route the other end of the battery cables (positive, negative, and ground) to the DC IN and ground terminal blocks on the EBC 1. See Figure 4-7 or Figure 4-9 for wiring access information and terminal locations. See paragraph 3.2.2, Table 3-3, and Table 3-4 for wiring and termination requirements.
12. Connect the positive and negative power wiring to the DC IN (+) and DC IN (-) terminals on EBC 1. Connect the ground wiring to the ground terminal on EBC 1. See Figure 4-8 or Figure 4-10.
13. Install the power terminal cover top using the provided hardware (see Figure 4-12).
14. Install the power terminal cover right and left sides using the provided hardware (see Figure 4-12).
15. Proceed to Step 31.
16. Route the battery cables (positive, negative, and ground) to the EBC 1 UPS DC and ground terminal blocks. See Figure 4-7 or Figure 4-9 for wiring access information and terminal locations. See paragraph 3.2.2, Table 3-3, and Table 3-4 for wiring and termination requirements.
17. Connect the positive and negative power wiring to the UPS DC (+) and UPS DC (-) terminals on EBC 1. Connect the ground wiring to the ground terminal on EBC 1. See Figure 4-8 or Figure 4-10.

---

 **NOTE** Do not tie wrap the DC battery cables to the AC input or output cables in the power terminal cover base wiring channel. Place the DC battery cables at the bottom of the channel.

---

18. Route the other end of the battery cables (positive, negative, and ground) through the EBC 1 and UPS power terminal cover base wiring channels (see Figure 4-11) to the UPS cabinet external battery input and ground terminals. Refer to the applicable Eaton 93E UPS Installation and Operation manual listed in paragraph 1.7 for UPS cabinet terminal locations and termination requirements.
19. Connect the positive, negative, and ground power wiring to the UPS cabinet external battery input and ground terminals. Refer to the applicable Eaton 93E UPS Installation and Operation manual listed in paragraph 1.7 for UPS cabinet termination requirements.
20. If installing a second EBC, proceed to Step 21; otherwise, proceed to Step 26.

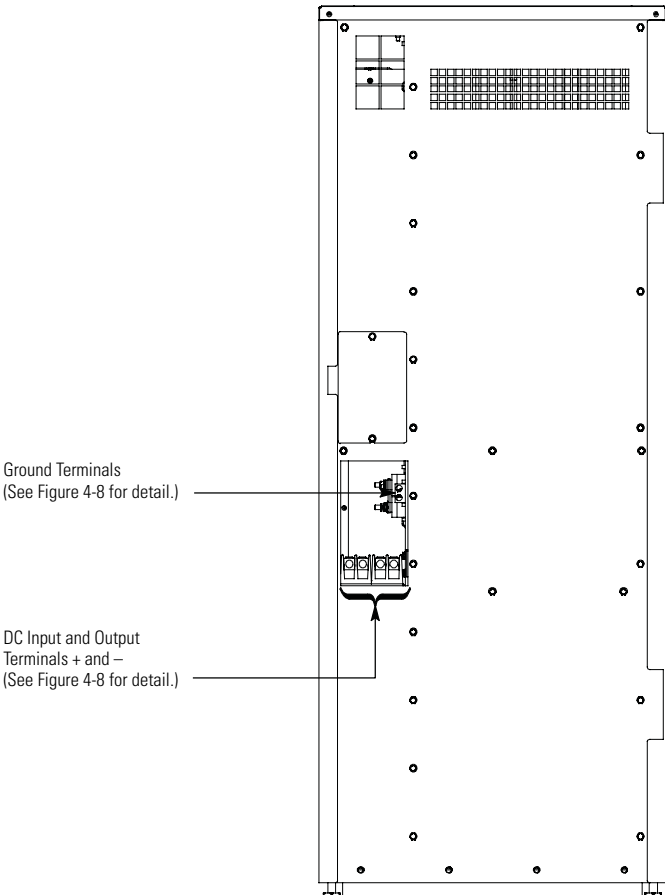
21. Route the battery cables (positive, negative, and ground) through the EBC 2 power terminal cover base wiring channel (see Figure 4-11) to the UPS DC and ground terminal blocks on EBC 2. See Figure 4-7 or Figure 4-9 for wiring access information and terminal locations. See paragraph 3.2.2, Table 3-3, and Table 3-4 for wiring and termination requirements.
22. Connect the positive and negative power wiring to the UPS DC (+) and UPS DC (-) terminals on EBC 2. Connect the ground wiring to the ground terminal on EBC 2. See Figure 4-8 or Figure 4-10.
23. Route the other end of the battery cables (positive, negative, and ground) through the EBC 1 power terminal cover base wiring channel (see Figure 4-11) to the DC IN and ground terminal blocks on EBC 1. See Figure 4-7 or Figure 4-9 for wiring access information and terminal locations. See paragraph 3.2.2, Table 3-3, and Table 3-4 for wiring and termination requirements.
24. Connect the positive and negative power wiring to the DC IN (+) and DC IN (-) terminals on EBC 1. Connect the ground wiring to the ground terminal on EBC 1. See Figure 4-8 or Figure 4-10.
25. Secure the DC battery cables to the bottom of the power terminal cover base using wire ties after all electrical connections have been completed.
26. Install the power terminal cover tops using the provided hardware (see Figure 4-13).
27. Install the EBC left side power terminal cover and the UPS right side power terminal cover using the provided hardware (see Figure 4-13).
28. Install the splice cover using the provided hardware (see Figure 4-13).
29. Proceed to Step 31.
30. Install the right and left side power terminal covers using the provided hardware (see Figure 4-12).

**NOTE**

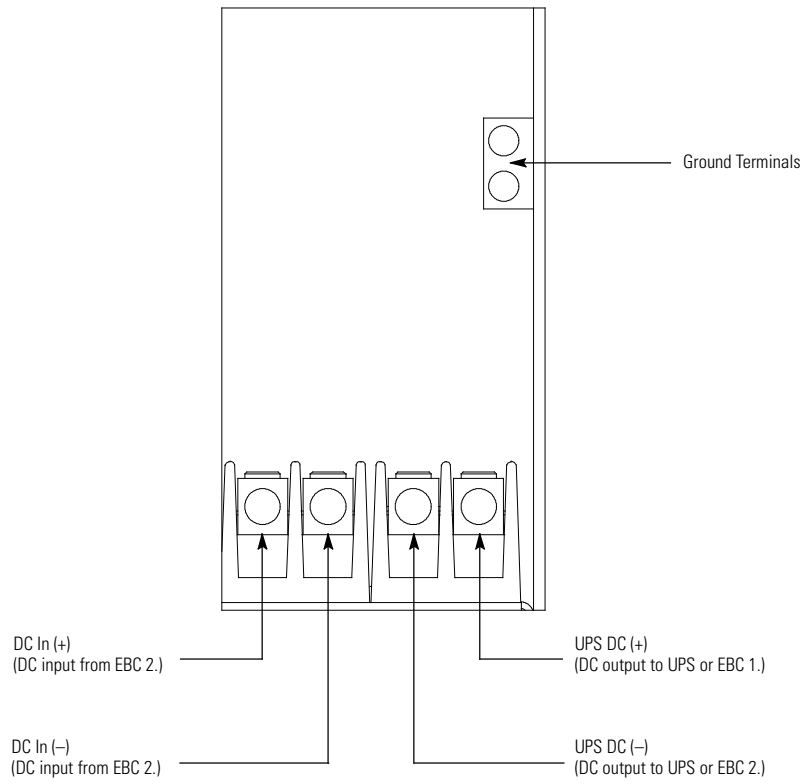
Internal battery strings are to be connected by an authorized Eaton Customer Service Engineer at system startup.

---

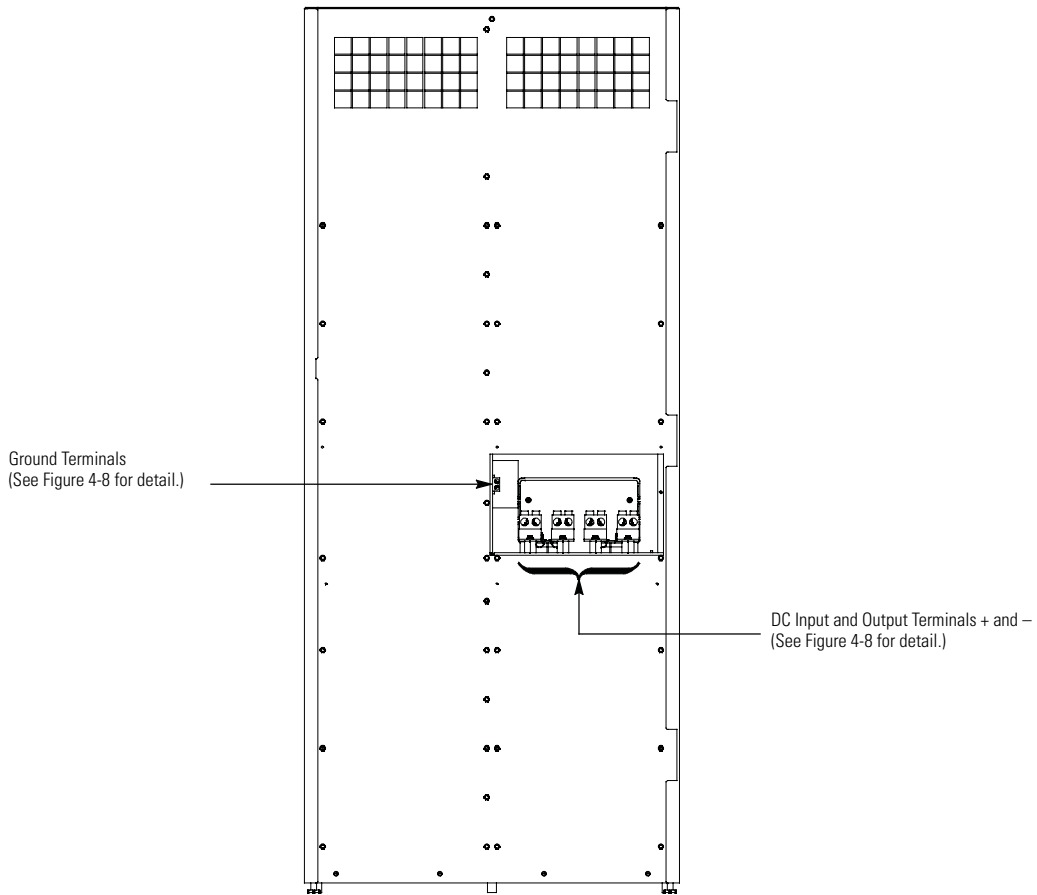
31. Once the battery cabinets are installed and wired, return to the applicable Eaton 93E UPS Installation and Operation manual listed in paragraph 1.7 to complete the UPS wiring.



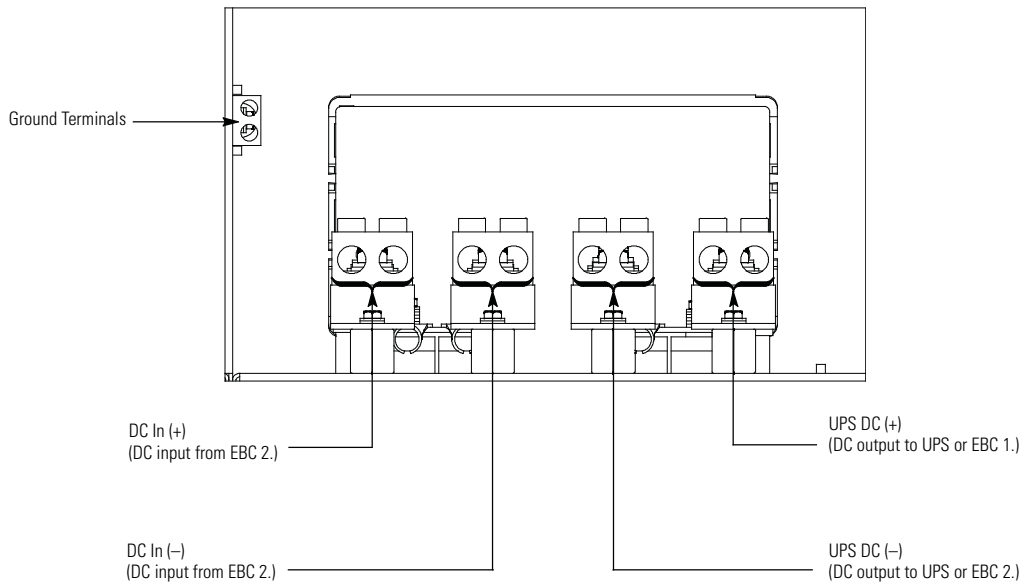
**Figure 4-7. DC Power Terminal Locations – 93E 30EBC**



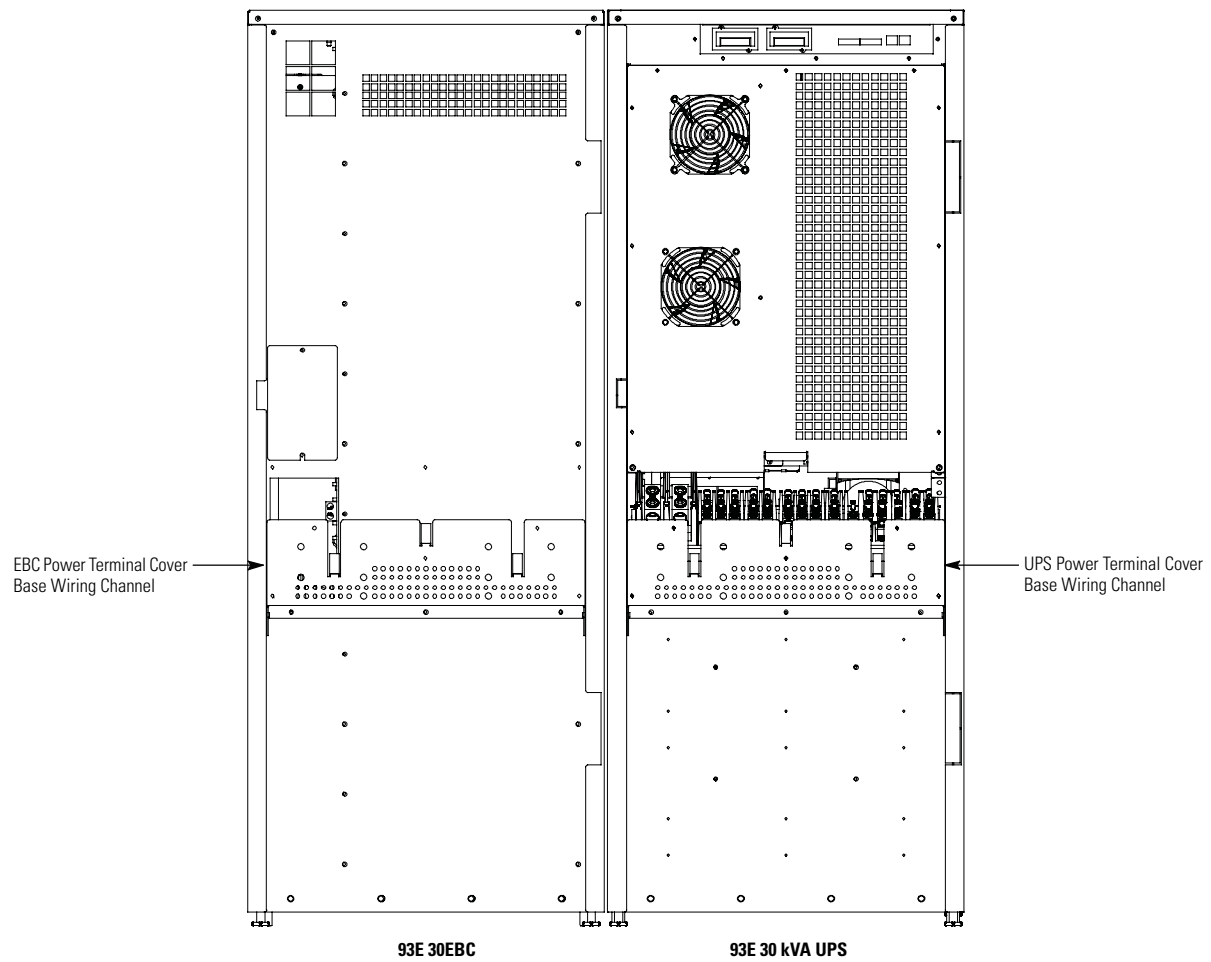
**Figure 4-8. DC Power Terminal Detail – 93E 30EBC**



**Figure 4-9. DC Power Terminal Locations – 93E 60EBC**

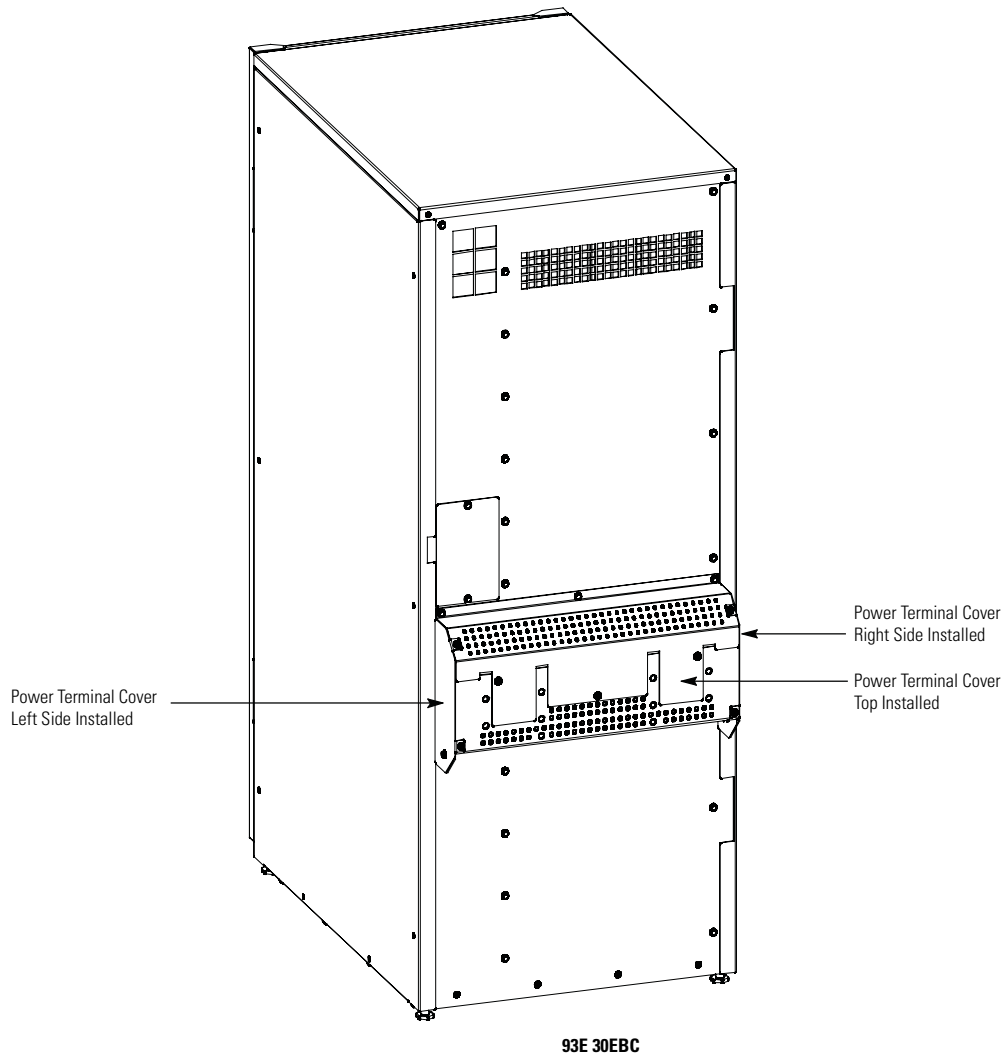


**Figure 4-10. DC Power Terminal Detail – 93E 60EBC**



**NOTE** The 93E 30EBC and 93E 30 kVA UPS are shown. However, the 93E 60EBC and 93E 60 kVA UPS installation is the identical.

**Figure 4-11. EBC and UPS Power Terminal Cover Base Wiring Channel**

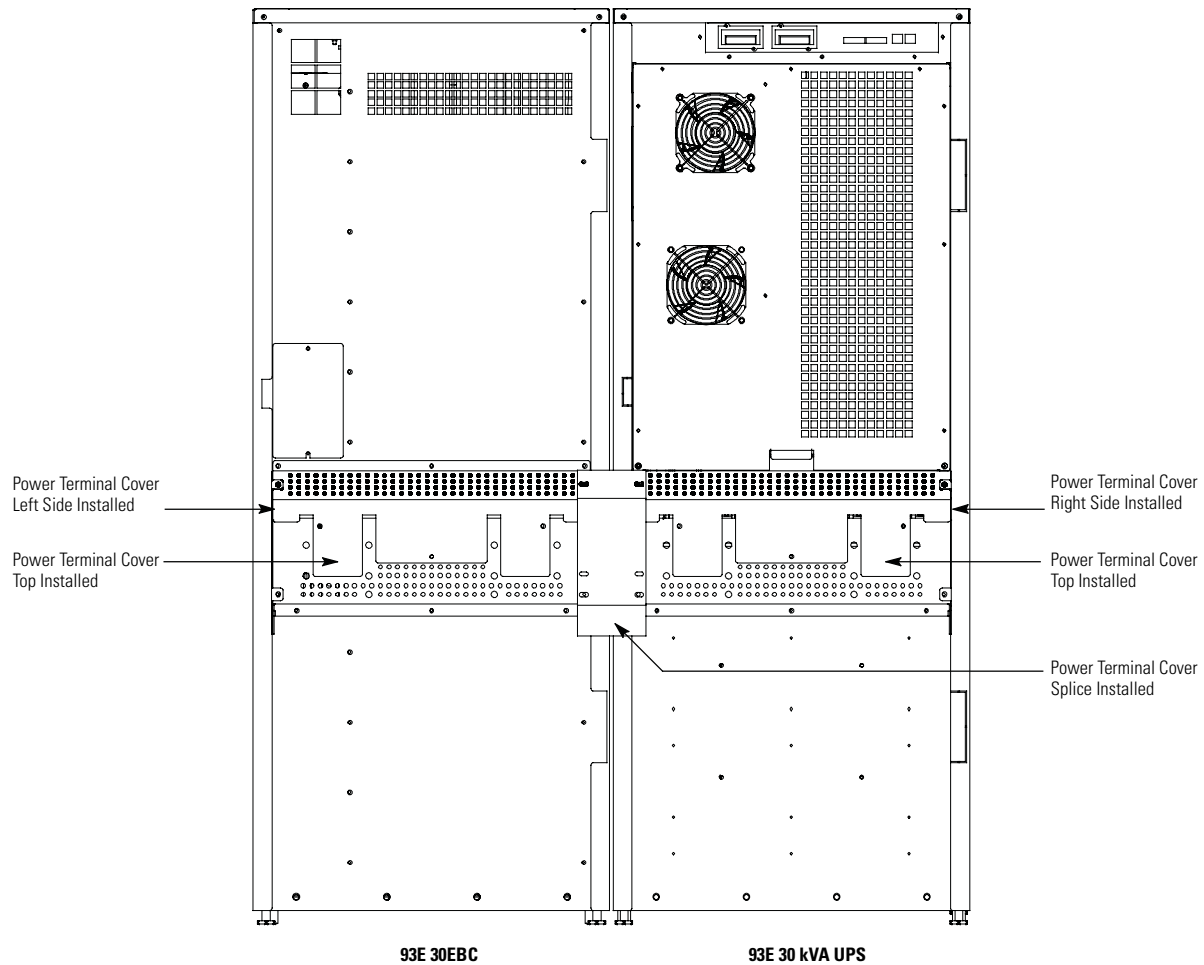


**NOTE 1** The 93E 30EBC is shown. However, the 93E 60EBC installation is identical.

**NOTE 2** Do not install the Power Terminal Cover Left and/or Right Side covers if wiring adjacent cabinets using the power terminal base wiring channel.

**Figure 4-12. EBC Power Terminal Cover Installation**





**NOTE 1** The 93E 30EBC and 93E 30 kVA UPS is shown. However, the 93E 60EBC and 93E 60 kVA UPS installation is identical.

**NOTE 2** Do not install the Power Terminal Cover Left and/or Right Side covers if wiring adjacent cabinets using the power terminal base wiring channel.

**Figure 4-13. EBC Power Terminal Cover Splice Installation**

## 4.5 Initial Startup

Startup and operational checks must be performed by an authorized Eaton Customer Service Engineer, or the warranty terms specified on page W-1 become void. This service is offered as part of the sales contract for the UPS. Contact an Eaton service representative in advance (usually a two-week notice is required) to reserve a preferred startup date.

## 4.6 Completing the Installation Checklist

The final step in installing the EBC is completing the following Installation Checklist. This checklist ensures that you have completely installed all hardware, cables, and other equipment. Complete all items listed on the checklist to ensure a smooth installation. Make a copy of the Installation Checklist before filling it out, and retain the original.

After the installation is complete, an Eaton Customer Service Engineer must verify the operation of the UPS system and commission it to support the critical load. The service representative cannot perform any installation tasks other than verifying software and operating setup parameters. Service personnel may request a copy of the completed Installation Checklist to verify all applicable equipment installations have been completed.



### NOTE

The Installation Checklist MUST be completed prior to starting the UPS system for the first time.

---

## Installation Checklist

- All packing materials and restraints have been removed from each cabinet.
- The EBC is installed on a level floor suitable for computer or electronic equipment.
- The EBC is placed in its installed location
- All conduits and cables are properly routed between the EBC and the UPS.
- All power cables are properly sized and terminated.
- A ground conductor is properly installed.
- All terminal cover plates are installed.
- Air conditioning equipment is installed and operating correctly.
- The area around the UPS system is clean and dust-free.
- Adequate workspace exists around the EBC and other cabinets.
- Adequate lighting is provided around all EBC and UPS equipment.
- A 120 Vac service outlet is located within 7.5 meters (25 feet) of the EBC and UPS equipment.
- Startup and operational checks are performed by an authorized Eaton Customer Service Engineer.

**Notes**

---

---

---

---

---

---

---

---

---

---

---

---

---

---

---

---

---

---

---

---

---

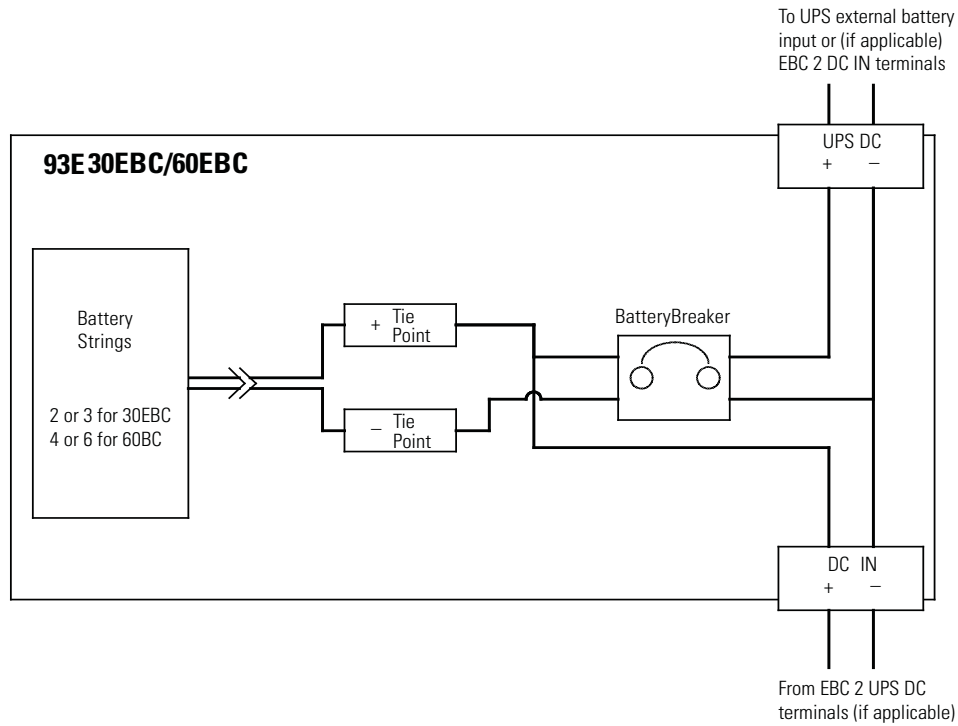
---

This page intentionally left blank.

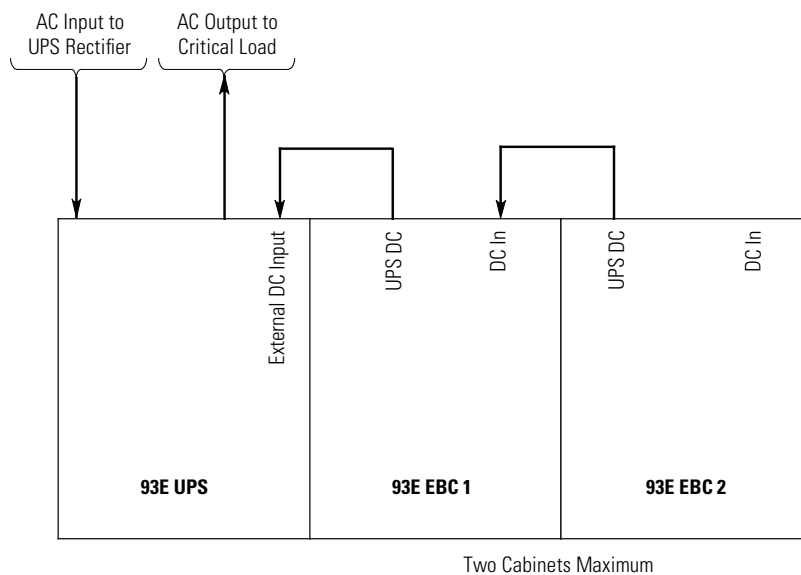
## Chapter 5 Onelines and Schematics

### 5.1 Onelines

Figure 5-1 and Figure 5-2 show the simplified internal structure of the battery cabinet and a simplified UPS and EBC intercabinet connection diagram.



**Figure 5-1. EBC Internal Oneline**



**Figure 5-2. EBC Intercabinet Interconnection Online**

## 5.2 Schematics

Figure 5-3 and Figure 5-4 show the 93E 30 EBC and 93E 60 EBC schematics.

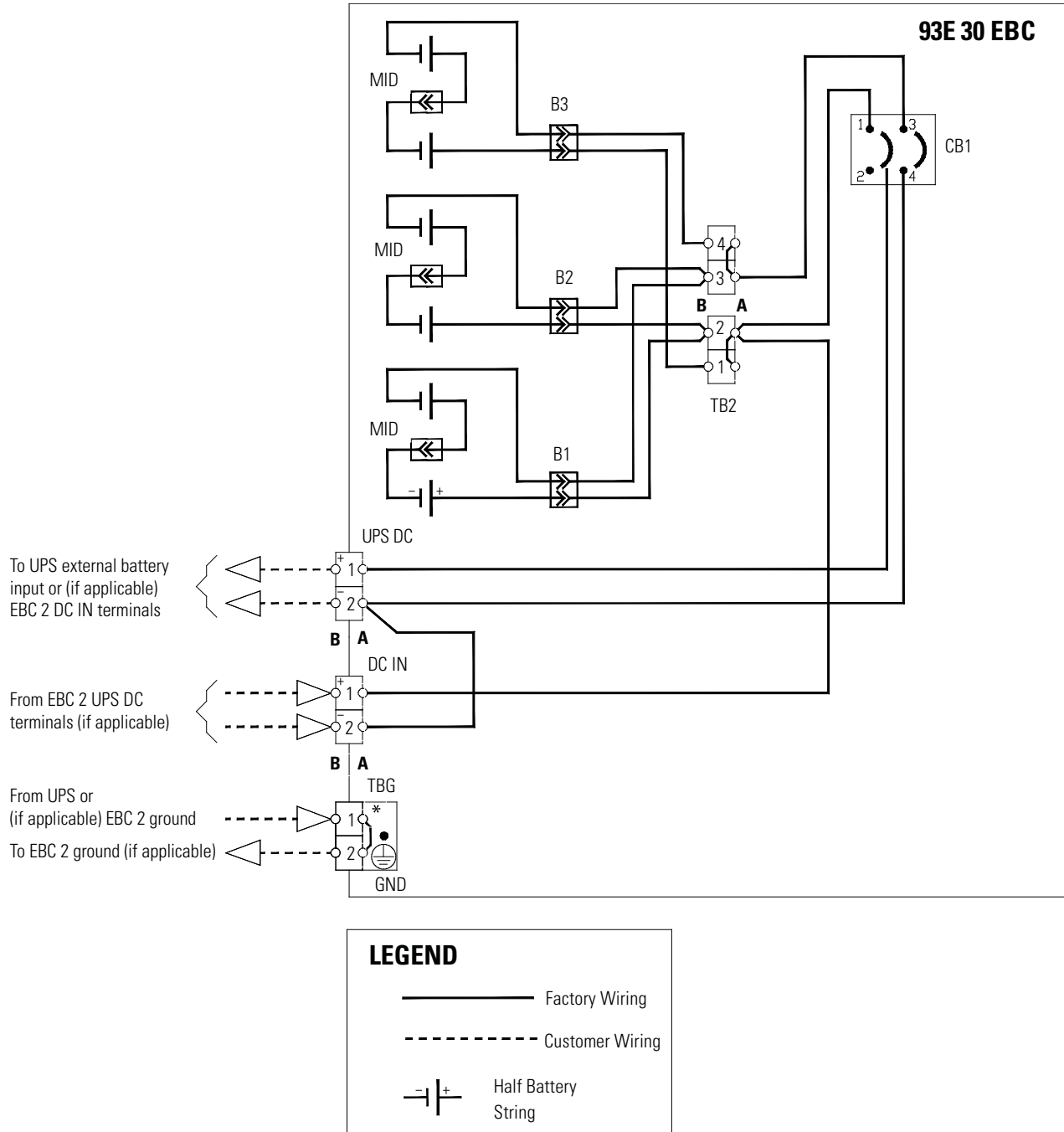


Figure 5-3. 93E 30 EBC Schematic

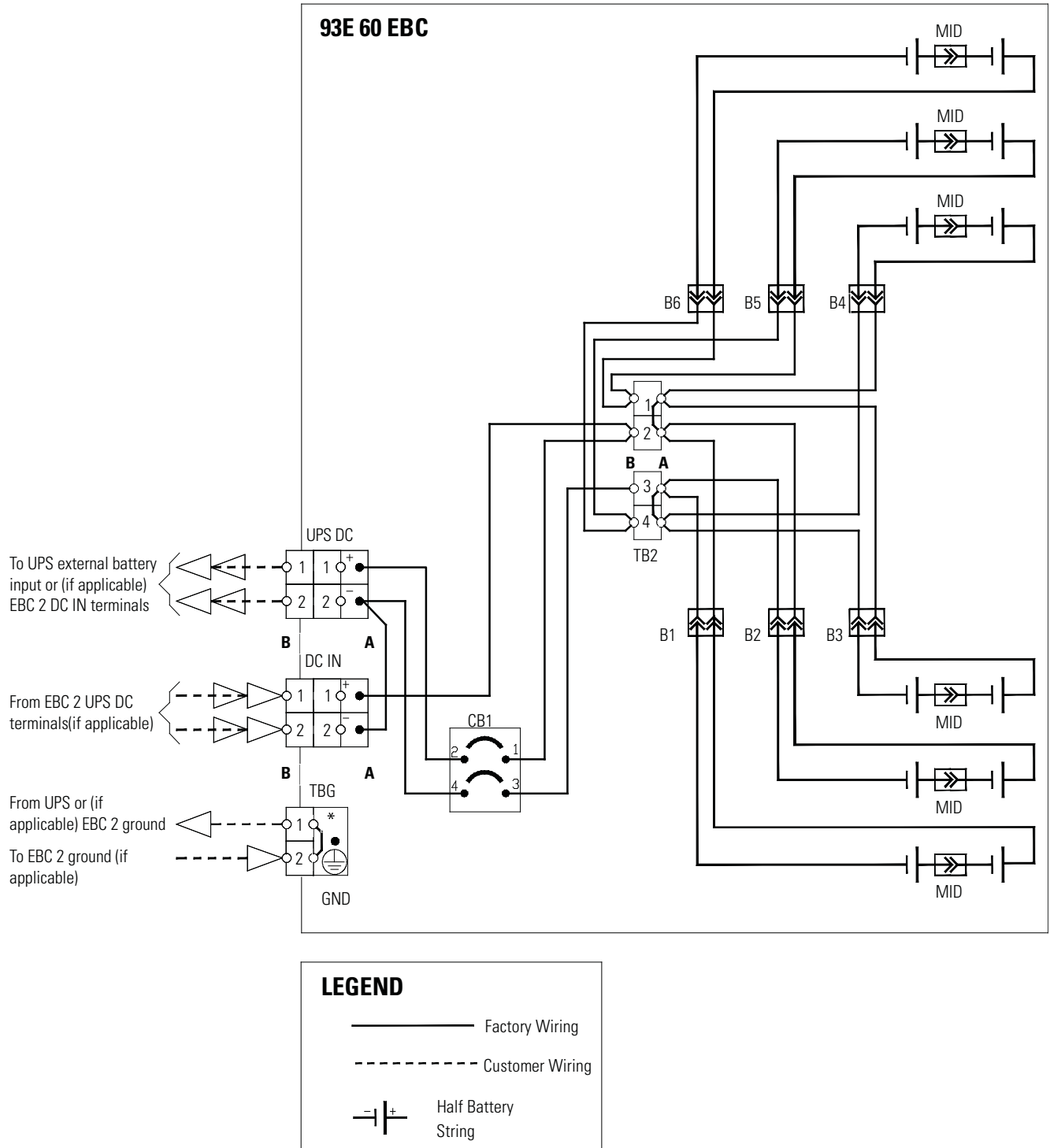


Figure 5-4. 93E 60 EBC Schematic

This page intentionally left blank.



## Chapter 6 Maintenance

The components inside the EBC are secured to a sturdy metal frame. All repairable parts and assemblies are located for easy removal, with very little disassembly. This design allows authorized service personnel to perform routine maintenance and servicing quickly.

You must schedule periodic performance checks of the UPS system to keep it running properly. Regular routine checks of operation and system parameters enable your system to function efficiently for many trouble-free years.

### 6.1 Important Safety Instructions

Remember that your UPS system is designed to supply power **EVEN WHEN DISCONNECTED FROM THE UTILITY POWER.**

---

 **WARNING**

---

- No user serviceable components.
  - Servicing and maintenance should be performed by qualified service personnel only.
  - **LETHAL VOLTAGE PRESENT.** This unit should not be operated with the cabinet doors open or protective panels removed. Do not make any assumptions about the electrical state of any cabinet in the UPS system.
- 

### 6.2 Performing Preventive Maintenance

The UPS system requires very little preventive maintenance. However, the system should be inspected periodically to verify that the units are operating normally. Record maintenance results and any corrective actions in a suitable log.

#### 6.2.1 DAILY Maintenance

Perform the following steps daily:

1. Check the area surrounding the UPS system. Ensure the area is not cluttered, allowing free access to the unit.
2. Ensure the air intakes on the Accessory cabinets are not blocked.
3. Ensure the operating environment is within the parameters specified in paragraph 3.2.1 and Chapter 7, "Product Specifications."

#### 6.2.2 PERIODIC Maintenance

Periodic inspections of the EBC should be made to determine if components, wiring, and connections exhibit evidence of overheating. Particular attention should be given to the compression lug connections. Maintenance procedures should specify that the compression lug connections be retorqued to values listed in this manual.

#### 6.2.3 ANNUAL Maintenance

Annual preventive maintenance should be performed only by authorized service personnel familiar with maintenance and servicing of the UPS system. Contact an Eaton service representative for more information about service offerings.

#### 6.2.4 BATTERY Maintenance

Contact an Eaton service representative for battery maintenance. Battery replacement and maintenance should be performed only by authorized service personnel.

### 6.3 Recycling the Used Batteries

Contact your local recycling or hazardous waste center for information on proper disposal of the used batteries or UPS.

---

 **WARNING**

---

- Do not dispose of the battery or batteries in a fire. Batteries may explode. Proper disposal of batteries is required. Refer to your local codes for disposal requirements.
  - Do not open or mutilate the battery or batteries. Released electrolyte is harmful to the skin and eyes. It may be toxic.
  - A battery can cause electrical shock, burn from high short-circuit current, or fire. Observe proper precautions.
- 

---

 **ATTENTION!**

---

- Une batterie peut présenter un risque de choc électrique, de brûlure, ou d'incendie. Suivre les précautions qui s'imposent.
  - Pour le remplacement, utiliser le même nombre et modèle des batteries.
  - L'élimination des batteries est réglementée. Consulter les codes locaux à cet effet.
- 

---

 **CAUTION**

---

Do not discard the UPS or the UPS batteries in the trash. This product contains sealed, lead-acid batteries and must be disposed of properly. For more information, contact your local recycling/reuse or hazardous waste center.

---

---

 **CAUTION**

---

Do not discard waste electrical or electronic equipment (WEEE) in the trash. For proper disposal, contact your local recycling/reuse or hazardous waste center.

---

### 6.4 Maintenance Training

A basic training course, available from Eaton Corporation, gives you a competent working knowledge of the UPS system operation and teaches you how to perform first level corrective maintenance. For more information about training and other services, contact the Help Desk (see paragraph 1.7).

## Chapter 7 Product Specifications

This section provides the following specifications:

- Model Numbers
- Battery specifications
- Battery runtimes
- Environmental and safety specifications

### 7.1 Model Numbers

The External Battery Cabinet (EBC) is available in two models to meet the needs of the Eaton 93E UPS product line.

External Battery Cabinet (EBC) Models	Description
Eaton 93E 30 EBC	EBC for Eaton 93E 30 kVA UPS
Eaton 93E 60 EBC	EBC for Eaton 93E 60 kVA UPS

### 7.2 Specifications

The following sections detail the battery specifications, battery runtimes, and the environmental and safety specifications for the UPS.

#### 7.2.1 Battery Specifications

<b>EBC Battery Type</b>	30Ah sealed, valve-regulated lead-acid (VRLA), maintenance-free, minimum 3-year float service life at 77°F (25°C), 120W/cell
<b>Number of Strings</b>	93E 30 EBC: 2 or 3 strings. 93E 60 EBC: 4 or 6 strings
<b>Battery Replacement</b>	Must be replaced by a qualified service technician
<b>Charger</b>	Service conferrable 0.5–34A per string, with overall maximum of 34A (limited by input current). Default: 3.4A per string
<b>Charging</b>	No more than 10x discharge time to 90% usable capacity at nominal line voltage after full load discharge
<b>Performance</b>	ABM technology increases battery service life, optimizes recharge time, and provides a warning before the end of useful battery life
<b>Protection</b>	93E 30 EBC output protected by 175A circuit breaker. 93E 60 EBC output protected by 350A circuit breaker.

### 7.2.2 Battery Runtimes (in Minutes) at Full load

Number of EBCs	EBC Model	Number of Battery Strings	Runtime
1	93E 30EBC	2	14
	93E 30EBC	3	26
	93E 30EBC	4	37
2	93E 30EBC	5	49
	93E 30EBC	6	62
1	93E 60EBC	4	14
	93E 60EBC	6	26
	93E 60EBC	8	37
2	93E 60EBC	10	50
	93E 60EBC	12	62

**NOTE** Battery times are approximate and vary depending on the load configuration and battery charge.

### 7.2.3 Environmental and Safety Specifications

<b>Operating Temperature</b>	32°F to 86°F (0°C to 30°C). Optimal battery performance: 77°F (25°C)
<b>Transit Temperature</b>	-13°F to 140°F (-25°C to 60°C)
<b>Storage Temperature</b>	-13°F to 131°F (-25°C to 55°C) Recommended battery storage: 59°F to 77°F (15°C to 25°C)
<b>Operating Altitude</b>	Maximum 1500m (5000 ft) at 30°C without derating
<b>Transit Altitude</b>	15000m (49213 ft)
<b>Ventilation</b>	Convection
<b>Relative Humidity (operating and storage)</b>	5% to 95% maximum noncondensing
<b>Acoustical Noise</b>	Not applicable
<b>Safety Conformance</b>	UL1778 4 <sup>th</sup> edition, UL60950-1 1 <sup>st</sup> edition
<b>Agency Markings</b>	cULus
<b>EMC (Class A)</b>	FCC Part 15 Class A and 62040-2 c3

## Warranty

### LIMITED FACTORY WARRANTY FOR THREE-PHASE EATON® 93E UPS AND 93E UPS ACCESSORY PRODUCTS

**WARRANTOR:** The warrantor for the limited warranties set forth herein is Eaton Corporation, an Ohio Corporation ("Eaton").

**LIMITED WARRANTY:** This limited warranty (this "Warranty") applies only to the original end-user (the "End-User") of the Eaton Three-Phase 93E UPS and 93E UPS Accessory Products (the "Product") and cannot be transferred. This restriction applies even in the event that the Product is initially sold by Eaton for resale to an End-User. This Warranty gives you specific legal rights, and you may also have other rights which vary from State to State (or jurisdiction to jurisdiction).

**WHAT THIS LIMITED WARRANTY COVERS:** The warrantor warrants, with the terms of this Warranty, that the Eaton three-phase UPS electronics, Eaton-built accessories, and Eaton-built battery cabinets (individually and collectively, the "Warranted Items") are free from defects in material and workmanship.

For Product installed (and currently located) in the fifty (50) United States and the District of Columbia, if, in the opinion of Eaton, a Warranted Item is defective, Eaton's sole obligation, at the option of Eaton, will be to refurbish or replace such defective Warranted Item (including the costs of providing diagnosis, service, and labor ["labor coverage"]). The defective Warranted Item will be refurbished or replaced onsite at the End-User's location or such other location as determined by Eaton. Any parts that are replaced may be new or reconditioned. All parts replaced by Eaton shall become the property of Eaton.

For Product installed (and currently located) outside the fifty (50) United States and the District of Columbia, if, in the opinion of Eaton, a Warranted Item is defective, Eaton's sole obligation, at the option of Eaton, will be to refurbish or replace such defective Warranted Item (not including the costs of labor coverage). The defective Warranted Item will be refurbished or replaced onsite at the End-User's location or such other location as determined by Eaton. Any parts that are replaced may be new or reconditioned. All parts replaced by Eaton shall become the property of Eaton.

**LIMITED WARRANTY PERIOD:** The period covered by this Warranty for Product installed (and currently located) in the fifty (50) United States and the District of Columbia is six (6) months from the date of Product purchase for labor coverage when no startup is performed by an authorized Eaton Customer Service Engineer or Agent or twelve (12) months from the date of Product purchase with startup performed by an authorized Eaton Customer Service Engineer or Agent and twelve (12) months from the date of Product purchase or eighteen (18) months from date of Product shipment, whichever occurs first, for the refurbishment/ replacement of parts.

The period covered by this Warranty for Product installed (and currently located) outside the fifty (50) United States and the District of Columbia is twelve (12) months from the date of Product purchase or eighteen (18) months from the date of Product shipment, whichever occurs first, for the refurbishment/replacement of parts.

**WHAT THIS LIMITED WARRANTY DOES NOT COVER:** This Warranty does not cover any defects or damages caused by: (a) failure to properly store the Product before installation, including the "trickle charge" of batteries no later than the date indicated on the packaging; (b) shipping and delivery of the Product if shipping is FOB Factory; (c) neglect, accident, fire, flood, lightning, vandalism, acts of God, Customer's neglect, abuse, misuse, misapplication, incorrect installation; (d) repair or alteration not authorized in writing by Eaton personnel or performed by an authorized Eaton Customer Service Engineer or Agent; or (e) improper testing, operation, maintenance, adjustment, or any modification of any kind not authorized in writing by Eaton personnel or performed by an authorized Eaton Customer Service Engineer or Agent.

This Warranty is not valid: if the Product's serial numbers have been removed or are illegible. Any Warranted Items repaired or replaced pursuant to this Warranty will be warranted for the remaining portion of the original Warranty subject to all the terms thereof. Eaton does not provide a labor warranty for Product located outside of the fifty (50) United States or the District of Columbia. **Any equipment, parts, or materials included in the Product and not manufactured by Eaton are warranted solely by the manufacturer of such equipment, parts, or materials and are not included as part of this Warranty. Batteries are not warranted by Eaton.**

**THIS WARRANTY IS THE END-USER'S SOLE REMEDY AND IS EXPRESSLY IN LIEU OF, AND THERE ARE NO OTHER, EXPRESSED OR IMPLIED GUARANTEES OR WARRANTIES (INCLUDING ANY IMPLIED WARRANTY OF MERCHANTABILITY OR FITNESS FOR ANY PURPOSE, WHICH ARE EXPRESSLY DISCLAIMED). SOME STATES OR JURISDICTIONS DO NOT ALLOW THE EXCLUSION OF EXPRESS OR IMPLIED WARRANTIES, SO THE ABOVE EXCLUSION MAY NOT APPLY TO YOU. IN THAT EVENT, SUCH WARRANTIES ARE LIMITED IN DURATION TO THE LIMITED WARRANTY PERIOD. SOME STATES OR JURISDICTIONS DO NOT ALLOW LIMITATIONS ON HOW LONG AN IMPLIED WARRANTY LASTS OR THE EXCLUSION OR LIMITATION OF INCIDENTAL OR CONSEQUENTIAL DAMAGES, SO THE ABOVE LIMITATIONS AND/OR EXCLUSIONS MAY NOT APPLY TO YOU.**

**LIMITATION OF LIABILITY:** In no event shall Eaton be liable for any indirect, incidental, special or consequential damages of any kind or type whatsoever, resulting from or in connection with any claim or cause of action, whether brought in contract or in tort (including negligence and strict liability). Some States or jurisdictions do not allow the exclusion of limitation of incidental or consequential damages, so the above limitation or exclusion may not apply to you. Eaton shall not be responsible for failure to provide service or parts due to causes beyond Eaton's reasonable control. In no case will Eaton's liability under this Warranty exceed the replacement value of the Warranted Items.

**END-USER'S OBLIGATIONS:** In order to receive the benefits of this Warranty, the End-User must register the product warranty (via mail or online at [www.powerquality.eaton.com/Product-Registration](http://www.powerquality.eaton.com/Product-Registration) "product registration"); use the Product in a normal way; follow the Product's user's guide; and protect against further damage to the Product if there is a covered defect.

**OTHER LIMITATIONS:** Eaton's obligations under this Warranty are expressly conditioned upon receipt by Eaton of all payments due to it (including interest charges, if any). During such time as Eaton has not received payment of any amount due to it for the Product, in accordance with the contract terms under which the Product is sold, Eaton shall have no obligation under this Warranty. Also during such time, the period of this Warranty shall continue to run and the expiration of this Warranty shall not be extended upon payment of any overdue or unpaid amounts.

**COSTS NOT RELATED TO WARRANTY:** The End-User shall be invoiced for, and shall pay for, all services not expressly provided for by the terms of this Warranty, including without limitation site calls involving an inspection that determines no corrective maintenance is required. Any costs for replacement equipment, installation, materials, freight charges, travel expenses, or labor of Eaton representatives outside the terms of this Warranty will be borne by the End-User.

**OBTAINING WARRANTY SERVICE:** In the USA, call the Eaton Customer Reliability Center 7x24 at 800-843-9433. Outside of the USA, call your local Eaton sales or service representative, or call the Eaton Customer Reliability Center in the United States at 919-845-3633. For comments or questions about this Limited Factory Warranty, write to the Customer Quality Representative, 8609 Six Forks Road, Raleigh, North Carolina 27615 USA.





P-16400057 4