



Powering Business Worldwide

SITE PLANNING DATA 93E 80KVA

Page 1	Packaging Dimensions
Page 2	Dimensional Drawings
Page 3	COG and Clearance Dimensions
Page 4	Customer Connections
Page 5	Electrical Wiring of Single Unit
Page 6	Electrical & Signal Wiring of Parallel Units
Page 7	Product Specifications



METRIC		THIRD ANGLE PROJECTION		EATON CORPORATION			
<small>DIMENSIONS ARE IN MILLIMETERS AFTER PLATING, DIMENSIONS AND TOLERANCES IN ACCORDANCE WITH ASME Y14.5M-1994. SEE NOTES FOR TOLERANCES.</small>							
DESCRIPTION: 93PE 80KVA							
ORIGINATED: Atif Rasheed	28-08-2015	ECO:	NAME:	REVISION: 001	SIZE: A2		
CHECKED:		DOCUMENT TYPE: AUTOCAD DRAWING		STATE: RELEASED	SCALE: 1:1		
APPROVED:					SHEET: OF		
<small>EATON CORPORATION - CONFIDENTIAL AND PROPRIETARY NOTICE TO PERSONS RECEIVING THIS DOCUMENT AND/OR TECHNICAL INFORMATION THIS DOCUMENT, INCLUDING THE DRAWING AND INFORMATION CONTAINED THEREIN, IS CONFIDENTIAL AND IS THE EXCLUSIVE PROPERTY OF EATON CORPORATION, AND IS LOANED TO YOU AND SUBJECT TO RECALL BY EATON AT ANY TIME. BY YOUR POSSESSION OF THIS DOCUMENT, THE RECIPIENT ACKNOWLEDGES AND AGREES THAT THIS DOCUMENT CANNOT BE USED IN ANY MANNER HARMFUL TO THE INTERESTS OF EATON AND THAT NO PORTION OF THIS DOCUMENT MAY BE COPIED OR OTHERWISE REPRODUCED WITHOUT THE PRIOR WRITTEN CONSENT OF EATON. IN THE CASE OF CONFLICTING CONTRACTUAL PROVISIONS, THIS NOTICE SHALL GOVERN THE STATUS OF THIS DOCUMENT. © 2011 Eaton Corporation - All Rights Reserved.</small>							

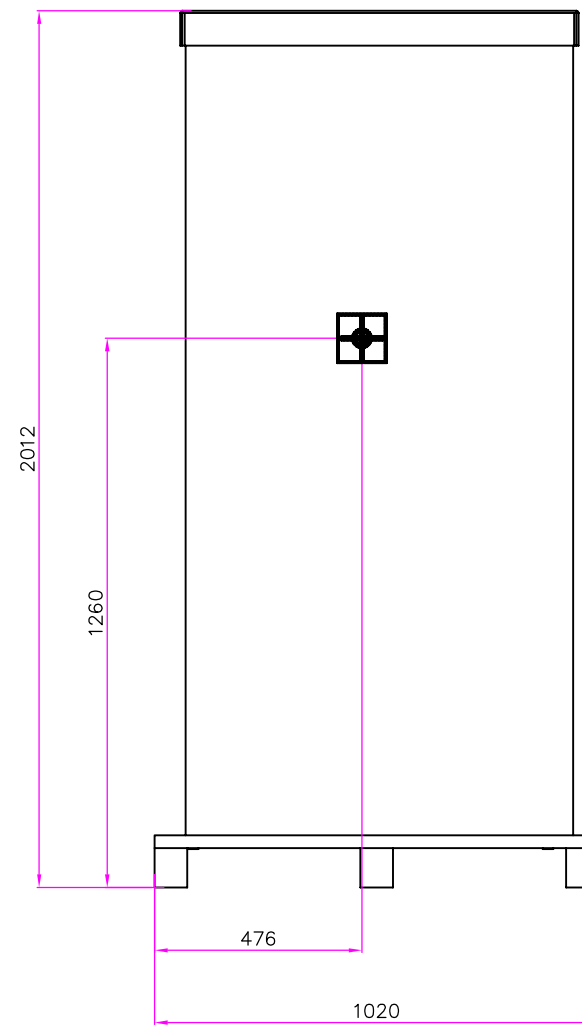
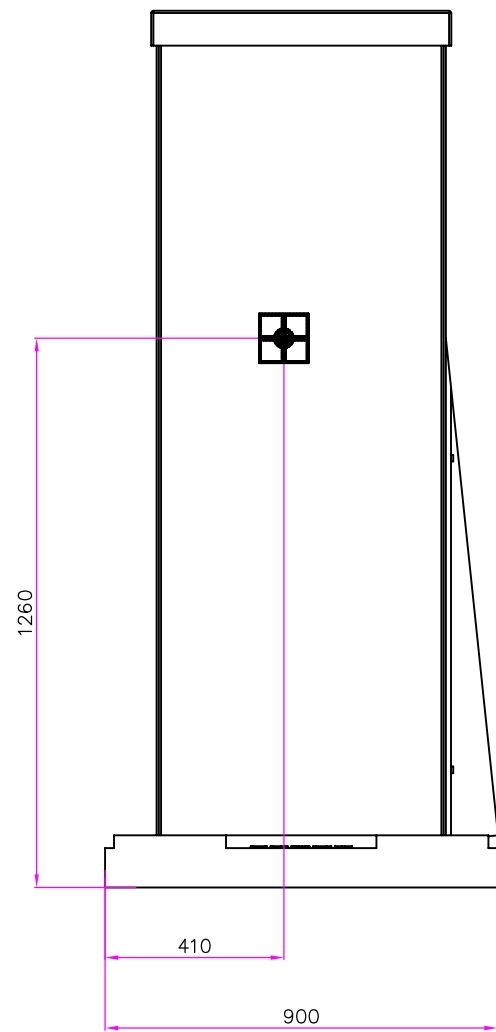



COG dimensions for 80KVA Unit

Notes:

1. The COG dimensions are approximated values with Pallet and packaging.
2. The COG dimensions for 80KVA UPS cabinet with package are X=410mm, Y=476mm, Z=1260mm.
3. Store the unit in dry and clean environment. Protect the unit from high humidity, rain or other direct exposure to water and also protect it from exposure to dirt and dust.
4. Optimal storing temperature for the unit without batteries is +15°C to +30°C and for batteries +20°C to +25°C.
5. Unites without batteries can be stored in -25°C to +55°C without risk of remediate damaging.
6. Storing batteries above +25°C will shorten the battery lifetime.
7. Batteries can be stored for six months without charging in temperature +20°C to +25°C, but batteries should not be stored uninstalled more than absolute necessary.
8. If batteries are stored above +25°C then batteries should be charged every four months.
9. Storing batteries longer than recommended without charging can harm the battery permanently.

Product Specifications

UPS Rating		Shipping Dimensions WxDxH	Approx. Weight Shipping
KVA	KW	MM	Kg
80	72	900X1020X2011	290

METRIC  EATON CORPORATION 

DIMENSIONS ARE IN MILLIMETERS AFTER PLATING, DIMENSIONS AND TOLERANCES IN ACCORDANCE WITH ASME Y14.5M-1994. SEE NOTES FOR TOLERANCES.

DESCRIPTION: 93E 80KVA Packaging Dimension

ORIGINATED: Atif Rashid	26-08-2015	ECO:	NAME:	REVISION: 001	SIZE: A2
CHECKED:		DOCUMENT TYPE: AUTOCAD DRAWING		STATE: RELEASED	SCALE: 1:12
APPROVED:					SHEET: 1 OF 7

EATON CORPORATION - CONFIDENTIAL AND PROPRIETARY
NOTICE TO PERSONS RECEIVING THIS DOCUMENT AND/OR TECHNICAL INFORMATION
THIS DOCUMENT, INCLUDING THE DRAWING AND INFORMATION CONTAINED THEREIN, IS CONFIDENTIAL AND IS THE EXCLUSIVE PROPERTY OF EATON CORPORATION AND IS LOANED TO YOU AND SUBJECT TO RECALL BY EATON AT ANY TIME.
BY USING THIS DOCUMENT, THE RECIPIENT ACKNOWLEDGES AND AGREES THAT THIS DOCUMENT CANNOT BE USED IN ANY MANNER HARMFUL TO THE INTERESTS OF EATON AND THAT NO PORTION OF THIS DOCUMENT MAY BE COPIED OR OTHERWISE REPRODUCED WITHOUT THE PRIOR WRITTEN CONSENT OF EATON. IN THE CASE OF CONFLICTING CONTRACTUAL PROVISIONS, THIS NOTICE SHALL GOVERN THE STATUS OF THIS DOCUMENT.
© 2011 Eaton Corporation - All Rights Reserved.

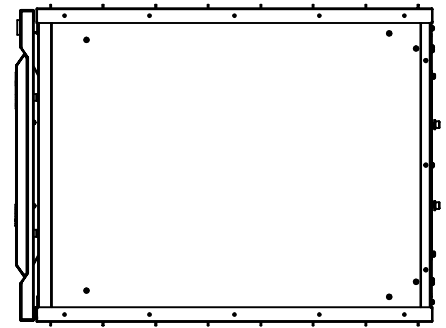

TOP VIEW

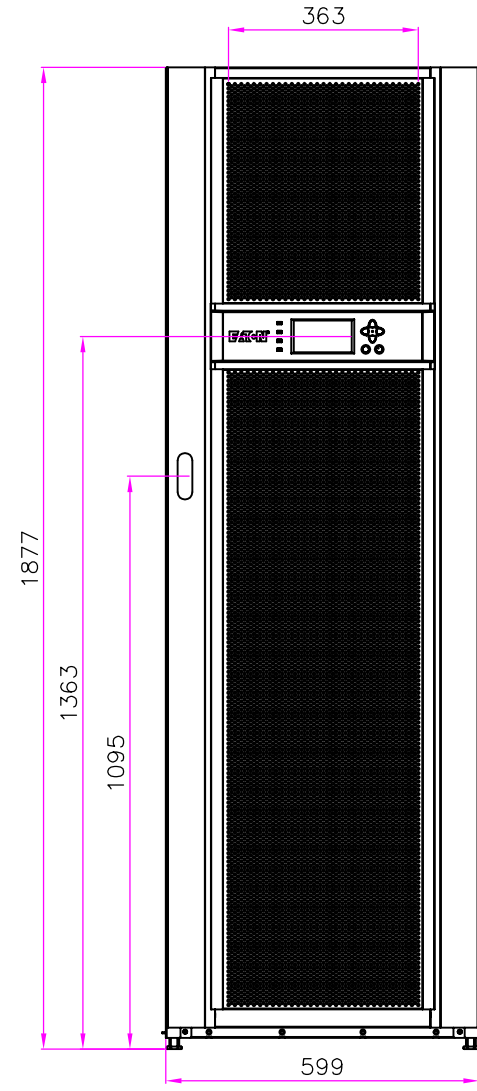

FRONT VIEW

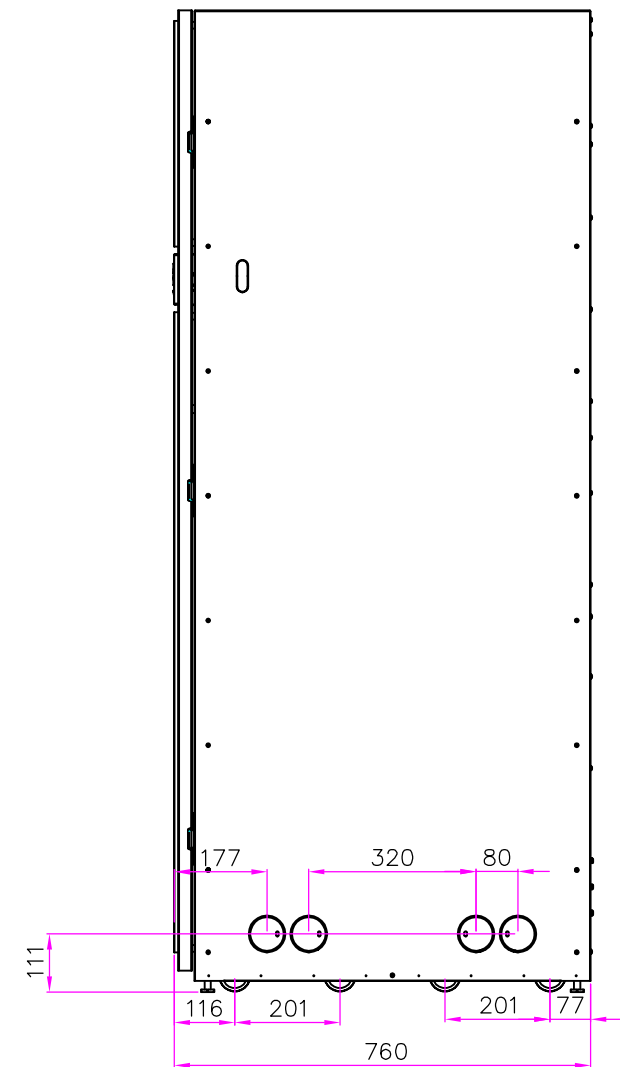

RIGHT VIEW

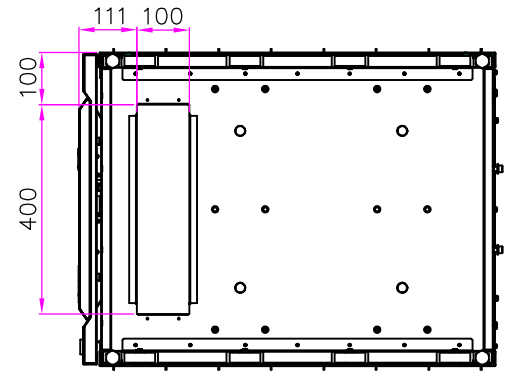

BOTTOM VIEW

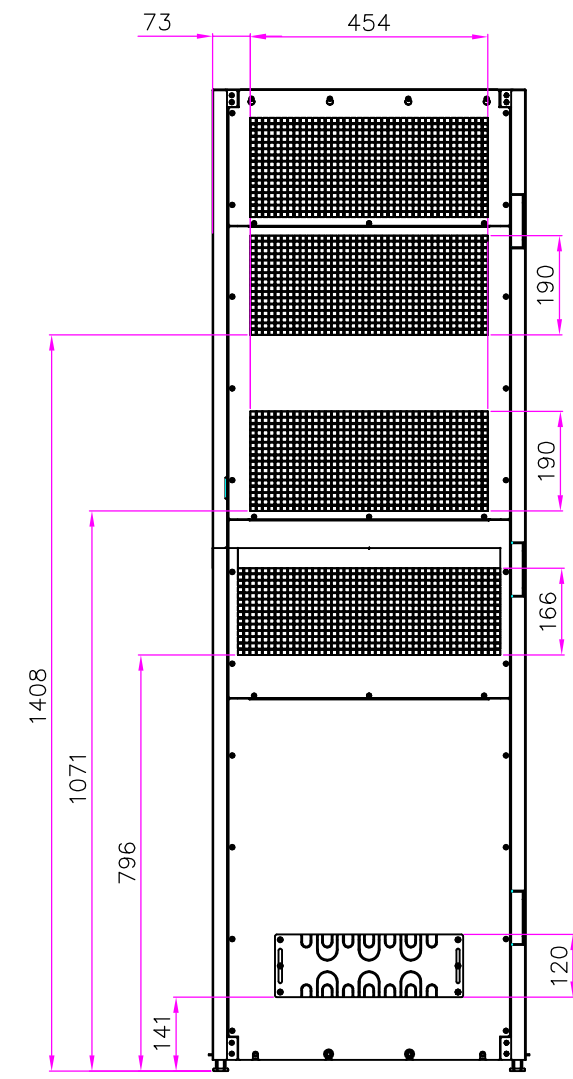

REAR VIEW

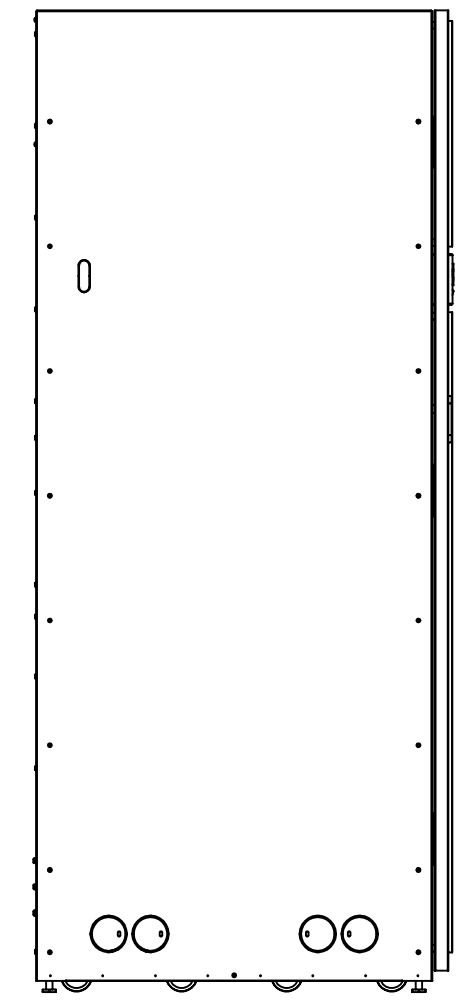

LEFT VIEW

Product Specifications

UPS Rating		Max Heat Dissipation at 100% Load	Cabinet Dimensions WXD _X H	Shipping Dimensions WXD _X H	Approx. Weight Cabinet	Approx. Weight Shipping	Point Landing	Cooling Air
KVA	KW	KW	MM	MM	Kg	Kg	Points/Kg	L/s
80	72	4.57	600X796X1876	900X1020X2011	250	290	8/31	442

- Notes:
1. The system must be installed in a temperature and humidity controlled indoor area free of conductive contaminants.
 2. Continues ambient temperature range: 0–40°C (32–104F); Maximum relative humidity: 95% non-condensing.
 3. The UPS can be installed in line-up-and-match or standalone configurations.
 4. The rear cable entries through the removable access gland plate are standard. Access plates shall be custom-modified to suit conduit sizes.

METRIC		THIRD ANGLE PROJECTION		EATON CORPORATION			EATON	
DIMENSIONS ARE IN MILLIMETERS AFTER PLATING, DIMENSIONS AND TOLERANCES IN ACCORDANCE WITH ASME Y14.5M-1994. SEE NOTES FOR TOLERANCES.								
DESCRIPTION: 93E 80KVA Dimensional Drawing								
ORIGINATED: Atif Rashid	26-08-2015	ECO:	NAME:			REVISION: 001	SIZE: A2	
MODIFIED:						SCALE: 1:10		
CHECKED:		DOCUMENT TYPE:				STATE: RELEASED	SHEET: 2 OF 7	
SAFETY:		AUTOCAD DRAWING						
APPROVED:								
<small>EATON CORPORATION - CONFIDENTIAL AND PROPRIETARY NOTICE TO PERSONS RECEIVING THIS DOCUMENT AND/OR TECHNICAL INFORMATION THIS DOCUMENT, INCLUDING THE DRAWING AND INFORMATION CONTAINED THEREIN, IS CONFIDENTIAL AND IS THE EXCLUSIVE PROPERTY OF EATON CORPORATION AND IS LOANED AND SUBJECT TO RECALL BY EATON AT ANY TIME. BY TAKING POSSESSION OF THIS DOCUMENT, THE RECIPIENT ACKNOWLEDGES AND AGREES THAT THIS DOCUMENT CANNOT BE USED IN ANY MANNER CONTRARY TO THE INTERESTS OF EATON AND THAT NO PORTION OF THIS DOCUMENT MAY BE COPIED OR OTHERWISE REPRODUCED WITHOUT THE PRIOR WRITTEN CONSENT OF EATON. IN THE CASE OF CONFLICTING CONTRACTUAL PROVISIONS, THIS NOTICE SHALL GOVERN THE STATUS OF THIS DOCUMENT. © 2011 Eaton Corporation - All Rights Reserved.</small>								

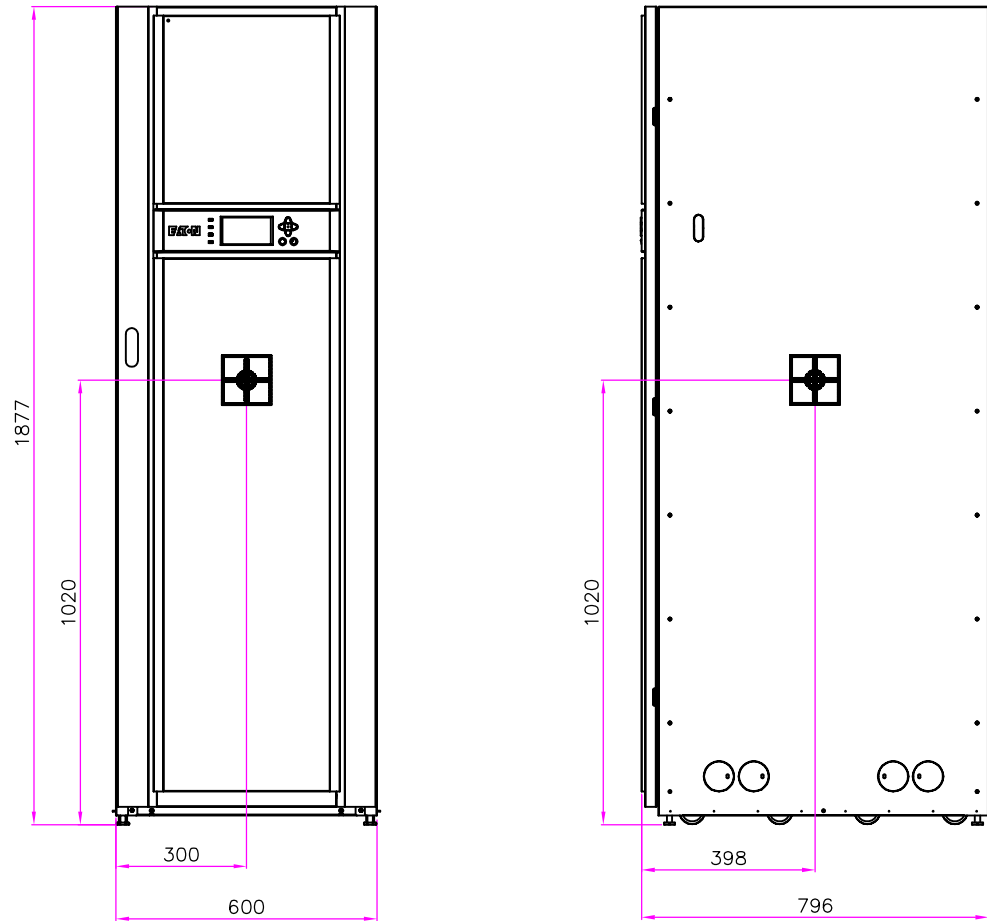

COG dimensions for 80KVA Unit

Cabinet Installation Clearances	
From Top of cabinet	300 mm
From Front of cabinet	900 mm
From Back of cabinet ⁵	150 mm

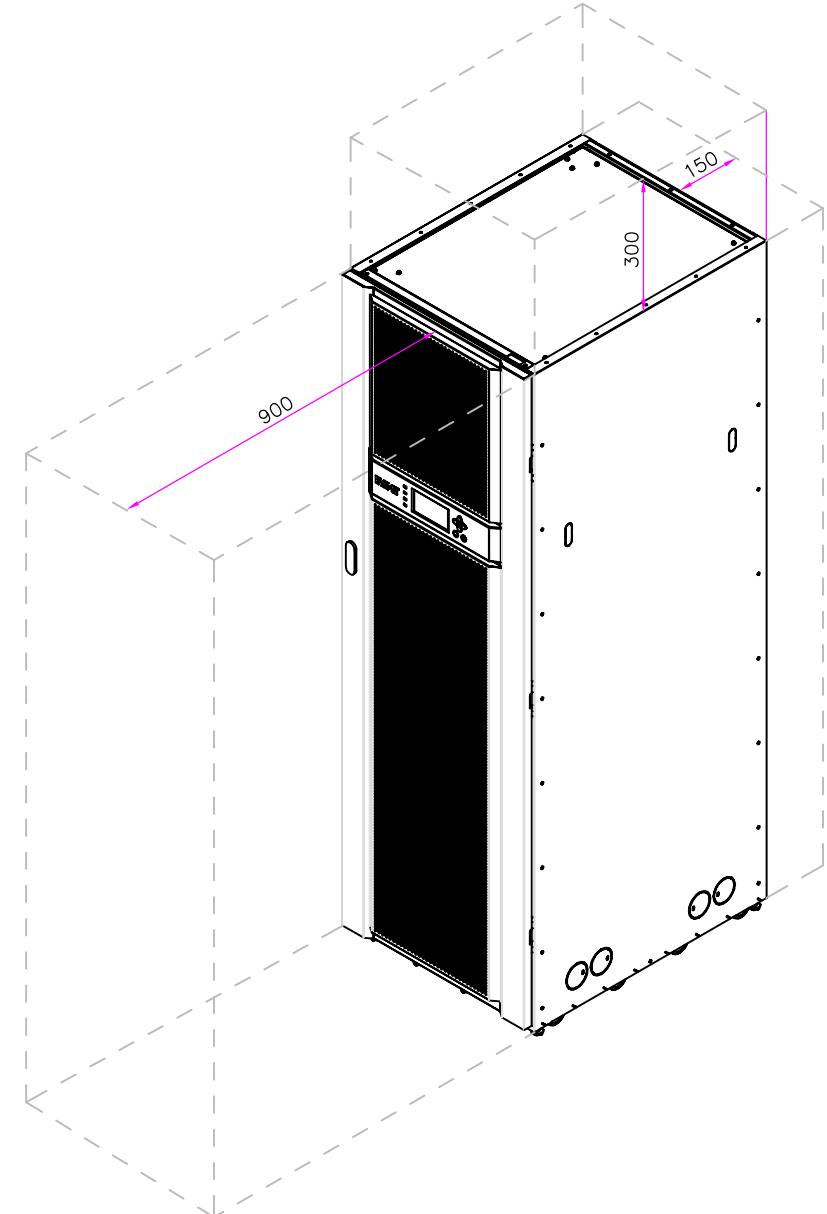

- Notes:
1. The COG dimensions for UPS cabinet are approximated values.
 2. The COG dimensions for 80KVA UPS cabinet without package are X=300mm , Y=398mm, Z=1020mm.
 3. Minimum overhead clearance above the UPS cabinet is 300mm (12in.) for servicing space.
 4. Minimum 900mm (35in.) clearance in front of the UPS cabinet is required for cooling air intake and servicing space.
 5. Minimum 150mm (5in.) clearance in back of the UPS cabinet is required for cooling air exhaust and servicing space at a ambient temperature of 25–30°C. If the ambient temperature is around 35–40°C then minimum of 200mm clearance is required.

METRIC	THIRD ANGLE PROJECTION	EATON CORPORATION		EATON	
DIMENSIONS ARE IN MILLIMETERS AFTER PLATING, DIMENSIONS AND TOLERANCES IN ACCORDANCE WITH ASME Y14.5M-1994. SEE NOTES FOR TOLERANCES.					
DESCRIPTION: 93E 80KVA Clearance and COG					
ORIGINATED: Atif Rashid	26-08-2015	ECO:	NAME:	REVISION: 001	SIZE: A2
MODIFIED:		DOCUMENT TYPE: AUTOCAD DRAWING		STATE: RELEASED	SCALE: 1:12
CHECKED:					SHEET: 3 OF 7
SAFETY:					
APPROVED:					
<small>EATON CORPORATION - CONFIDENTIAL AND PROPRIETARY NOTICE TO PERSONS RECEIVING THIS DOCUMENT AND/OR TECHNICAL INFORMATION THIS DOCUMENT, INCLUDING THE DRAWING AND INFORMATION CONTAINED THEREIN, IS CONFIDENTIAL AND IS THE EXCLUSIVE PROPERTY OF EATON CORPORATION AND IS LOANED TO YOU AND SUBJECT TO RECALL BY EATON AT ANY TIME. BY TAKING POSSESSION OF THIS DOCUMENT, THE RECIPIENT ACKNOWLEDGES AND AGREES THAT THIS DOCUMENT CANNOT BE USED IN ANY MANNER HARMFUL TO THE INTERESTS OF EATON AND THAT NO PORTION OF THIS DOCUMENT MAY BE COPIED OR OTHERWISE REPRODUCED WITHOUT THE PRIOR WRITTEN CONSENT OF EATON. IN THE CASE OF CONFLICTING CONTRACTUAL PROVISIONS, THIS NOTICE SHALL GOVERN THE STATUS OF THIS DOCUMENT. © 2011 Eaton Corporation - All Rights Reserved.</small>					

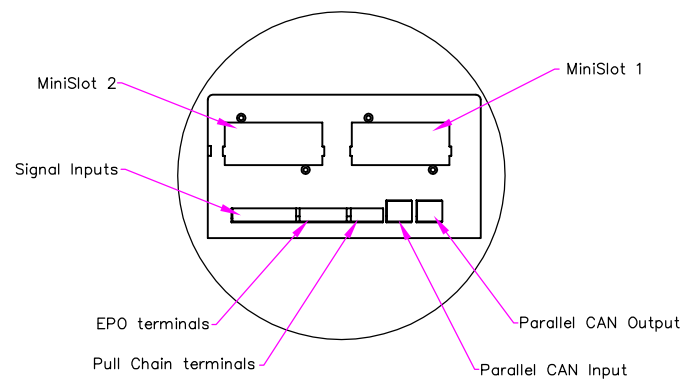

Interface Terminals
Detail B

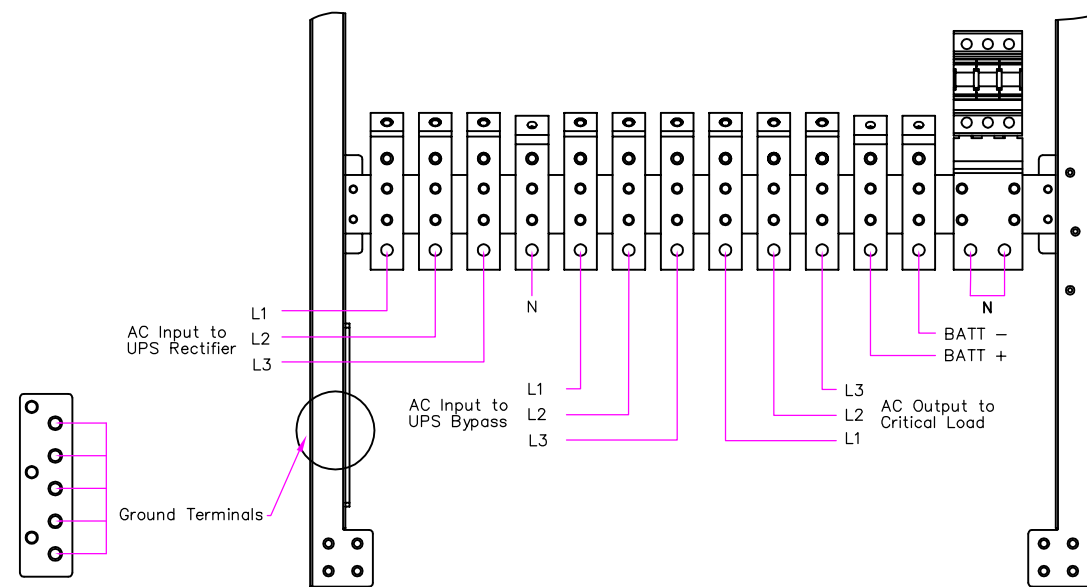
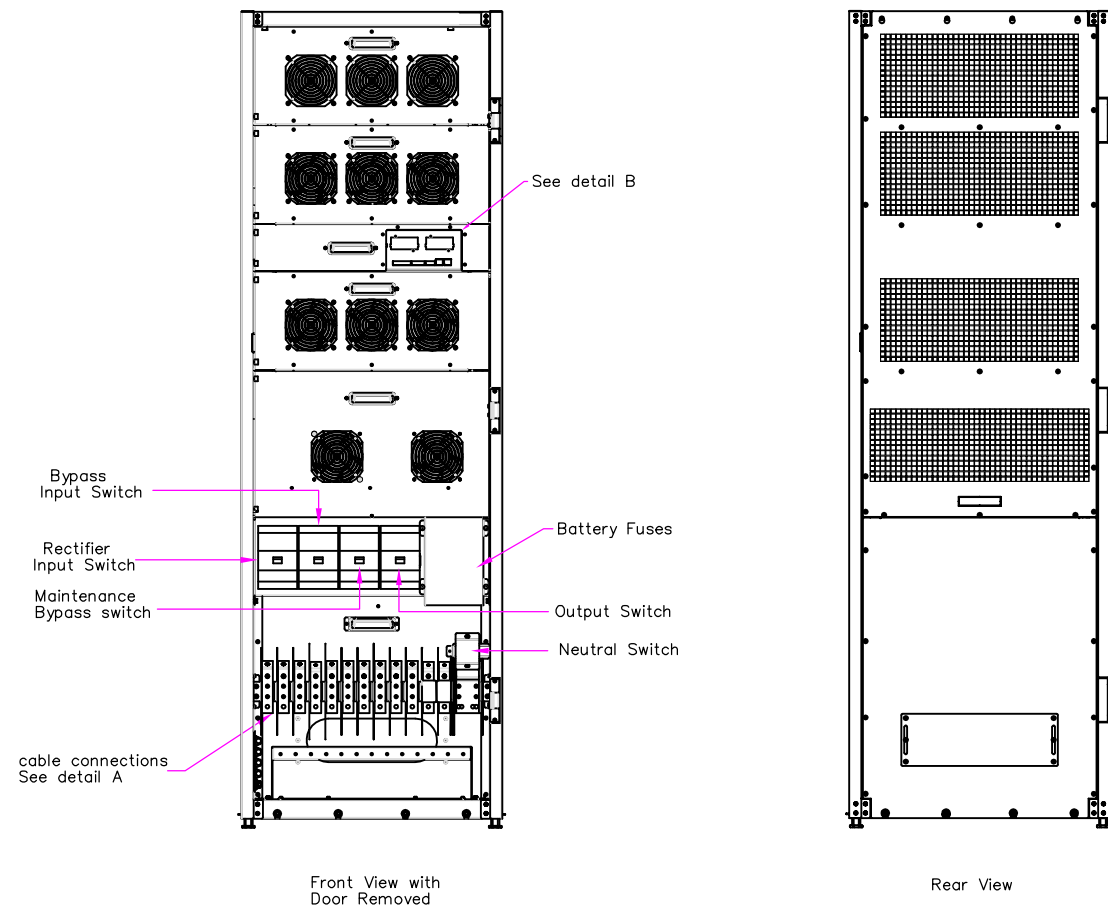

Power cable connections
Detail A

Notes:

1. M8 size power cable terminals are used for UPS input, output (L1,L2,L3,N) and PE connections. It requires approximately 12Nm of tightening torque.

METRIC		THIRD ANGLE PROJECTION		EATON CORPORATION		EATON	
DIMENSIONS ARE IN MILLIMETERS AFTER PLATING, DIMENSIONS AND TOLERANCES IN ACCORDANCE WITH ASME Y14.5M-1994. SEE NOTES FOR TOLERANCES.							
DESCRIPTION: 93E 80KVA Customer Connections							
ORIGINATED: Atif Rashid	26-08-2015	ECO:	NAME:	REVISION: 001	SIZE: A2		
MODIFIED:				STATE: RELEASED	SCALE: 1:12		
CHECKED:		DOCUMENT TYPE: AUTOCAD DRAWING			SHEET: 4 OF 7		
SAFETY:							
APPROVED:							
<small>EATON CORPORATION - CONFIDENTIAL AND PROPRIETARY NOTICE TO PERSONS RECEIVING THIS DOCUMENT AND/OR TECHNICAL INFORMATION THIS DOCUMENT, INCLUDING THE DRAWING AND INFORMATION CONTAINED THEREIN, IS CONFIDENTIAL AND IS THE EXCLUSIVE PROPERTY OF EATON CORPORATION, AND IS MERELY ON LOAN AND SUBJECT TO RECALL BY EATON AT ANY TIME. BY TAKING POSSESSION OF THIS DOCUMENT, THE RECEIVER ACKNOWLEDGES AND AGREES THAT THIS DOCUMENT CANNOT BE USED IN ANY MANNER HARMFUL TO THE INTERESTS OF EATON AND THAT NO PORTION OF THIS DOCUMENT MAY BE COPIED OR OTHERWISE REPRODUCED WITHOUT THE PRIOR WRITTEN CONSENT OF EATON. IN THE CASE OF CONFLICTING CONTRACTUAL PROVISIONS, THIS NOTICE SHALL GOVERN THE STATUS OF THIS DOCUMENT. © 2011 Eaton Corporation - All Rights Reserved.</small>							

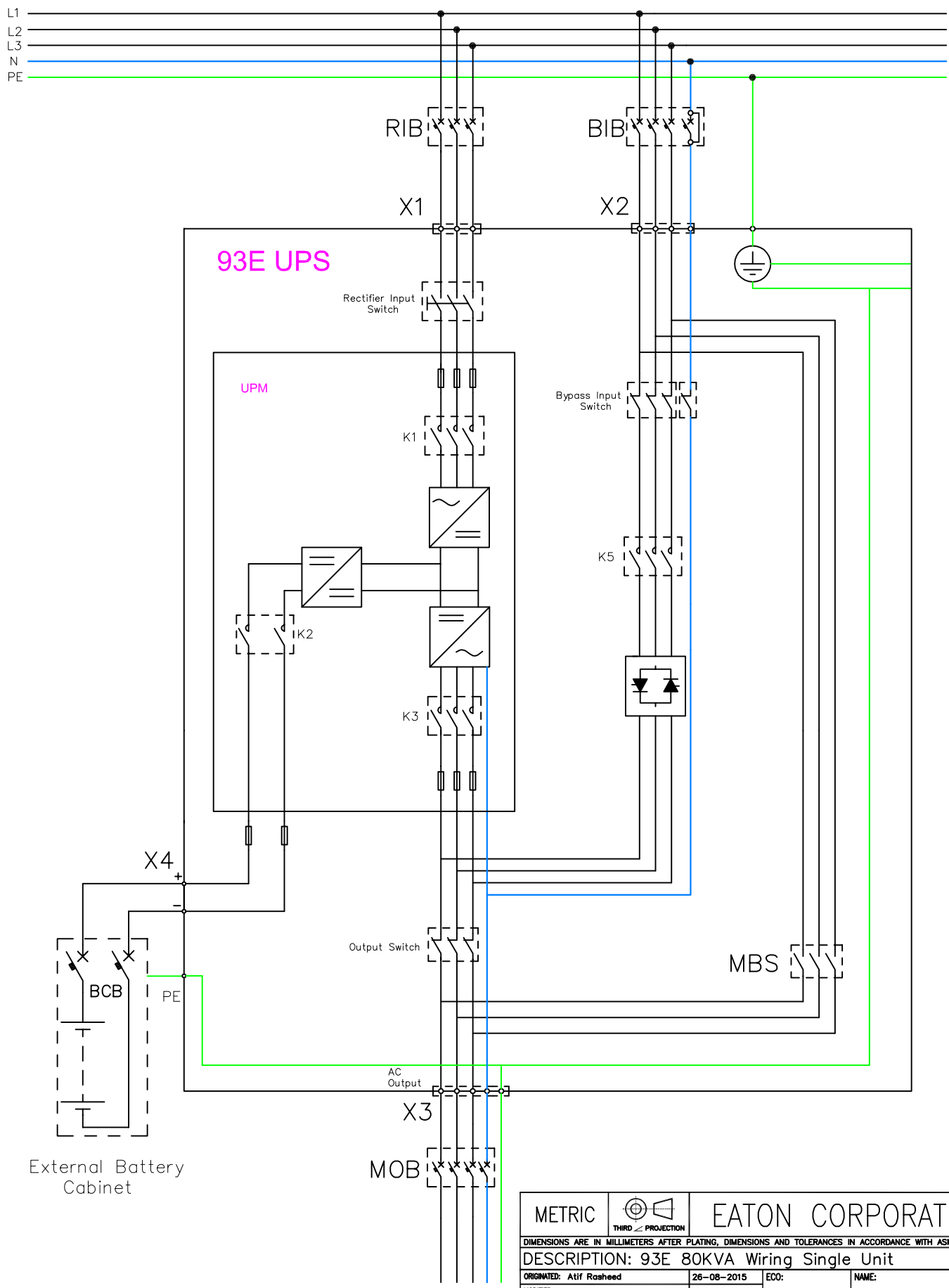

METRIC		EATON CORPORATION	
THIRD ANGLE PROJECTION			
DIMENSIONS ARE IN MILLIMETERS AFTER PLATING, DIMENSIONS AND TOLERANCES IN ACCORDANCE WITH ASME Y14.5M-1994. SEE NOTES FOR TOLERANCES.			
DESCRIPTION: 93E 80KVA Wiring Single Unit			
ORIGINATED: Atif Rasheed	26-08-2015	ECO:	NAME:
MODIFIED:			REVISION: 001
CHECKED:		DOCUMENT TYPE: AUTOCAD DRAWING	STATE: RELEASED
SAFETY:			SHEET: 5 OF 7
APPROVED:			

EATON CORPORATION - CONFIDENTIAL AND PROPRIETARY
NOTICE TO PERSONS RECEIVING THIS DOCUMENT AND/OR TECHNICAL INFORMATION
THIS DOCUMENT, INCLUDING THE DRAWING AND INFORMATION CONTAINED THEREIN, IS CONFIDENTIAL AND IS THE EXCLUSIVE PROPERTY OF EATON CORPORATION, AND IS LOANED AND SUBJECT TO RECALL BY EATON AT ANY TIME.
BY MAKING PROVISIONS OF THIS DOCUMENT, THE RECEIVER ACKNOWLEDGES AND AGREES THAT THIS DOCUMENT CANNOT BE USED IN ANY MANNER HARMFUL TO THE INTERESTS OF EATON AND THAT NO PORTION OF THIS DOCUMENT MAY BE COPIED OR OTHERWISE REPRODUCED WITHOUT THE PRIOR WRITTEN CONSENT OF EATON. IN THE CASE OF CONFLICTING CONTRACTS, PROVISIONS, THIS NOTICE SHALL GOVERN THE STATUS OF THIS DOCUMENT.
© 2011 Eaton Corporation - All Rights Reserved.

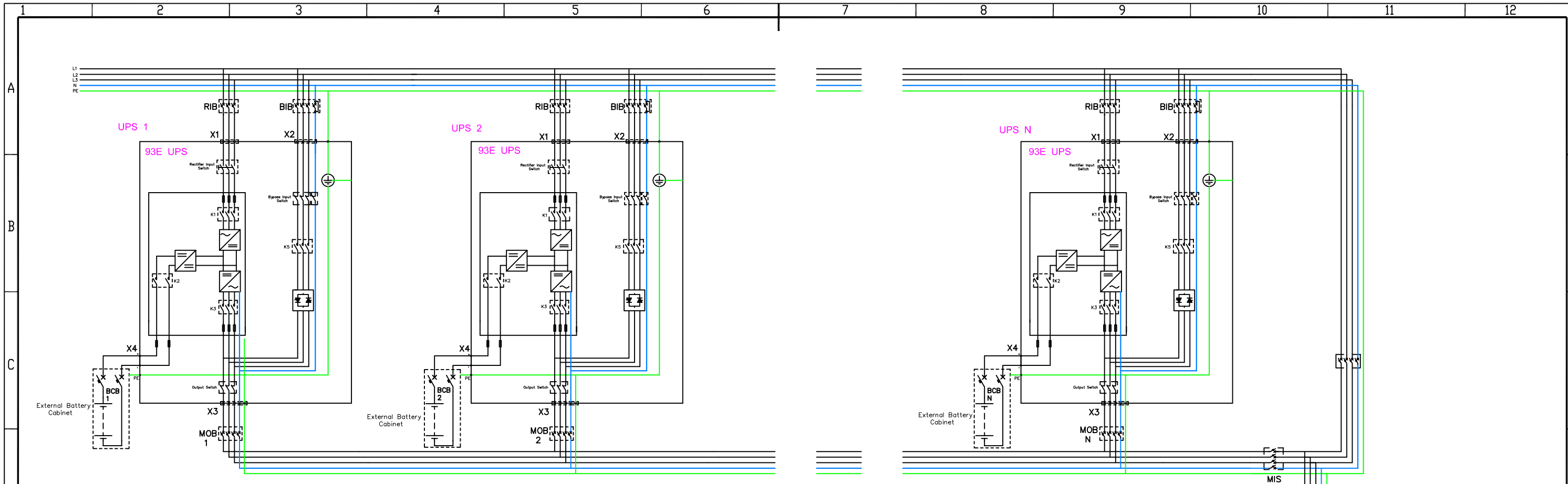

POWER WIRING

SIGNAL WIRING

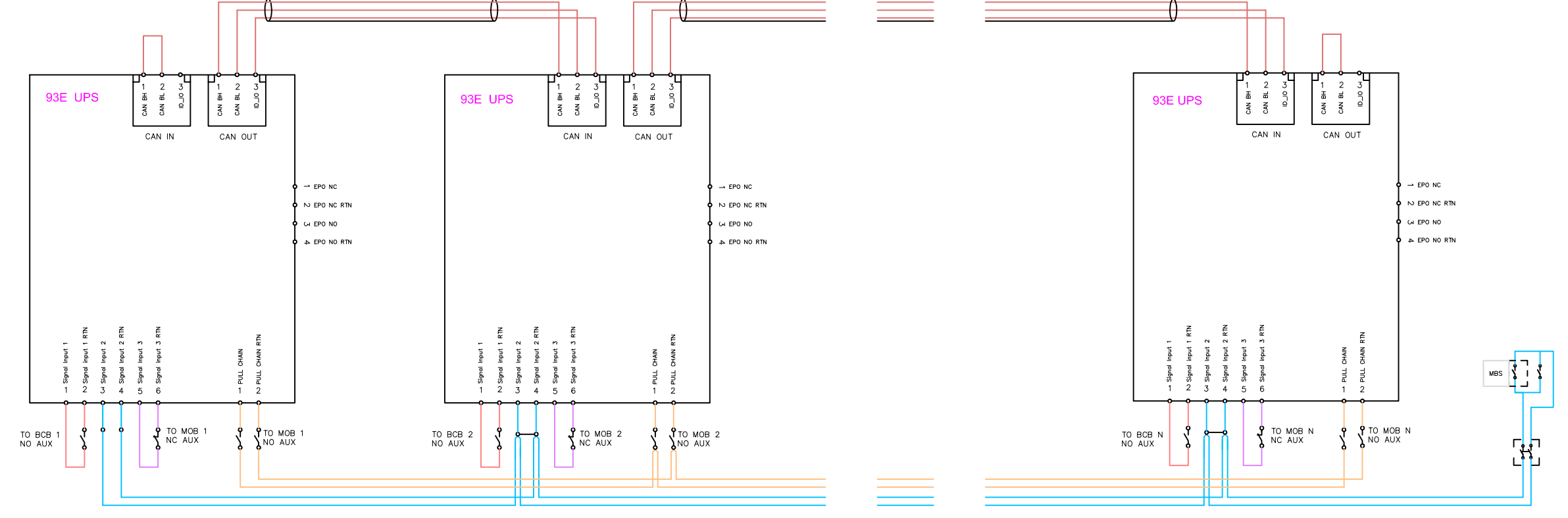

- █ MBS STATUS (Provided by others, Installed by others)
0.75 - 2.5mm² twisted pair (if possible, else shielded)
No earth needed
- █ PULL CHAIN (REDUNDANT ON BYP STATUS)
Provided by Eaton, Installed by Eaton
- █ MOB STATUS (Provided by others, Installed by others)
0.75 - 2.5mm² twisted pair (if possible, else shielded)
No earth needed
- █ PCAN (DUAL AS OPTION)
Provided by Eaton, Installed by Eaton

METRIC		EATON CORPORATION	
THIRD ANGLE PROJECTION			
DIMENSIONS ARE IN MILLIMETERS AFTER PLATING, DIMENSIONS AND TOLERANCES IN ACCORDANCE WITH ASME Y14.5M-1994. SEE NOTES FOR TOLERANCES.			
DESCRIPTION: 93E 80KVA Wiring Parallel Units			
ORIGINATED: Atif Rasheed	26-08-2015	ECO:	NAME:
MODIFIED:		DOCUMENT TYPE:	REVISION: 001
CHECKED:		AUTOCAD DRAWING	STATE: RELEASED
SAFETY:			SHEET: 6 OF 7
APPROVED:			

EATON CORPORATION - CONFIDENTIAL AND PROPRIETARY
 NOTICE TO PERSONS RECEIVING THIS DOCUMENT AND/OR TECHNICAL INFORMATION
 THIS DOCUMENT, INCLUDING THE DRAWING AND INFORMATION CONTAINED THEREIN, IS CONFIDENTIAL AND IS THE EXCLUSIVE PROPERTY OF EATON CORPORATION, AND IS LOANED AND SUBJECT TO RECALL BY EATON AT ANY TIME.
 BY USING OR RECEIVING THIS DOCUMENT, THE RECEIVER ACKNOWLEDGES AND AGREES THAT THIS DOCUMENT CANNOT BE USED IN ANY MANNER, OR IN THE INTERESTS OF EATON AND THAT NO PORTION OF THIS DOCUMENT MAY BE COPIED OR OTHERWISE REPRODUCED WITHOUT THE PRIOR WRITTEN CONSENT OF EATON. IN THE CASE OF CONFLICTING CONTRACTUAL PROVISIONS, THIS NOTICE SHALL GOVERN THE STATUS OF THIS DOCUMENT.
 © 2011 Eaton Corporation - All Rights Reserved.

93E 80KVA UPS Site Planning Data

Product Specifications

UPS Rating		AC Input	3P Rectifier Input Breaker (RIB)		3P+Bolted N Bypass Input Breaker (BIB)		AC Output	4P Inverter AC output Breaker MOB			Battery Breaker (BCB) (Ratings at the end of discharge, 1.67VPC) (36 Blocks)			For Single Unit Maintenance Bypass Switch (MBS)	For Parallel Units Common Maintenance Bypass Switch (MBS)		
			Nominal Current	Maximum Current	Nominal Current at 400v Input	Maximum Current at 15% under voltage		Output Current	Inverter Short Circuit Current	Auxiliary Switches	Rating	Battery end of discharge current	Auxiliary Switches	Rating	Rating	Auxiliary Switches	
KVA	KW	v	A	A	A	A	v	A	A / 0...100ms	A / 100...160ms	Qty	VDC	A	Qty	A	A	Qty
80	72	400	123	136	115	133	400	115	241	152	1	500	217	1	115	115 X N	1

Minimum recommended cable and fuse sizes

UPS RATING KVA	Rectifier Input Cable [mm ²] (3P)	Rectifier Fuse [A]	Bypass Input Cable [mm ²] (3P+N)	Bypass Fuse [A]	Bypass Input Cable [mm ²] (3P+N)	Bypass Fuse [A]	PE Cable [mm ²]	POS. & NEG. Line [mm ²]	Battery Fuse [A]
80	1 x 70	160	1 x 50	125	1 x 50	125	1 x 35	2 x 50	250

Notes:

1. Rectifier AC input current calculations: Nominal – 100% load without charging; Maximum – 100% load with maximum charging (Rectifier current limit).
2. Inverter AC output current calculation: At 100% rated output load.
3. The system must be installed on a level floor suitable for computer or electronic equipment.
4. All wiring and installations must be in accordance with applicable National and Local Electric Regulations.
5. AC input to UPS: (3) phases, (1) neutral, (1) ground.
AC output to load: (3) phases, (1) neutral, (1) ground.
DC input from battery to UPS: (1) positive, (1) negative, (1) ground.
6. All breakers should be adjusted according to the specified Ampere values to protect the UPS and installation.
7. For UPS installation that utilizes single feed input, The input breaker should be configured according to the rated rectifier input current.
8. Cable sizing is based on the standard IEC 60364-5-52 and IEC 60364-5-54. The sizing is for 70°C rated copper cables.
8. Specifications are subject to change.

METRIC		EATON CORPORATION		
DIMENSIONS ARE IN MILLIMETERS AFTER PLATING, DIMENSIONS AND TOLERANCES IN ACCORDANCE WITH ASME Y14.5M-1994. SEE NOTES FOR TOLERANCES.				
DESCRIPTION: 93E 80KVA Specifications				
ORIGINATED: Atif Rasheed	28-08-2015	ECO:	NAME:	REVISION: 001
MODIFIED:		DOCUMENT TYPE:		SCALE: 1:1
CHECKED:		SAFETY:		STATE: RELEASED
APPROVED:				SHEET: 7 OF 7
EATON CORPORATION - CONFIDENTIAL AND PROPRIETARY NOTICE TO PERSONS RECEIVING THIS DOCUMENT AND/OR TECHNICAL INFORMATION THIS DOCUMENT, INCLUDING THE DRAWING AND INFORMATION CONTAINED THEREIN, IS CONFIDENTIAL AND IS THE EXCLUSIVE PROPERTY OF EATON CORPORATION, AND IS LOANED AND SUBJECT TO RECALL BY EATON AT ANY TIME. BY THEIR POSSESSION OF THIS DOCUMENT, THE RECEIPTS ACKNOWLEDGES AND AGREES THAT THIS DOCUMENT CANNOT BE USED IN ANY MANNER CONTRARY TO THE INTERESTS OF EATON AND THAT NO PORTION OF THIS DOCUMENT MAY BE COPIED OR OTHERWISE REPRODUCED WITHOUT THE PRIOR WRITTEN CONSENT OF EATON. IN THE CASE OF CONFLICTING CONTRACTUAL PROVISIONS, THIS NOTICE SHALL GOVERN THE STATUS OF THIS DOCUMENT. © 2011 Eaton Corporation - All Rights Reserved.				