

CONNECTION AND FUNCTIONAL DIAGRAM

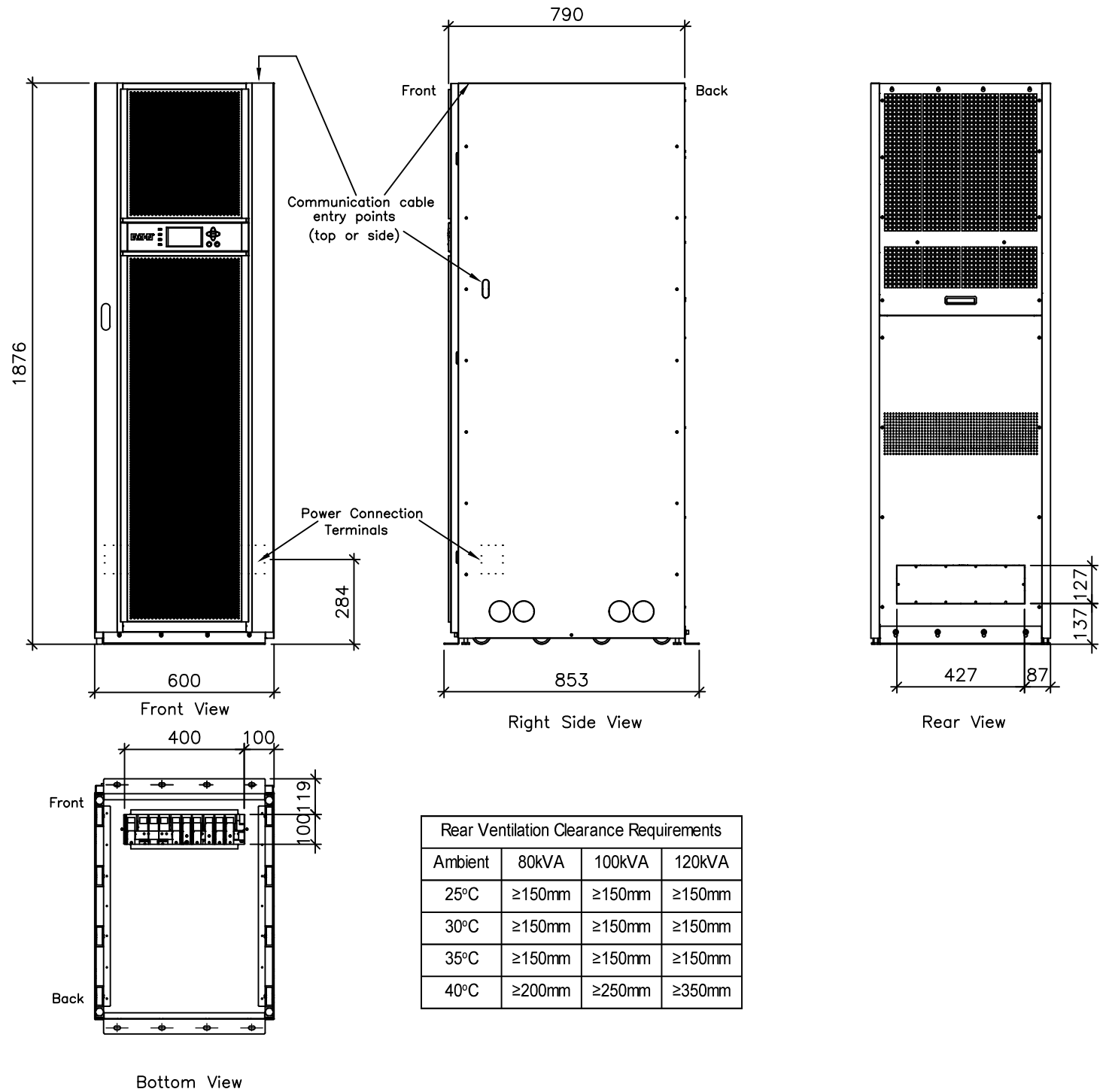
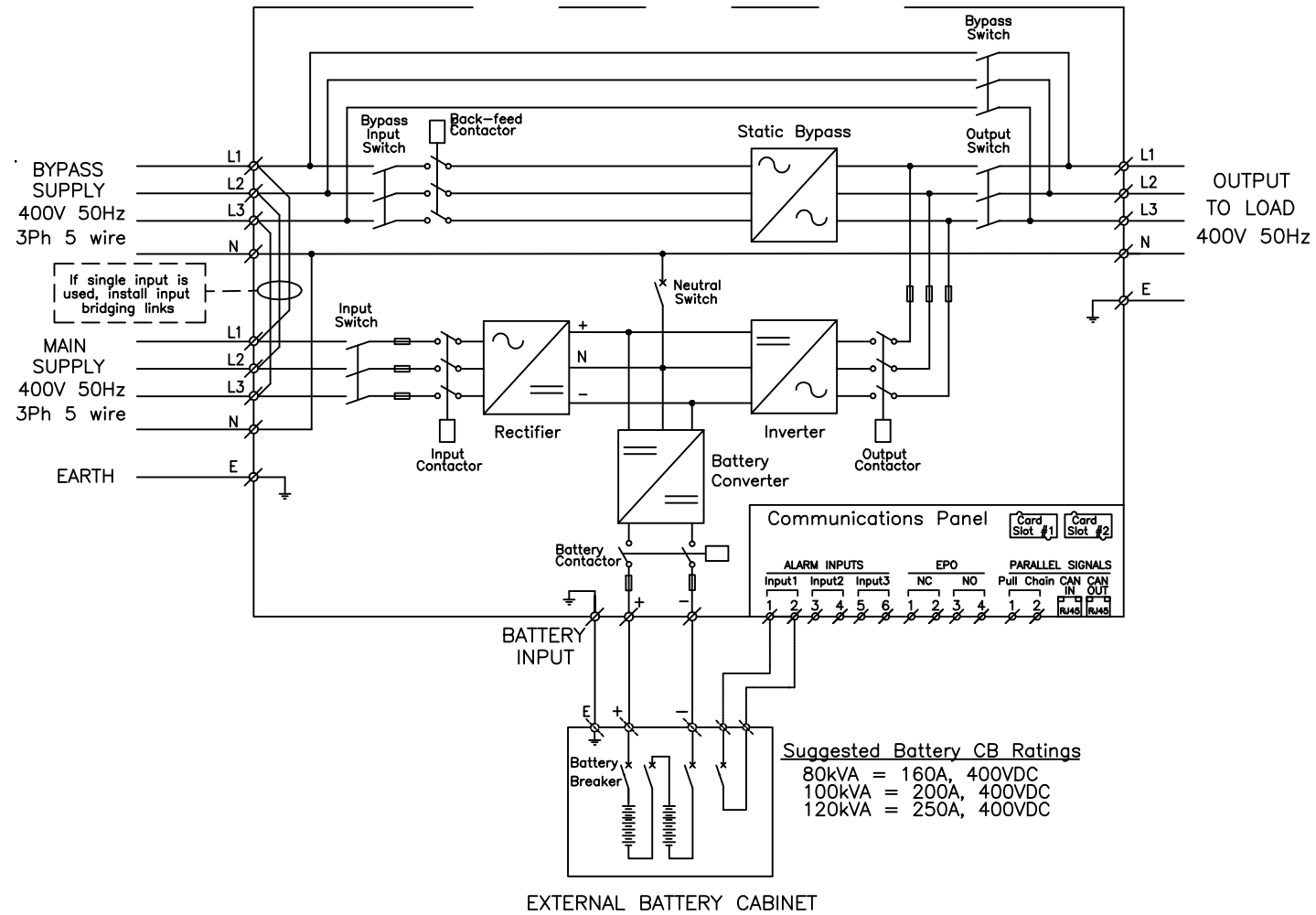

Rear Ventilation Clearance Requirements

Ambient	80kVA	100kVA	120kVA
25°C	≥150mm	≥150mm	≥150mm
30°C	≥150mm	≥150mm	≥150mm
35°C	≥150mm	≥150mm	≥150mm
40°C	≥200mm	≥250mm	≥350mm

Note: The system must be installed on a level floor and in a clean environment suitable for electronic equipment.

- Ambient temperature range: 0–40C; Recommended operating range: 20–25C; Maximum relative humidity: 95% non-condensing.
- Minimum Clearances for ventilation & service around the UPS cabinet are:
Overhead of UPS: 500mm clearance required for ventilation
Rear of UPS: Observe minimum clearance requirement for air flow. Refer to table.
Front : 900mm clearance in front of the UPS cabinet is required for User & Service Access
Side : No clearance required
- Bottom cable entry at front of cabinet or rear entry through removable gland plate
- All wiring and cabling is to be in accordance with National and Local Electrical Standards
- No provision for batteries within UPS cabinet
- Cabinet shown with bolt-down brackets fitted. These can be removed, UPS is fitted with wheels and levelling screws

UPS Installation Specifications

UPS Rating	Rated AC Input Voltage	Rated AC Output Voltage	Rectifier AC Input Current		Bypass Input current		Battery Current (40 batteries, 100% load at end of discharge)	Inverter AC Output Current	Input & Output cable max. size	Battery cable max. size	Earth cable max. size	Net Weight	Floor loading		Air Flow Requirement	
			Nominal	Maximum	Nominal	Maximum							Point Loading	Distributed Loading		
kVA	kW	VOLT	VOLT	AMP	AMP	AMP	AMP	AMP	mm ²	mm ²	mm ²	kg	Points/kg	kg/m ²	Litres/s	
80	72	400/230 -15%, +20%	400/230	125	131	115	133	193	115	95	120	95	283	8/35	590	300
100	90			154	164	144	166	241	144	95	120	95	283	8/35	590	350
120	108			187	197	173	199	290	173	120	150	120	311	8/39	648	400

*Drawings and UPS Specifications are subject to change.



Powering Business Worldwide

UNLESS OTHERWISE SPECIFIED ALL DIMENSIONS IN MILLIMETRES.

DRAWN	SCALE	FILENAME:	A4
01.05.13	NTS		
TITLE SITE PLANNING GUIDE			
93E 80-120kVA - Internal MBS Models			
DRAWING NUMBER			REV
SITEPLAN_93E_80-120kVA-MBS			1