

Eaton® 9170+ UPS

3–18 kVA

User's Guide



Powering Business Worldwide

Requesting a Declaration of Conformity

Units that are labeled with a CE mark comply with the following harmonized standards and EU directives:

- Harmonized Standards: IEC 62040-1 and IEC 62040-2; IEC 60950 Third Edition
- EU Directives:
 - 73/23/EEC, Council Directive on equipment designed for use within certain voltage limits
 - 93/68/EEC, Amending Directive 73/23/EEC
 - 89/336/EEC, Council Directive relating to electromagnetic compatibility
 - 92/31/EEC, Amending Directive 89/336/EEC relating to EMC

The EC Declaration of Conformity is available upon request for products with a CE mark. For copies of the EC Declaration of Conformity, contact:

Eaton
Koskelontie 13
FIN-02920 Espoo
Finland
Phone: +358-9-452 661
Fax: +358-9-452 665 68

Eaton, Intelligent Power Manager, ePDU, and FERRUPS are registered trademarks and Predict*Pulse*, ConnectUPS, and BestDock are trademarks of Eaton or its subsidiaries and affiliates. Phillips is a registered trademark of Phillips Screw Company. Torx is a registered trademark of Textron, Inc. National Electrical Code and NEC are registered trademarks of National Fire Protection Association, Inc. All other trademarks are property of their respective companies.

©Copyright 2000–2015 Eaton, Raleigh, NC, USA. All rights reserved. No part of this document may be reproduced in any way without the express written approval of Eaton.

Class A EMC Statements

FCC Part 15

Note: This equipment has been tested and found to comply with the limits for a Class A digital device, pursuant to part 15 of the FCC Rules. These limits are designed to provide reasonable protection against harmful interference when the equipment is operated in a commercial environment. This equipment generates, uses, and can radiate radio frequency energy and, if not installed and used in accordance with the instruction manual, may cause harmful interference to radio communications. Operation of this equipment in a residential area is likely to cause harmful interference in which case the user will be required to correct the interference at his own expense.

ICES-003

This Class A Interference Causing Equipment meets all requirements of the Canadian Interference Causing Equipment Regulations ICES-003.

Cet appareil numerique de la classe A respecte toutes les exigences du Reglement sur le materiel brouilleur du Canada.

IEC 62040-2

Some configurations are classified under IEC 62040-2 as "C2 UPS for Unrestricted Sales Distribution."

VCCI Notice

この装置は、情報処理装置等電波障害自主規制協議会（VCCI）の基準に基づくクラスA情報技術装置です。この装置を家庭環境で使用すると電波妨害を引き起こすことがあります。この場合には使用者が適切な対策を講ずるよう要求されることがあります。

Special Symbols

The following are examples of symbols used on the UPS or accessories to alert you to important information:



RISK OF ELECTRIC SHOCK - Observe the warning associated with the risk of electric shock symbol.



CAUTION: REFER TO OPERATOR'S MANUAL - Refer to your operator's manual for additional information, such as important operating and maintenance instructions.



This symbol indicates that you should not discard the UPS or the UPS batteries in the trash. This product contains sealed, lead-acid batteries and must be disposed of properly. For more information, contact your local recycling/reuse or hazardous waste center.



This symbol indicates that you should not discard waste electrical or electronic equipment (WEEE) in the trash. For proper disposal, contact your local recycling/reuse or hazardous waste center.

Table of Contents

1	INTRODUCTION	1
	Safety Warnings	1
	Physical Features	3
2	INSTALLATION SETUP	7
	Equipment Clearances	7
	Location Requirements	7
	UPS Setup	8
	Three- and Six-Slot Cabinets	8
	Nine- and Twelve-Slot Cabinets	8
	Caster Cart Installation (Three- and Six-Slot Cabinets)	9
	Stabilizer Bracket Installation (Twelve-Slot Cabinet Only)	10
	Rack-Mount Installation (Three- and Six-Slot Cabinets)	11
	Floor Anchor Kit Installation	12
	Moving the Cabinets	13
3	UPS WITH BYPASS ELECTRICAL INSTALLATION	15
	Input Current Ratings	16
	Bypass Switches	17
	Bypass Switch Operation	17
	UPS Installation with an External Bypass Switch	19
	System Wiring Diagrams	25
4	UPS ELECTRICAL INSTALLATION	29
	Input Current Ratings	29
	UPS Electrical Installation	30
	System Wiring Diagrams	35
5	ISOLATED OUTPUT WIRING DIAGRAMS	39
	Neutral-to-Ground Bonding for Isolated Output	40
	System Wiring Diagrams	41
6	BATTERY CABINET INSTALLATION	45
7	UPS STARTUP	51
	Power and Battery Module Installation	51
	Startup for Plug-Receptacle Units	52
	Startup for Hardwired Units	54
	Initial Startup Parameters	56
8	OPERATION	59
	Turning the UPS On	60
	Removing Input Power	60
	Front Panel Display	61
	Using the Front Panel Display	61
	Parameters	62
	Changing Parameter Settings	63

Table of Contents

- Reading the Eaton 9170+ System Logs 63
 - Inverter Log..... 63
 - Alarm Log 64
- Battery Test..... 65
- Menu Map..... 65
- 9 COMMUNICATION 67**
 - Intelligent Power Manager 67
 - PredictPulse 67
 - Optional Interface Kits..... 67
 - Communication Slots 68
 - ConnectUPS Web/SNMP Card (BD Model) 68
 - Relay Interface Card (BestDock Model) 68
 - Dedicated Input Signals..... 68
 - DB-9 Communication Port..... 69
- 10 MAINTENANCE..... 71**
 - Routine Maintenance 71
 - Storage Temperature 71
 - External Bypass Switch (Make-Before-Break Only) Operation 71
 - Battery Replacement..... 72
 - Power Module Replacement..... 72
- 11 SPECIFICATIONS 75**
- 12 TROUBLESHOOTING..... 81**
 - Alarms 82
 - Service and Support 85
- 13 WARRANTY 87**
 - Two-Year Limited Warranty (US and Canada) 87
 - Load Protection Guarantee (US and Canada) 89

Chapter 1 Introduction

The Eaton® 9170+ uninterruptible power system (UPS) is a modular UPS that contains battery modules and power control modules (referred to as power modules). These modules plug into a rack cabinet structure containing additional control, communication, and display functions that enable integrated control of all power modules. The UPS is housed in a single cabinet, with extra battery capacity housed in auxiliary battery cabinets.

The pluggable power modules can be removed and replaced (hot-swapped) without powering the UPS down if the UPS has sufficient redundant capacity. Battery modules may also be hot-swapped for maintenance. Power control circuitry in the cabinet senses problems in power modules, and automatically transfers control and load to the remaining power modules.

All power modules share the load requirements equally. For example, three power modules are capable of supplying a total of 9 kVA. If a load requires only 4.5 kVA, each power module supplies 1.5 kVA to the output. If one power module is removed or for some reason fails, each of the two remaining power modules would supply half of the load, or 2.25 kVA. In other words, redundancy exists when the load can be supplied by less than all of the installed power modules.

The UPS can be configured with up to seven power and/or optional battery charger modules; its output is limited such that an excess number of power modules allow the failure of one or more modules without causing the UPS to lose any functionality.

To permit UPS removal from the power path while maintaining power to the loads, an external bypass switch is required. This switch is optional but recommended for system serviceability.

Safety Warnings

IMPORTANT SAFETY INSTRUCTIONS — SAVE THESE INSTRUCTIONS

This manual contains important instructions that you should follow during installation and maintenance of the UPS and batteries. Please read all instructions before operating the equipment and save this manual for future reference.

CAUTION

- Split-phase power modules (model ASY-0673) have brown labels on the front and produce two output voltages: 100/100 for 200, 110/110 for 220, 120/120 for 240, 120/120 for 208, or 127/127 for 220 Vac. Universal power modules (model ASY-0674) have black labels on the front and produce a single output voltage: 200, 208, 220, 230, or 240 Vac. DO NOT mix the two types of power modules in the same Eaton 9170+ cabinet.
 - Do NOT install more than seven power and/or optional battery charger modules in the system.
 - Battery modules to be used in the Eaton 9170+ system are model ASY-0529. Each battery module weighs 14 kg (30 lb). Use care in lifting and moving battery modules.
 - All input and output wiring must be copper and adequate to carrying currents as listed in Table 16 on page 76 and Table 17 on page 77.
 - Torque all bolts holding input and output power conductors to values specified in Table 2 on page 16.
 - The user is required to provide power input and output disconnect devices for the UPS. These must be within sight of the UPS and easily accessible. For a plug-receptacle unit, the plug serves as the power input disconnect device, which must also be readily accessible.
-

Consignes de Sécurité

CONSIGNES DE SÉCURITÉ IMPORTANTES — CONSERVER CES INSTRUCTIONS

Ce manuel comporte des instructions importantes que vous êtes invité à suivre lors de toute procédure d'installation et de maintenance des batteries et de l'onduleur. Veuillez consulter entièrement ces instructions avant de faire fonctionner l'équipement et conserver ce manuel afin de pouvoir vous y reporter ultérieurement.



ATTENTION!

- Les blocs de puissance à phase auxiliaire (modèle ASY-0673) sont dotés d'étiquettes marron sur le dessus et produisent deux tensions de sortie : 100/100 pour 200, 110/110 pour 220, 120/120 pour 240, 120/120 pour 208, ou 127/127 pour 220 Vca. Les blocs de puissance universels (modèle ASY-0674) sont dotés d'étiquettes noires sur le dessus et produisent une seule tension de sortie : 200, 208, 220, 230 ou 240 Vca. NE mélangez PAS les deux types de blocs de puissance dans le même module d'unité d'alimentation.
 - N'installez PAS plus de sept chargeurs de batteries optionnels et/ou de puissance dans le système.
 - Les modules de batterie à utiliser dans le système Eaton 9170+ correspondent au modèle ASY-0529. Chaque module de batterie pèse 14 kg (30 lb). Levez ou déplacez les modules de batterie avec soin.
 - Tous les câblages d'entrée et de sortie doivent être en cuivre et doivent prendre en charge les courants répertoriés dans les Table 16 et Table 17 des pages 76 et 77.
 - Couplez tous les boulons en maintenant les conducteurs de sortie sur les valeurs indiquées dans le Table 2 à la page 16.
 - L'utilisateur doit fournir des appareils de déconnexion de l'alimentation en entrée et en sortie pour l'onduleur. Ceux-ci doivent se trouver dans le périmètre de l'onduleur et être faciles d'accès. En ce qui concerne l'unité de prise, la prise sert d'appareil de déconnexion de l'alimentation en entrée, laquelle doit également être facile d'accès.
-

Advertencias de Seguridad

INSTRUCCIONES DE SEGURIDAD IMPORTANTES — GUARDE ESTAS INSTRUCCIONES

Este manual contiene instrucciones importantes que debe seguir durante la instalación y el mantenimiento del SIE y de las baterías. Por favor, lea todas las instrucciones antes de poner en funcionamiento el equipo y guarde este manual para referencia en el futuro.



PRECAUCIÓN

- Los módulos de potencia de fase dividida (modelo ASY-0673) portan etiquetas de color café en la parte delantera y producen dos voltajes de salida: 100/100 para 200, 110/110 para 220, 120/120 para 240, 120/120 para 208 ó 127/127 para 220 Vca. Los módulos de potencia universal (modelo ASY-0674) portan etiquetas negras en la parte delantera y producen un solo voltaje de salida: 200, 208, 220, 230 ó 240 Vca. NO combine los dos tipos de módulos de potencia en el mismo gabinete de la Unidad de distribución de alimentación.
- NO instale en los módulos de potencia del sistema más de siete módulos de potencia y/o de cargadores opcionales de baterías.

- Los módulos de baterías a utilizarse en el sistema Eaton 9170+ son del modelo ASY-0529. Cada módulo de batería pesa 14 kg (30 lb). Levante y mueva con cuidado los módulos de baterías.
- Todo el cableado de entrada y de salida debe ser de cobre y del tipo adecuado para transportar las corrientes detalladas en la Table 16 y en la Table 17, en las páginas 76 y 77.
- Apriete todos los pernos que sostengan los conductos de alimentación de entrada y de salida según los valores de torsión especificados en la Table 2, en la página 16.
- Se le solicita al usuario suministrar dispositivos de desconexión de entrada y salida de alimentación para el SIE. Éstos deben estar a la vista del SIE y ser de fácil acceso. Para una unidad con receptáculo de conexión, el conector funge como dispositivo de desconexión de entrada de alimentación, el cual también debe estar fácilmente accesible.

Physical Features

The Eaton 9170+ UPS is available in four cabinet sizes. Figure 1 through Figure 6 show the 3-slot and 9-slot configurations and identify basic Eaton 9170+ system features. Six-slot and 12-slot cabinets are also available; external battery cabinets are available in 6-, 9-, and 12-slot sizes.

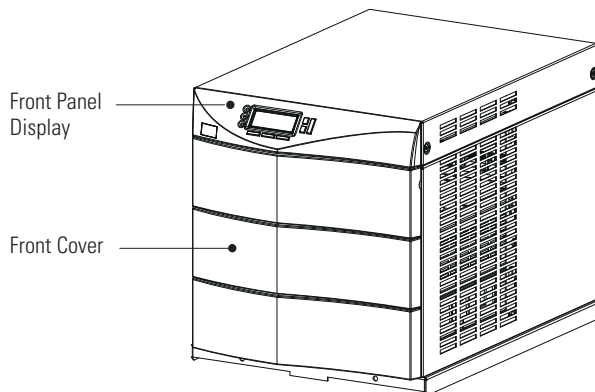

Figure 1. Three-Slot Cabinet (Front View)

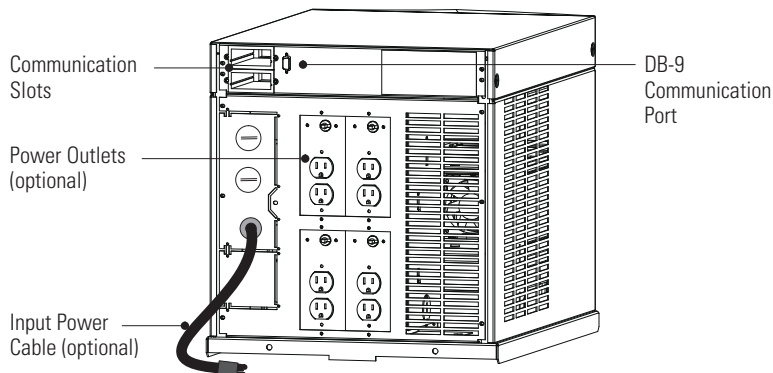

Figure 2. Three-Slot Cabinet (Rear View)

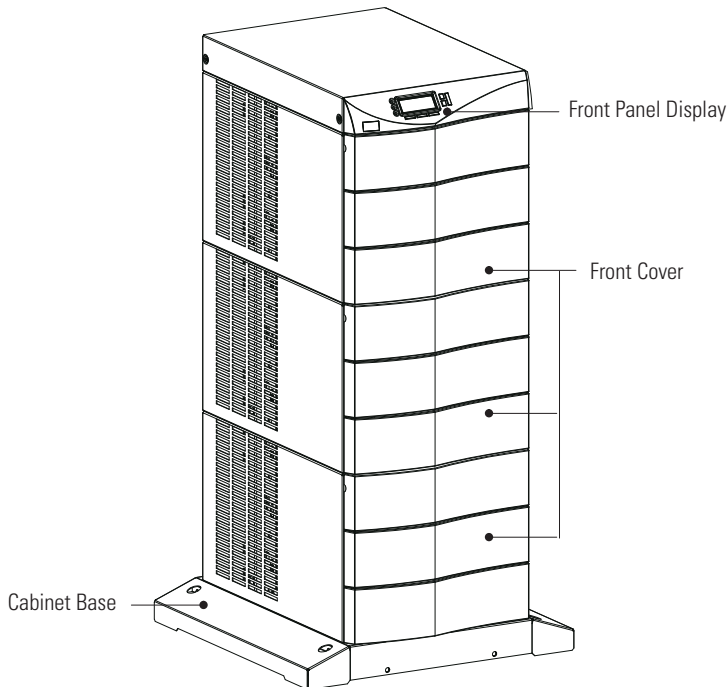

Figure 3. Nine-Slot Cabinet (Front View)

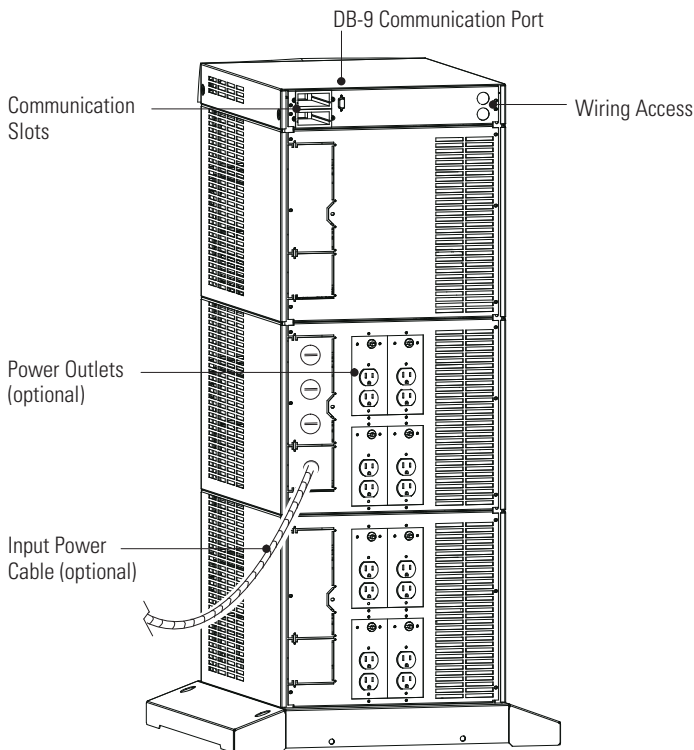

Figure 4. Nine-Slot Cabinet (Rear View)

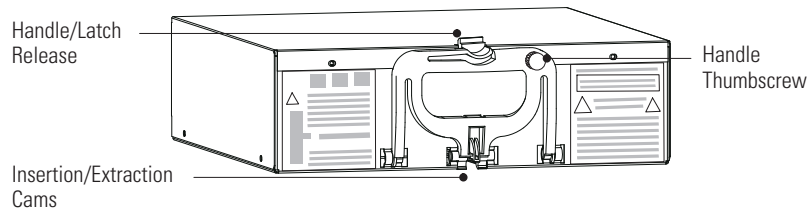

Figure 5. Power Module (ASY-0673 and ASY-0674)

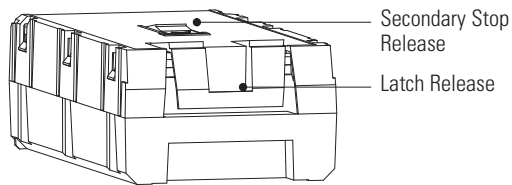

Figure 6. Battery Module (ASY-0529)

Chapter 2 Installation Setup

This chapter explains how to set up and install the Eaton 9170+ cabinets:

- Setup, including clearances and location requirements
- Caster cart installation (for 3- and 6-slot cabinets)
- Stabilizer bracket installation (for 12-slot cabinets with non-isolated output)
- Rack-mount installation (for 3- and 6-slot cabinets)
- Floor anchor kit installation
- Moving the cabinets

Equipment Clearances

All cabinet sizes require the following clearances to allow for servicing and adequate ventilation:

- Sides: 15.2 cm (6")
- Top and back: 30.5 cm (12")
- Front: 91.5 cm (36")

If flexible conduit connects the UPS to the service input and load distribution panels, you may be able to gain access for servicing by moving the UPS. If this is the case, you must still leave 30.5 cm (12") clearance at the back and 15.2 cm (6") at the sides of the UPS for ventilation.



NOTE Do not block the ventilation holes on each side and the back of the cabinet.

Nine- and 12-slot external battery cabinets may be installed with bases tight against the UPS cabinet base and against each other. Six-slot cabinets require 15.2 cm (6") of separation.

Location Requirements

Install the Eaton 9170+ UPS as close as possible to the equipment or the load distribution panel it will protect. If this distance is more than 7.6m (25 ft), transient noise can reappear in the electrical distribution system.

If a separate external battery cabinet is installed, the battery cabinets must be adjacent to the Eaton 9170+ UPS. If the batteries will be farther from the cabinet than the standard cables allow, contact your service representative or your local distributor for assistance.

UPS Setup

The Eaton 9170+ UPS is shipped in a carton on a shipping pallet. Power and battery modules are shipped in separate boxes on another pallet. Three-slot cabinets and modules are shipped on one pallet. Refer to the unpacking instruction sheet (LTS-1724) packed inside the UPS shipping carton.

 **NOTE** Verify that all Eaton 9170+ UPS power modules are the proper type for the UPS cabinet: Split-phase power modules have brown labels; universal (single-phase) power modules have black labels. Do not mix brown and black modules in the same UPS cabinet.

Three- and Six-Slot Cabinets

 **NOTE** Do not attempt to lift the cabinet by the module shelves or other convenient edges or covers.

To set up 3- or 6-slot cabinets:

1. Place the cabinet in its intended operating location.
2. If an optional caster cart is included for cabinet mobility, see “Caster Cart Installation (Three- and Six-Slot Cabinets)” on page 9 to mount the cabinet on the cart and stabilize it using the cart foot pads.
3. Cut the lifting straps or slip them off the cabinet base tabs.
4. If an optional floor anchor kit is included for extra stability, see “Floor Anchor Kit Installation” on page 12 to install the floor anchor brackets.
5. If installing the 3- or 6-slot cabinet in a rack, see “Rack-Mount Installation (Three- and Six-Slot Cabinets)” on page 11 to install the cabinet in the rack.
6. If you are installing an external battery cabinet, continue to “Battery Cabinet Installation” on page 45.
If you do not have an external battery cabinet, continue to “UPS Startup” on page 51 for plug-receptacle units. For hardwired units, continue to “UPS with Bypass Electrical Installation” on page 15 or “UPS Electrical Installation” on page 29.

Nine- and Twelve-Slot Cabinets

 **CAUTION**

Do NOT lower the casters or attempt to move the cabinet with the power or battery modules installed.

To set up 9- or 12-slot cabinets:

 **NOTE** If you are installing a 12-slot Eaton 9170+ UPS with non-isolated output, do not follow this procedure. Proceed to “Stabilizer Bracket Installation (Twelve-Slot Cabinet Only)” on page 10.

1. Lower the four cabinet casters (one at each corner of the cabinet base) by using a 1/2" hex-style socket wrench to turn each bolt clockwise.
2. With all casters fully extended, carefully roll the cabinet down the ramp to its intended operating location.

3. Stabilize the cabinet in its operating location by turning the four caster bolts counter-clockwise until the cabinet rests on the floor. Place a plastic cap into each bolt access hole.



NOTE If the floor is uneven and the cabinet is tilted or unstable, you may need to place a thin steel plate under a corner. Do not use the caster bolts to level the cabinet.

4. If an optional floor anchor kit is included for extra stability, see “Floor Anchor Kit Installation” on page 12 to install the floor anchor brackets.
5. If installing the 9- or 12-slot cabinet in a rack, follow the installation instructions with the 9- and 12-slot rack-mount kit.
6. If you are installing an external battery cabinet, continue to “Battery Cabinet Installation” on page 45.

If you do not have an external battery cabinet, continue to “UPS Startup” on page 51 for plug-receptacle units. For hardwired units, continue to “UPS with Bypass Electrical Installation” on page 15 or “UPS Electrical Installation” on page 29.

Caster Cart Installation (Three- and Six-Slot Cabinets)

An optional caster cart (ASY-0527) is available for 3- and 6-slot cabinets for increased mobility of the UPS (see Figure 7).



NOTE The UPS cabinet is heavy (see Table 20 on page 79). This procedure requires two people to lift and position the cabinet onto the caster cart. Lift the cabinet using four lifting straps shipped with the cabinet. Do not attempt to lift the cabinet by the module shelves or other convenient edges or covers.

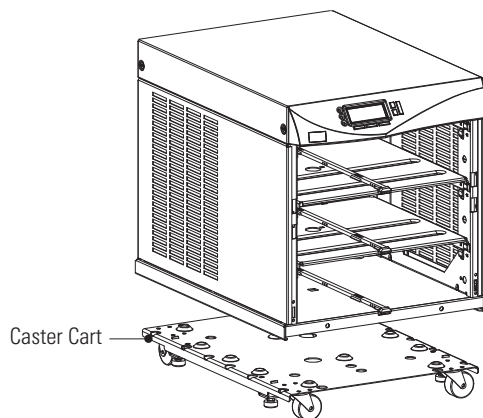

Figure 7. Three-Slot Cabinet Being Lowered onto Caster Cart

To install the caster cart:

1. Place the caster cart (shipped separately from the UPS cabinet) under the cabinet before installing power and battery modules and before making connections to the intended power source.

The cart requires no bolts or other hardware to fasten it to the UPS cabinet. It is shaped to fit securely under the cabinet, ensuring proper alignment after placing the cabinet on the cart.

2. Four foot pads under the cart keep the cart from rolling when it is in its intended location. Turn each threaded foot to lower it to the floor. When the foot is tight against the floor, turn the locknut on the threaded foot up tight against the bottom of the cart to keep the foot from rotating.
3. If leveling of the UPS is required, use the foot pads to raise a side or corner before locking them with their locknuts.

Stabilizer Bracket Installation (Twelve-Slot Cabinet Only)

The 12-slot Eaton 9170+ UPS cabinet with non-isolated output is shipped with two stabilizer brackets. These brackets must be attached to the wall or the floor behind the UPS cabinet. Under all module-loading conditions, they act as a protective stop to prevent the cabinet from falling forward if it is unintentionally pushed away from the wall.

Each bracket has holes that enable it to be attached by screws to either the wall or the floor (or both) behind the intended cabinet installation (see Figure 8). The stabilizer brackets are not attached to the cabinet base itself.

To install the stabilizer brackets:

1. Select the location for the brackets, approximately 30–41 cm (12–16") apart, at the floor/wall intersection behind the intended cabinet location.
2. Using the proper type of customer-supplied screws for the intended mounting surface, attach each bracket as shown in Figure 8. All screws must be driven into structural material such as wall studs.
3. Roll the UPS cabinet to its intended location. Position the rear section of the cabinet base under the open ends of the stabilizer brackets as far as the cabinet will go.
4. Turn all four caster bolts counter-clockwise until the cabinet rests on the floor. Place a plastic cap into each bolt access hole.



NOTE

If the floor is uneven and the cabinet is tilted or unstable, you may need to place a thin steel plate under a corner. Do not use the caster bolts to level the cabinet.

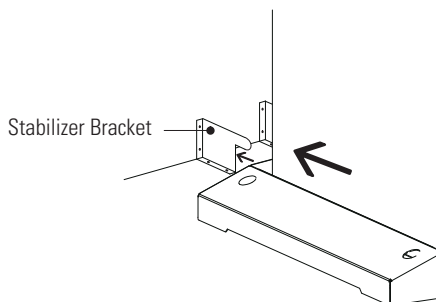

Figure 8. Stabilizer Bracket Installation

Rack-Mount Installation (Three- and Six-Slot Cabinets)

NOTE 1 For 9- and 12-slot cabinets, follow the installation instructions with the 9- and 12-slot rack-mount kit.

NOTE 2 The UPS cabinet is heavy (see Table 20 on page 79). This procedure requires two people to lift and position the cabinet into the equipment rack. Install the cabinet in the rack before installing power and battery modules and before making connections to the intended power source.

The 3- and 6-slot UPS cabinets may be installed in an EIA-standard 48.3 cm (19") equipment rack. An optional rack-mounting kit (ASY-0547), containing brackets and required hardware, is available.

For each 3-slot section, use the following mounting procedure to convert the UPS cabinet and install it in the equipment rack:

1. Remove the four screws (two on either side) securing the top cover of the UPS cabinet. Carefully lift the cover straight up and off to avoid stressing the front panel display. Set the cover aside.
2. Remove the two cabinet side covers (four covers in 6-slot cabinets) by lifting the top edge. No other hardware must be detached. Store or discard the side covers.
3. Carefully replace the UPS cabinet top cover and secure with the four screws removed in Step 1. Position the cover lip to fit behind the front panel display.
4. Install three metal clip nuts onto each side flange (six clip nuts on 6-slot cabinets) along the front of the UPS cabinet (see Figure 9).

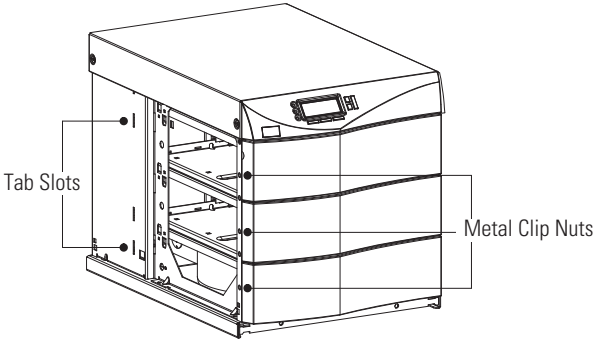

Figure 9. Metal Clip Nut and Tab Slot Locations

5. Install a rack-mount ear (two for 6-slot cabinets) on each side of the UPS cabinet (see Figure 10). Insert the two offset tabs on the rear edge of the ear into the matching tab slots on the cabinet side frame (see Figure 9). Pivot the ear forward until it is flush against the UPS cabinet side frame. Using three 1/4-20 1/2" Phillips®-head bolts, screw the bolts into the metal clip nuts installed in Step 4.

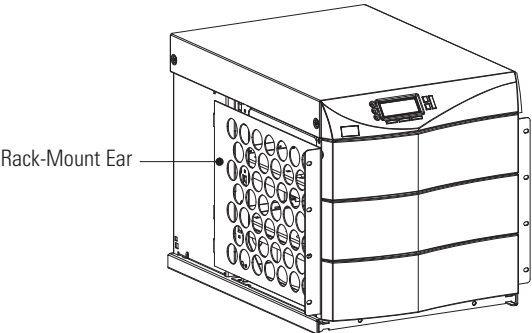

Figure 10. Rack-Mount Ear Installed

6. Select the position for the UPS in the equipment rack.
7. Select the proper holes in the rail that position the UPS at the desired location in the rack.
8. With one person lifting each side of the UPS cabinet, carefully slide the UPS into the equipment rack until the rack-mount ears of the cabinet are flush with the front vertical rails of the rack. Verify that the holes in the ears align with the holes in the rack.
9. Secure the UPS in the rack using eight 10-32 1/2" Torx® screws (16 for 6-slot cabinets) or other appropriate customer-specified screws.

Floor Anchor Kit Installation

An optional floor anchor kit (ASY-0548) is available for all sizes of the Eaton 9170+ UPS. The kit helps to stabilize the UPS or battery cabinet in the event of accidental bumps or small floor movements. Any testing to specific seismic requirements is the responsibility of the customer.

The floor anchor brackets, shipped separately from the UPS and battery cabinet, should be attached inside the lower front and rear edges of the cabinet before installing power and battery modules and before making connections to the intended power source.

Use mounting hardware supplied with the floor anchor kit to attach the brackets to the UPS or external battery cabinet (see Figure 11). The customer is responsible for specifying and supplying floor mounting bolts.

Mounting Centers for 8 mm (5/16") Floor Bolts	
Dimension (see Figure 11)	Measurement
A	36.8 cm (14.5")
B (3- and 6-slot cabinets)	76.8 cm (30.25")
B (9- and 12-slot cabinets)	87 cm (34.25")

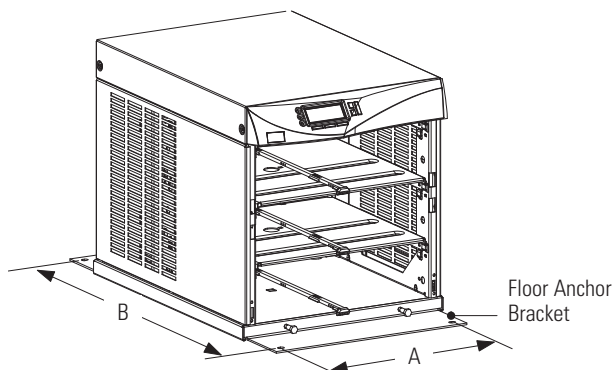

Figure 11. Floor Anchor Brackets Bolted to UPS Cabinet

Moving the Cabinets

 **CAUTION**

Do NOT attempt to raise the cabinet with the power or battery modules installed.

The Eaton 9170+ UPS and the battery cabinet are very heavy with power and battery modules installed. Before moving the cabinets, remove the power and battery modules. Move the modules separately from the cabinets.

The 3- and 6-slot cabinets may be ordered with a caster cart to enable moving the cabinet. “Caster Cart Installation (Three- and Six-Slot Cabinets)” on page 9 describes how to set the four foot pads on this cart to keep the cabinet from rolling when properly positioned.

The 9- and 12-slot cabinets have casters built into the cabinet base. To raise the cabinet before rolling it on its casters:

1. Verify that the cabinet contains no power or battery modules.
2. **For 12-slot cabinets with non-isolated output only.** Slide the cabinet base out from under the stabilizer brackets in the rear section of the cabinet base.

Remove the stabilizer brackets from the floor/wall. Follow the instructions in “Stabilizer Bracket Installation (Twelve-Slot Cabinet Only)” on page 10 to reinstall the stabilizer brackets in the new location.

3. Locate the four plastic caps covering the caster bolts. They are at the corners of the cabinet base.
4. Pry the caps out of the bolt access holes.
5. Use a 1/2" hex-style socket wrench to turn each of the four bolts clockwise. Doing so lowers the casters to allow the cabinet to roll on the casters.
6. After rolling the cabinet to its intended position, turn all four caster bolts counter-clockwise until the cabinet rests on the floor. Place a plastic cap into each bolt access hole.

**NOTE**

If the floor is uneven and the cabinet is tilted or unstable, you may need to place a thin steel plate under a corner. Do not use the caster bolts to level the cabinet.

7. After properly positioning and leveling the cabinet, insert power and battery modules into the cabinet as described in “Power and Battery Module Installation” on page 51.

Chapter 3 UPS with Bypass Electrical Installation

NOTE If you have a plug-receptacle unit, continue to “Battery Cabinet Installation” on page 45 for installing optional battery cabinets, or to “UPS Startup” on page 51.

WARNING

Risk of electrical shock. Only qualified service personnel (such as a licensed electrician) should perform the electrical installation.

The Eaton 9170+ UPS input power may be hardwired through conduit to either a main power source circuit breaker or to an optional external bypass switch. For hardwired installations, it is recommended that you install an Eaton bypass switch to enable power transfer during maintenance or UPS downtime. If a bypass switch is used, both UPS input and UPS output must be hardwired — through separate conduits — to the bypass switch, as shown in Figure 12.

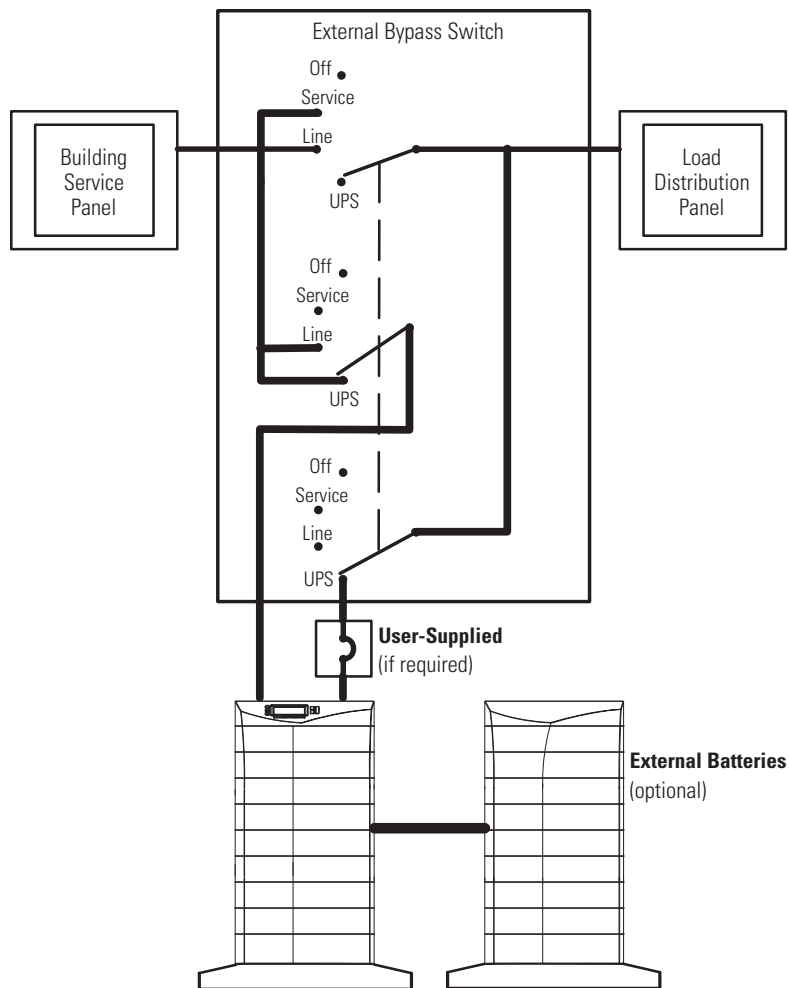

Figure 12. Typical Installation with a Bypass Switch

Input Current Ratings

Table 1 contains the required circuit breaker ratings for hardwired installations. Circuit breaker ratings for units having an input line cord are determined by the current capacity of the line cord.

Table 1. Required Input Circuit Breaker Sizes (200–240 Vac, 50/60 Hz)

UPS Capacity	Input Circuit Breaker Rating
3 kVA	25A
6 kVA	40A
9 kVA	60A
12 kVA	80A
15 kVA	100A
18 kVA	125A

NOTE 1 If you are installing an optional battery charger module, refer to that user's guide for the proper input circuit breaker sizes and ratings.



NOTE 2 To accommodate the feature of easy system expandability, it is recommended that initial installation of the Eaton 9170+ UPS contains wiring to support the maximum capacity of the UPS cabinet: 3 kVA for 3-slot cabinets; 9 kVA for 6-slot cabinets; 18 kVA for 9- and 12-slot cabinets.

See Table 2 for recommended conductor sizes to wire the input circuit breakers.

Table 2. Recommended Wire Sizes

Input Circuit Breaker Size	75°C Copper Wire Size	Conductor Screw Torque
25A	5.3 mm ² (10 AWG)	4.0 Nm (35 lb in)
40A	8.4 mm ² (8 AWG)	4.5 Nm (40 lb in)
60A	21.2 mm ² (4 AWG)	5.1 Nm (45 lb in)
80A	26.7 mm ² (3 AWG)	6.6 Nm (50 lb in)
100A	33.6 mm ² (2 AWG)	6.6 Nm (50 lb in)
125A	42.1 mm ² (1 AWG)	6.6 Nm (50 lb in)



IMPORTANT

FOR U.S. INSTALLATIONS, READ THIS IMPORTANT NOTE

- Table 2 lists the mm² and AWG wire size for each circuit breaker size shown on the wiring diagrams. The minimum recommended circuit breaker sizes for each model and voltage application are listed on the wiring diagrams.
- Conductor sizes shall be no smaller than the 75°C wire size based on the ampacities given in Table 310–16 of the National Electrical Code® (NEC®), ANSI/NFPA 70-1999, and article 220. All circuit conductors, including the neutral conductor, must be the same size (ampacity) wire. Code may require a larger AWG size than shown in this table because of temperature, number of conductors in the conduit, or long service runs. Follow local code requirements.

Bypass Switches

Bypass switches are available in two types: Make-Before-Break (MBB) and Break-Before-Make (BBM).

An MBB switch makes a new connection before it breaks the original connection. For example, if you turn an MBB switch from UPS to LINE, the bypass switch connects the load to AC input power before disconnecting the load from UPS output power. (As noted in Figure 38 on page 42, MBB switches may not be used in certain system configurations.)

A BBM switch breaks the original connection before it makes a new one. If you turn a BBM switch from UPS to LINE, the switch disconnects the load from UPS output power before connecting the load to AC input power.

The bypass switch has four positions as described in Table 3.



NOTE In the UPS or LINE position, AC input power is still connected to the input terminals inside the UPS.

Table 3. Bypass Switch Positions

Switch Position	Description
LINE	Connects the load directly to AC input power and disconnects UPS output. AC input power is still connected to the UPS input.
OFF	Disconnects the load from the UPS output power and AC input power, as well as AC input power to the UPS input.
UPS	Connects the UPS output to the load.
SERVICE	Like the LINE position, SERVICE connects the load directly to AC input power and disconnects UPS output. However, because SERVICE also disconnects AC input from the UPS, this is the appropriate position for UPS maintenance or repair.

Bypass Switch Operation

The bypass switch consists of a load position handle and a red button (see Figure 13 on page 19).

The red button:

- Sends an electrical signal to the UPS to switch to the internal Bypass mode (if it is not already operating in that mode).
- Operates a mechanical interlock, to prevent the switch from being turned without first signaling the UPS.

For MBB switches, you must press the red button before you can turn the load position handle.

When the red button is pressed, the UPS front panel displays “Manual Bypass.” To move the MBB switch handle from one position to another, the red button must be pressed WHILE the handle is being rotated. Otherwise, the switch will be damaged.

After turning the load position handle to the UPS position and releasing the red button, the Eaton 9170+ UPS remains in Bypass mode. For proper operation, return the UPS to Auto mode using the following procedure.

NOTE 1 If the UPS remains in Manual Bypass mode and incoming AC power is lost, the load is automatically dropped. The UPS must be in Auto mode to provide battery backup power.



NOTE 2 If you have any questions or problems with the bypass operation, call the **Help Desk** at one of the telephone numbers on page 85 and ask for a UPS technical representative.

1. Press the menu button on the front panel display. The System Status Menu displays.
2. Press the ▼ button until the System Control menu displays.
3. Press the ← button. Mode Preference displays.
4. Press the ← button to access Mode Preference. The Enter Password screen automatically opens.
5. Enter the appropriate password (0377 is the default), then press the ← button.
6. Press the ← button again and press the ▼ button until you see Auto.
7. Press the ← button and listen for a click.
8. Press ESC twice to return to the System Status Menu. The UPS is now in Auto mode.



NOTE To disconnect AC input power during maintenance or service, turn the bypass switch to the SERVICE position.

Table 4 shows the bypass switch models available for the Eaton 9170+ UPS.

Table 4. Bypass Switch Specifications

Bypass Switch Models			See Figure 13					Weight
BBM	MBB	Rating, Continuous	Height (A)	Width (B)	Depth (C)	Mounting Centers (D) (E)		
BPE12BBM1A	BPE12MBB1A	40A/300 Vac (CSA) 50A/300 Vac (UL,TÜV)	53.4 cm (21.0")	35.6 cm (14.0")	17.2 cm (6.8")	28.0 cm (11.0")	50.8 cm (20.0")	12.3 kg (27 lb)
BPE14BBM1A	BPE14MBB1A	80A/300 Vac	53.4 cm (21.0")	35.6 cm (14.0")	17.2 cm (6.8")	28.0 cm (11.0")	50.8 cm (20.0")	14.1 kg (31 lb)
BPE20BBM1A	BPE20MBB1A	125A/300 Vac	53.4 cm (21.0")	35.6 cm (14.0")	17.2 cm (6.8")	28.0 cm (11.0")	50.8 cm (20.0")	15.9 kg (35 lb)

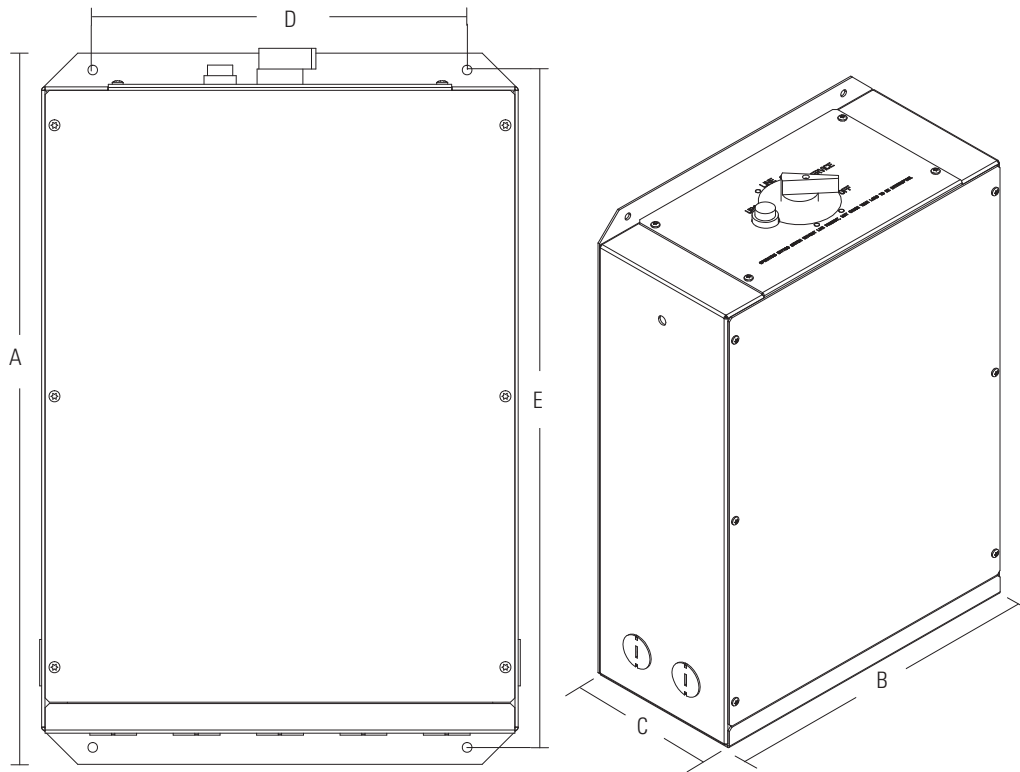

Figure 13. Bypass Switch Dimensions

UPS Installation with an External Bypass Switch

⚠ WARNING

Only qualified service personnel (such as a licensed electrician) should perform the electrical installation. Risk of electrical shock.

⚠ CAUTION

To prevent electrical shock or damage to the equipment, verify that the Eaton 9170+ UPS is OFF before you remove the entrance panel. The circuit breaker or disconnect switch must also be off at the AC input service panel. Also, turn OFF the AC disconnect and bypass switches before you connect any wires to the bypass switch terminal strip.

To install the UPS with an external bypass switch:

1. Mount the bypass switch within sight of the UPS. If you do not have an Eaton bypass switch or the fuse box or panel is out of sight, you must install a separate disconnect switch next to the UPS.
The bypass switch should be mounted securely to a sturdy surface. You may need to turn the cabinet 90 degrees (on its side) to enable operator access to the switch handle.
2. Remove the six screws in the bypass switch front cover and remove the cover. Remove any packing material inside the bypass switch.
3. Remove knockouts in the bottom of the bypass switch for AC Line Input, AC to UPS Input, AC from UPS Output, and AC to the UPS load.

4. Unscrew and remove the rear cover(s) of the UPS (top cover on 3- or 6-slot; top two covers on 9- or 12-slot). See Figure 14.

The entrance panel contains knockout openings for entrance and exit conduits and for conduit to an optional external battery cabinet. The entrance panel is located on the top 3-slot section for 3- and 6-slot cabinets; on the second section for 9- and 12-slot cabinets as shown in Figure 14.

Wiring for optional emergency power-off (EPO) and bypass input signals passes through the opening at the top back of the cabinet. Wiring for an optional generator input signal must pass through a separate opening. Installing this wiring is described in Steps 14 and 15 on page 24.

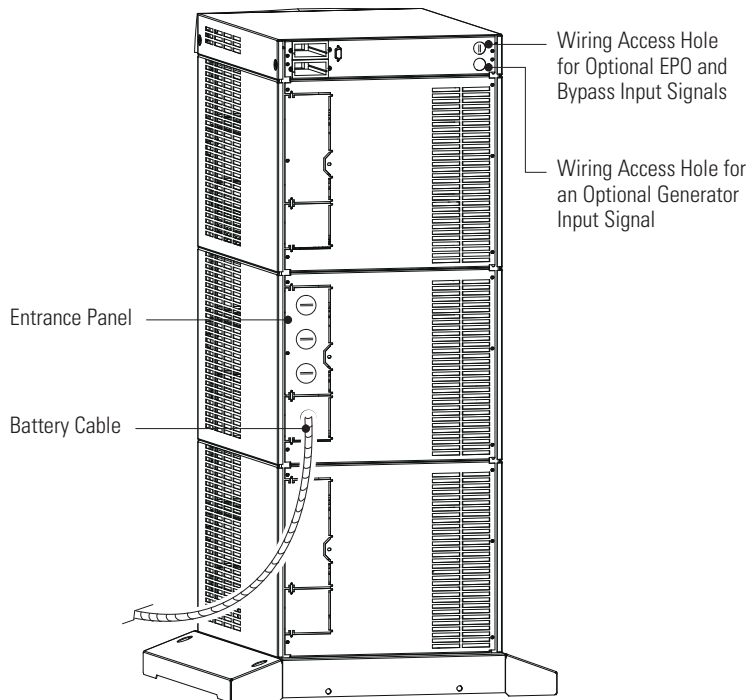

Figure 14. UPS Power Entrance Panel (Nine-Slot Cabinet Shown)

5. Remove the knockouts in the entrance panel for AC input and AC output wiring.

6. Install the conduit adapters. AC input and AC output conductors must be run through separate conduits. UPS output circuits must be installed in dedicated conduit systems and not shared with other electrical circuits.

Figure 15 shows input and output wiring terminals inside the Eaton 9170+ UPS cabinet.

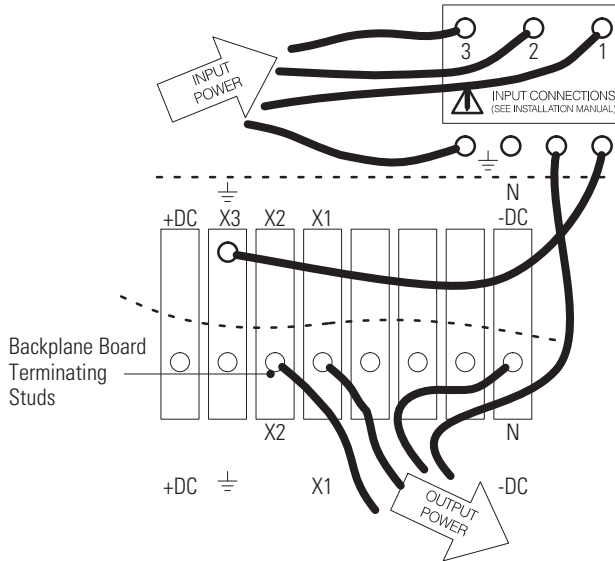

Figure 15. UPS Input and Output Terminals

7. Find the terminal strip inside the bypass switch cabinet. Using the label on the back of the bypass switch access cover and the proper installation wiring diagram, make the terminal strip connections and tighten all connections as specified in Table 2 on page 16. Use copper wire that is the appropriate size for the current draw.

Figure 16 shows a sample label.

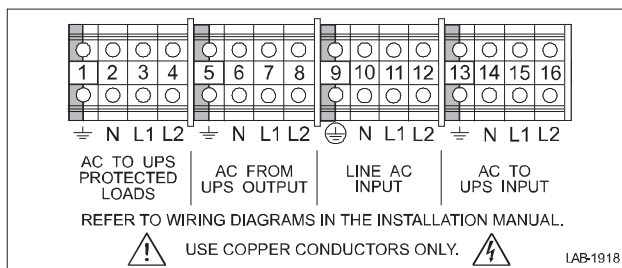

Figure 16. Bypass Switch Wiring Label

8. After installing bypass switch wiring, torque the screws holding all input and output power conductors to the values specified in Table 2 on page 16.

- Wire the UPS for the proper input voltage as shown in Figure 17.

Split-phase power modules (model ASY-0673, with brown labels on the front) are capable of supplying two output voltages: 100/100 for 200, 110/110 for 220, 120/120 for 240, 120/120 for 208, or 127/127 for 220 Vac, as selected through the front panel display. These modules produce two output voltages, typically required in North America, South America, and Japan.

Universal power modules (model ASY-0674, with black labels on the front) are capable of supplying a single-phase output voltage: 200, 208, 220, 230, or 240 Vac, as selected through the front panel display. These modules produce a single output voltage, typically required in Europe, the Middle East, Asia, and Africa.

⚠ CAUTION

Confirm that the UPS is wired for the proper input voltage as shown in Figure 17, and that the proper power modules (either split-phase or universal) are installed to produce the desired output voltage. Do not mix the two types of power modules in the same UPS cabinet.

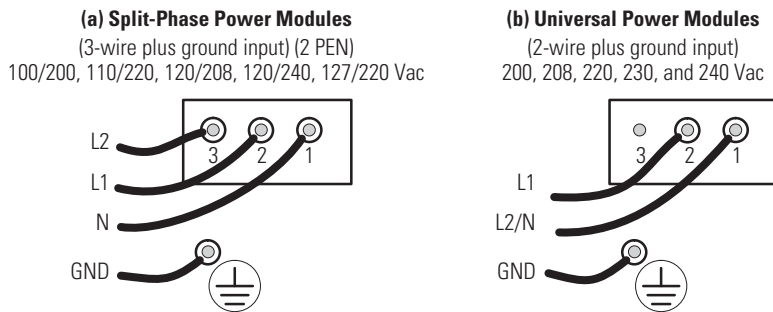

Figure 17. UPS Input Wiring

- For isolated output only.** See “Isolated Output Wiring Diagrams” on page 39 to complete the wiring for isolated output.
- See the wiring diagrams beginning on page 25 for output configurations for various voltages and isolation options. Make UPS output connections on the backplane board terminating studs. Compression lugs (supplied in the accessory kit) may be installed on the proper terminating studs. Wires may also be terminated with ring terminals, which are attached to the output terminating studs.

Figure 18 and Figure 19 describe output wiring configurations for various output voltages. You must also set the operating menu 4 2 4 for the required output voltage as shown in the wiring configuration drawings.

NOTE 1 For Eaton 9170+ UPS models with low-voltage hardwire output, it is recommended to divide the total load as equally as possible between X1 and X2, as shown in Figure 18.



NOTE 2 Failure to balance the loads may cause an overload alarm even if the full capacity of the UPS has not been reached.

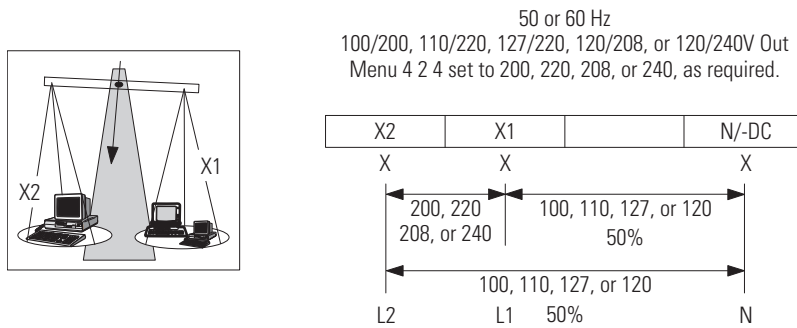

Figure 18. Split-Phase Power Modules with Non-Isolated Output

NOTE The factory-default wiring for all high-voltage receptacles in a chassis without a power cord is 3-wire plus ground input. If you have a universal power module (ASY-0674), all receptacles **MUST** be re-wired for a 2-wire plus ground input configuration as shown in Figure 19.

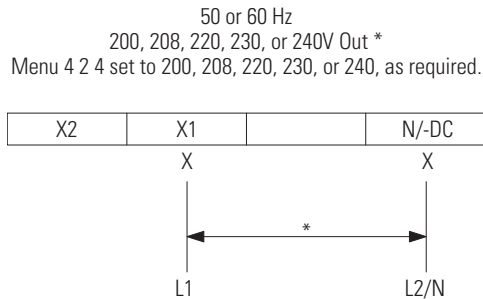

Figure 19. Universal Power Modules with Non-Isolated Output

12. Unscrew and remove the top rear cover of the cabinet and locate the terminal block.
13. If the bypass switch is an MBB style, notice the cable routed out of the left side of the bypass switch cabinet. Connect the red and black pair of wires (normally open) in this cable to terminals 3 and 4 as shown in Figure 20. (Do not connect the white and black pair of wires in this cable.)

CAUTION

EPO and external bypass circuits are not isolated from line voltage, and wiring must be installed according to local codes using conduit or suitable primary supply cables.

The Generator On signal is isolated from line voltage and can be treated as NEC Class 2 wiring.

Use 14–20 AWG, 600V wire (UL) or 14–26 AWG, 300V wire (CSA) for all input control signals.

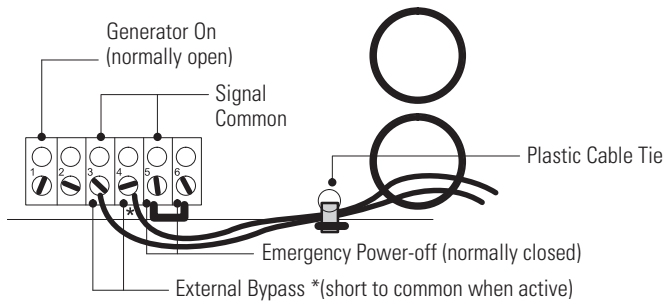

Figure 20. Input Control Signal Wiring (for MBB Bypass Switch)

14. If any external hardwired control signals are required (EPO or Generator On), connect the wiring as shown in Figure 21.

⚠ CAUTION

EPO and external bypass circuits are not isolated from line voltage, and wiring must be installed according to local codes using conduit or suitable primary supply cables.

The Generator On signal is isolated from line voltage and can be treated as NEC Class 2 wiring.

Use 14–20 AWG, 600V wire (UL) or 14–26 AWG, 300V wire (CSA) for all input control signals.

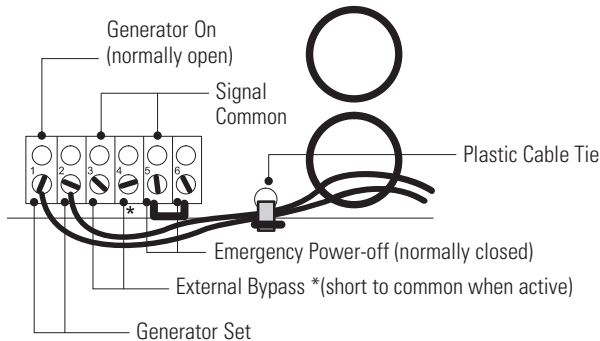

Figure 21. Input Control Signal Wiring (for External Controls)

15. Place the signal wires through the proper conduit or grommet above the terminal block and attach to appropriate terminals. Secure each connection by torquing terminal screws to a maximum 0.4 Nm (3.5 lb in). Provide strain relief for cables by installing plastic cable ties.

NOTE Do not strain relieve EPO or external bypass wiring with the same cable tie used for Generator On wires.

16. Remove the jumper between terminals 5 and 6 only if you are wiring from an EPO switch. (See “Changing Parameter Settings” on page 63 for information about accessing menu 4 3 2 to view or change the EPO switch type.)
17. When all connections have been made and checked, reinstall the bypass switch front cover and UPS cabinet rear covers using the original screws.

System Wiring Diagrams

Select wiring diagrams from Table 5 based upon the installation voltage.

Table 5. UPS with Bypass Wiring Diagrams for Non-Isolated Output

UPS Input Voltage	UPS Output Voltage	Output Wires	Wiring Diagrams		
			Input	Output	System
100/200	100/200	L1, L2, N*	Figure 17a on page 22	Figure 18 on page 23	Figure 22 on page 26
110/220	110/220				
120/208	120/208				
120/240	120/240				
127/220	127/220				
200	200	L1 – L2	Figure 17b on page 22	Figure 19 on page 23	Figure 23 on page 26
208	208				
220	220				
230	230				
240	240				
220	220	L1 – N	Figure 17b on page 22	Figure 19 on page 23	Figure 24 on page 27
230	230				
240	240				

* Split-phase power modules required.

The following notes are referenced in the non-isolated system wiring diagrams (Figure 22 through Figure 24).

NOTE 1 **The customer must provide input overcurrent protection.** See NEC Section 240-21 or local requirements. See Table 1 on page 16 for circuit breaker ratings to size the protection device according to local code requirements.

NOTE 2 The UPS bypass switch must be installed within sight of the UPS. To properly install, complete the voltage and phase check procedure in “Startup for Hardwired Units” on page 54. The wires coming from the side of the switch must be connected as described in n Step 13 on page 23.

NOTE 3 **The customer must size the AC circuit conductors.** All AC circuit conductors, including the neutral conductor, must be the same size (ampacity), have the same rating (75°C) copper wire, and be sized according to the input circuit breaker. See Table 2 on page 16 for recommended wire sizes. The UPS input and output conductors must be run through separate conduits.



NOTE 4 **The customer must provide output overcurrent protection.** See NEC Section 240-21 or local requirements. See Table 16 on page 76 and Table 17 on page 77 for maximum output overcurrent protection device ratings.

NOTE 5 See “Equipment Clearances” on page 7 for installation and service clearances before installing the UPS. Use flexible conduit on the UPS or the external battery cabinet if either must be moved.

NOTE 6 External UPS battery cabinets are optional. See “Battery Cabinet Installation” on page 45 for installation instructions.

NOTE 7 UPS output circuits shall be installed in dedicated conduit systems and not shared with other electrical circuits.

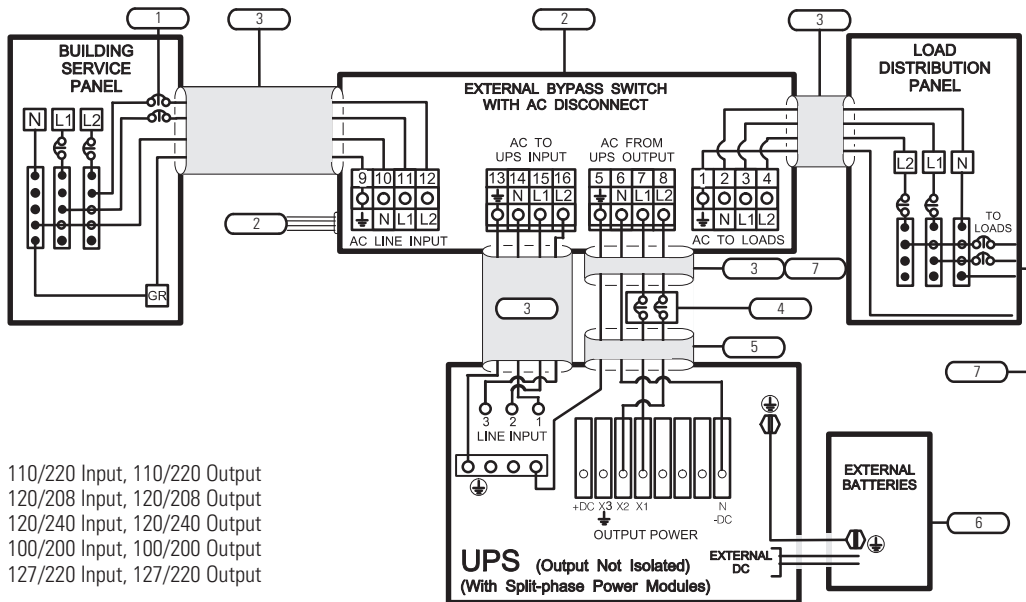

Figure 22. External Bypass Switch (L1, L2, N), Non-Isolated Output, Split-Phase Power Modules

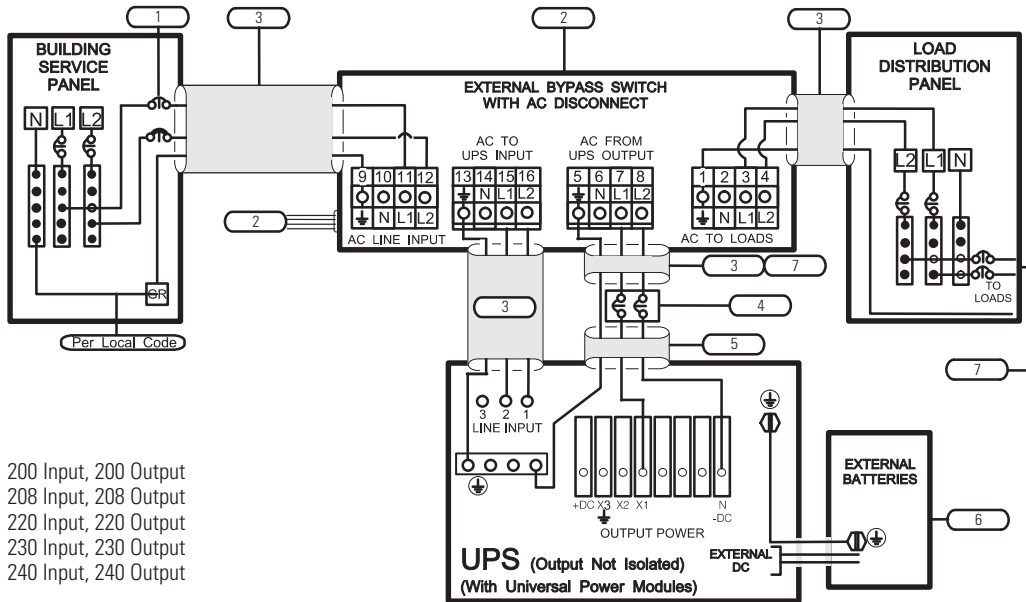
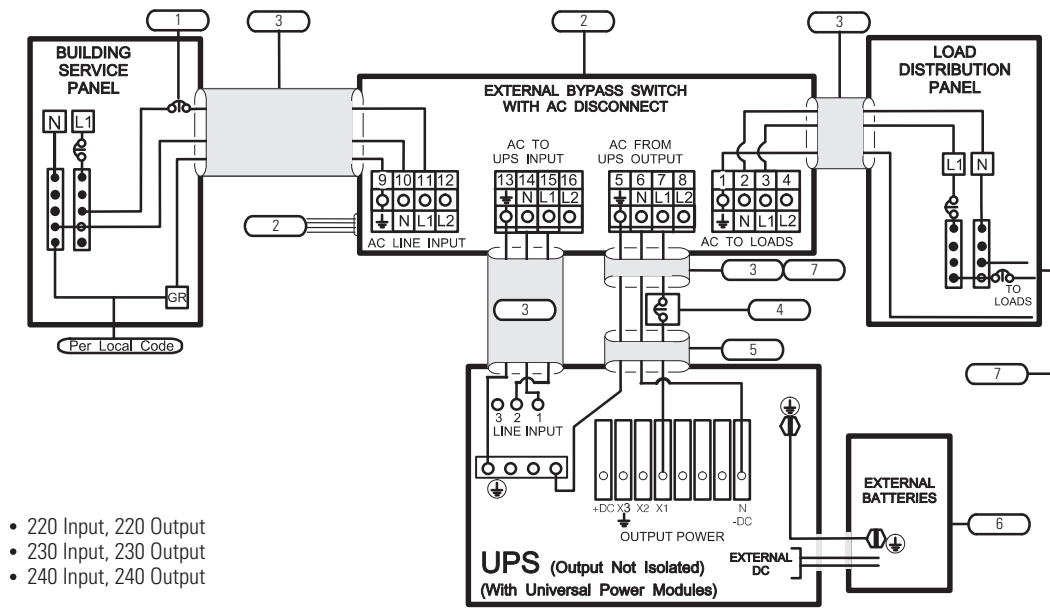

Figure 23. External Bypass Switch (L1, L2), Non-Isolated Output, Universal Power Modules



Chapter 4 UPS Electrical Installation



NOTE If you have a plug-receptacle unit, continue to “Battery Cabinet Installation” on page 45 for installing optional battery cabinets or to “UPS Startup” on page 51.



WARNING

Only qualified service personnel (such as a licensed electrician) should perform the electrical installation. Risk of electrical shock.

If a bypass switch is not used, the UPS input may be hardwired through conduit to a main power source circuit breaker, and the UPS output may either be hardwired to a circuit breaker in a distribution panel (as shown in Figure 25) or supplied to loads through receptacles on the back of the UPS. Without a bypass switch, power to the load cannot be maintained if the UPS is taken completely offline.

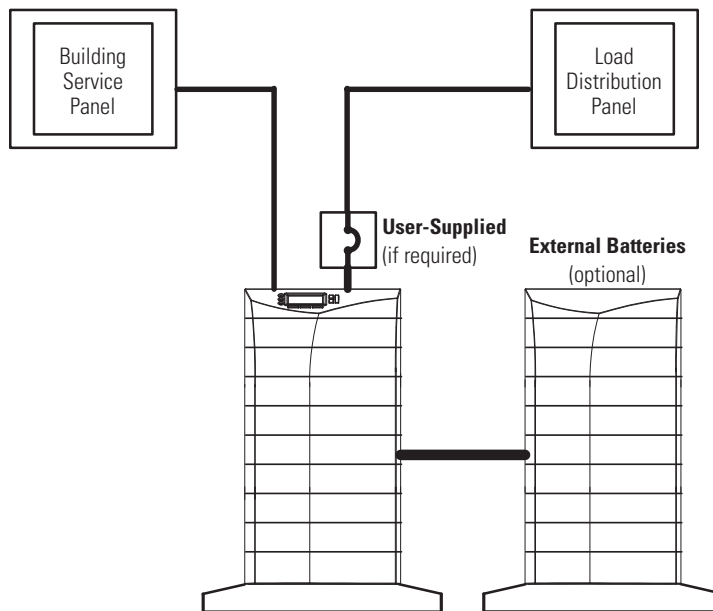

Figure 25. Typical Installation without a Bypass Switch

Input Current Ratings

Table 6 contains the required circuit breaker ratings for hardwired installations. Circuit breaker ratings for units having an input line cord are determined by the current capacity of the line cord.

Table 6. Required Input Circuit Breaker Sizes (200–240 Vac, 50/60 Hz)

UPS Capacity	Input Circuit Breaker Rating
3 kVA	25A
6 kVA	40A
9 kVA	60A
12 kVA	80A
15 kVA	100A
18 kVA	125A

NOTE 1 If you are installing an optional battery charger module, refer to that user's guide for the proper input circuit breaker sizes and ratings.



NOTE 2 To accommodate the feature of easy system expandability, it is recommended that initial installation of the Eaton 9170+ UPS contains wiring to support the maximum capacity of the UPS cabinet: 3 kVA for 3-slot cabinets; 9 kVA for 6-slot cabinets; 18 kVA for 9- and 12-slot cabinets.

See Table 7 for recommended conductor sizes to wire the input circuit breakers.

Table 7. Recommended Wire Sizes

Input Circuit Breaker Size	75°C Copper Wire Size	Conductor Screw Torque
25A	5.3 mm ² (10 AWG)	4.0 Nm (35 lb in)
40A	8.4 mm ² (8 AWG)	4.5 Nm (40 lb in)
60A	21.2 mm ² (4 AWG)	5.1 Nm (45 lb in)
80A	26.7 mm ² (3 AWG)	6.6 Nm (50 lb in)
100A	33.6 mm ² (2 AWG)	6.6 Nm (50 lb in)
125A	42.1 mm ² (1 AWG)	6.6 Nm (50 lb in)



IMPORTANT

FOR U.S. INSTALLATIONS, READ THIS IMPORTANT NOTE

- Table 7 lists the mm² and AWG wire size for each circuit breaker size shown on the wiring diagrams. The minimum recommended circuit breaker sizes for each model and voltage application are listed on the wiring diagrams.
- Conductor sizes shall be no smaller than the 75°C wire size based on the ampacities given in Table 310–16 of the National Electrical Code (NEC), ANSI/NFPA 70-1999, and article 220. All circuit conductors, including the neutral conductor, must be the same size (ampacity) wire. Code may require a larger AWG size than shown in this table because of temperature, number of conductors in the conduit, or long service runs. Follow local code requirements.

UPS Electrical Installation



WARNING

Only qualified service personnel (such as a licensed electrician) should perform the electrical installation. Risk of electrical shock.



CAUTION

To prevent electrical shock or damage to the equipment, verify that the Eaton 9170+ UPS is OFF before you remove the entrance panel. The circuit breaker or disconnect switch must also be OFF at the AC input service panel.

To install the UPS without an external bypass switch:

1. Unscrew and remove the rear cover(s) of the UPS (top cover on 3- or 6-slot; top two covers on 9- or 12-slot). See Figure 26.

The entrance panel contains knockout openings for entrance and exit conduits and for conduit to an optional external battery cabinet. The entrance panel is located on the top 3-slot section for 3- and 6-slot cabinets; on the second section for 9- and 12-slot cabinets as shown in Figure 26.

Wiring for optional emergency power-off (EPO) passes through the opening at the top back of the cabinet. Wiring for an optional generator input signal must pass through a separate opening. Installing this wiring is described in Steps 8 and 9 on page 34.

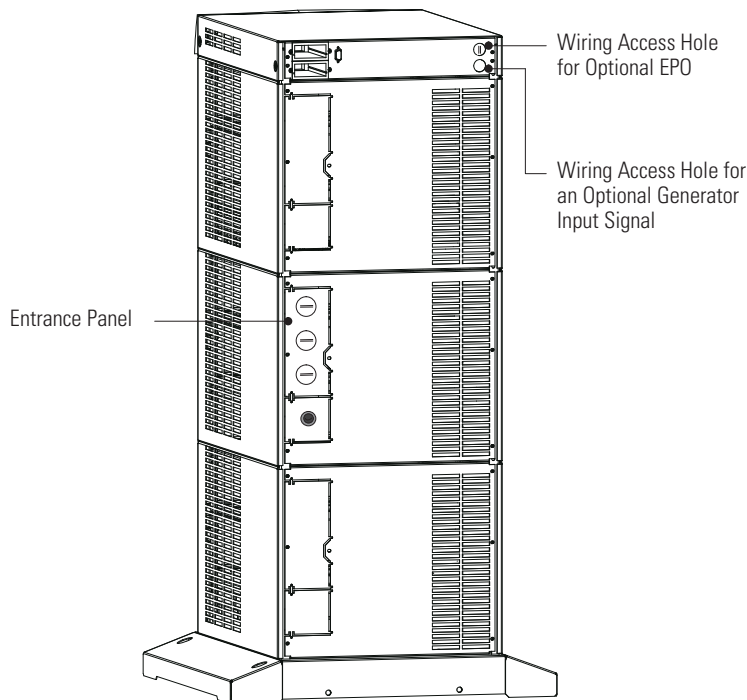

Figure 26. UPS Power Entrance Panel (Nine-Slot Cabinet Shown)

2. Remove the knockouts in the entrance panel for AC input and AC output wiring.
3. Install the conduit adapters. AC input and AC output conductors must be run through separate conduits. UPS output circuits must be installed in dedicated conduit systems and not shared with other electrical circuits.

Figure 27 shows input and output wiring terminals inside the Eaton 9170+ UPS cabinet.

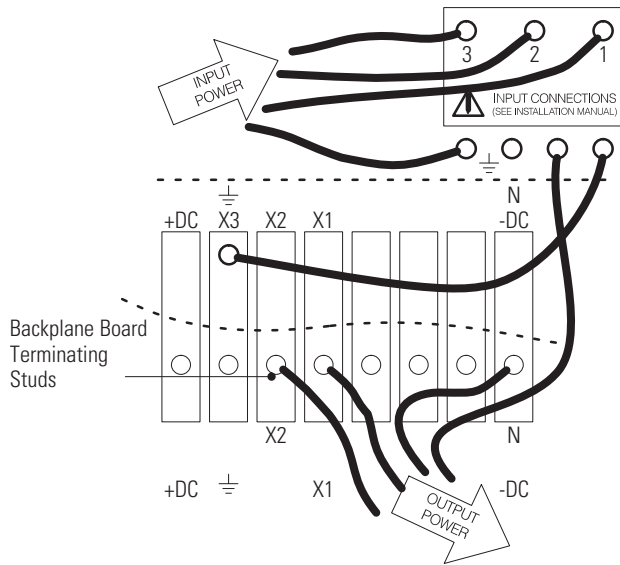

Figure 27. UPS Input and Output Terminals

4. Torque the screws holding all input and output power conductors to the values specified in Table 7 on page 30.
5. Wire the UPS for the proper input voltage as shown in Figure 28.

Split-phase power modules (model ASY-0673, with brown labels on the front) are capable of supplying two output voltages: 100/100 for 200, 110/110 for 220, 120/120 for 240, 120/120 for 208, or 127/127 for 220 Vac, as selected through the front panel display. These modules produce two output voltages, typically required in North America, South America, and Japan.

Universal power modules (model ASY-0674, with black labels on the front) are capable of supplying a single-phase output voltage: 200, 208, 220, 230, or 240 Vac, as selected through the front panel display. These modules produce a single output voltage, typically required in Europe, the Middle East, Asia, and Africa.

⚠ CAUTION

Confirm that the UPS is wired for the proper input voltage as shown in Figure 28, and that the proper power modules (either split-phase or universal) are installed to produce the desired output voltage. Do not mix the two types of power modules in the same UPS cabinet.

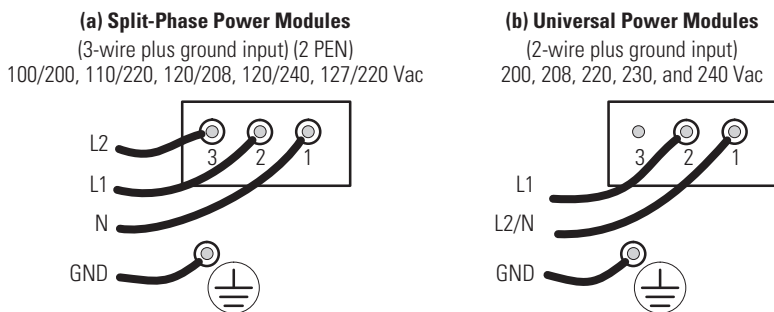

Figure 28. UPS Input Wiring

6. **For isolated output only.** See "Isolated Output Wiring Diagrams" on page 39 to complete the wiring for isolated output.
7. See the wiring diagrams beginning on page 35 for output configurations. Make UPS output connections on the backplane board terminating studs. Compression lugs (supplied in the accessory kit) may be installed on the proper terminating studs. Wires may also be terminated with ring terminals, which are attached to the output terminating studs.

Figure 29 and Figure 30 describe output wiring configurations for various output voltages. You must also set the operating menu 4 2 4 for the required output voltage as shown in the wiring configuration drawings.



NOTE For Eaton 9170+ UPS models with low-voltage hardwire output, it is recommended to divide the total load as equally as possible between X1 and X2, as shown in "Split-Phase Power Modules with Non-Isolated Output" on page 33.



NOTE Failure to balance the loads may cause an overload alarm even if the full capacity of the UPS has not been reached.

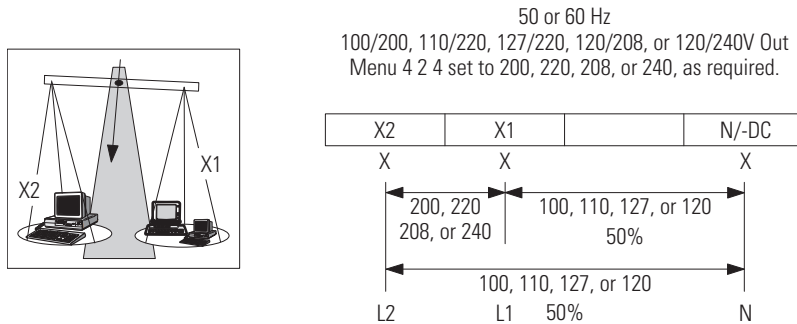

Figure 29. Split-Phase Power Modules with Non-Isolated Output



NOTE The factory-default wiring for all high-voltage receptacles in a chassis without a power cord is 3-wire plus ground input. If you have a universal power module (ASY-0674), all receptacles **MUST** be re-wired for a 2-wire plus ground input configuration as shown in Figure 30.

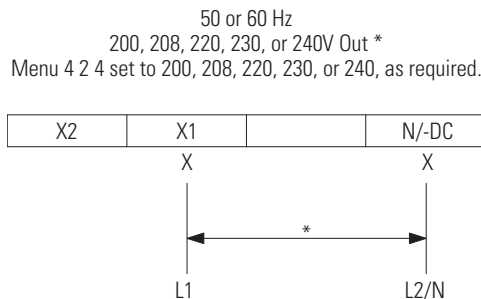

Figure 30. Universal Power Modules with Non-Isolated Output

8. If any external hardwired control signals are required (EPO or Generator On), unscrew and remove the top rear cover of the cabinet and locate the terminal block (see Figure 31).

⚠ CAUTION

EPO circuits are not isolated from line voltage, and wiring must be installed according to local codes using conduit or suitable primary supply cables.

The Generator On signal is isolated from line voltage and can be treated as NEC Class 2 wiring. Use 14–20 AWG, 600V wire (UL) or 14–26 AWG, 300V wire (CSA) for all input control signals.

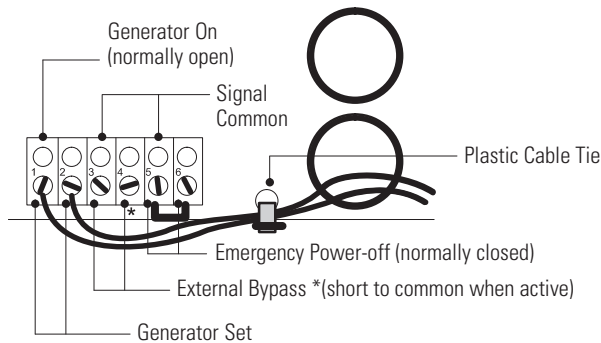

Figure 31. Input Control Signal Wiring

9. Place the signal wires through the proper conduit or grommet above the terminal block and attach to appropriate terminals. Secure each connection by torquing terminal screws to a maximum 0.4 Nm (3.5 lb in). Provide strain relief for cables by installing plastic cable ties.

NOTE Do not strain relieve EPO wiring with the same cable tie used for Generator On wires.

10. Remove the jumper between terminals 5 and 6 only if you are wiring from an EPO switch. (See “Changing Parameter Settings” on page 63 for information about accessing menu 4 3 2 to view or change the EPO switch type.)
11. When all connections have been made and checked, reinstall the UPS cabinet rear covers using the original screws.

System Wiring Diagrams

Select wiring diagrams from Table 8 based upon the installation voltage.

Table 8. Wiring Diagrams for Non-Isolated Output

UPS Input Voltage	UPS Output Voltage	Output Wires	Wiring Diagrams		
			Input	Output	System
100/200	100/200	L1, L2, N*	Figure 28a on page 32	Figure 29 on page 33	Figure 32 on page 36
110/220	110/220				
120/208	120/208				
120/240	120/240				
127/220	127/220				
200	200	L1 – L2	Figure 28b on page 32	Figure 30 on page 33	Figure 33 on page 36
208	208				
220	220				
230	230				
240	240				
220	220	L1 – N	Figure 28b on page 32	Figure 30 on page 33	Figure 34 on page 37
230	230				
240	240				

* Split-phase power modules required.

The following notes are referenced in the non-isolated system wiring diagrams (Figure 32 through Figure 34).

NOTE 1 **The customer must provide input overcurrent protection.** See NEC Section 240-21 or local requirements. See Table 6 on page 29 for circuit breaker ratings to size the protection device according to local code requirements.

NOTE 2 **The customer must size the AC circuit conductors.** All AC circuit conductors, including the neutral conductor, must be the same size (ampacity), have the same rating (75°C) copper wire, and be sized according to the input circuit breaker. See Table 7 on page 30 for recommended wire sizes. The UPS input and output conductors must be run through separate conduits.



NOTE 3 **The customer must provide output overcurrent protection.** See NEC Section 240-21 or local requirements. See Table 16 on page 76 and Table 17 on page 77 for maximum output overcurrent protection device ratings.

NOTE 4 See “Equipment Clearances” on page 7 for installation and service clearances before installing the UPS. Use flexible conduit on the UPS or the external battery cabinet if either must be moved.

NOTE 5 External UPS battery cabinets are optional. See “Battery Cabinet Installation” on page 45 for installation instructions.

NOTE 6 UPS output circuits shall be installed in dedicated conduit systems and not shared with other electrical circuits.

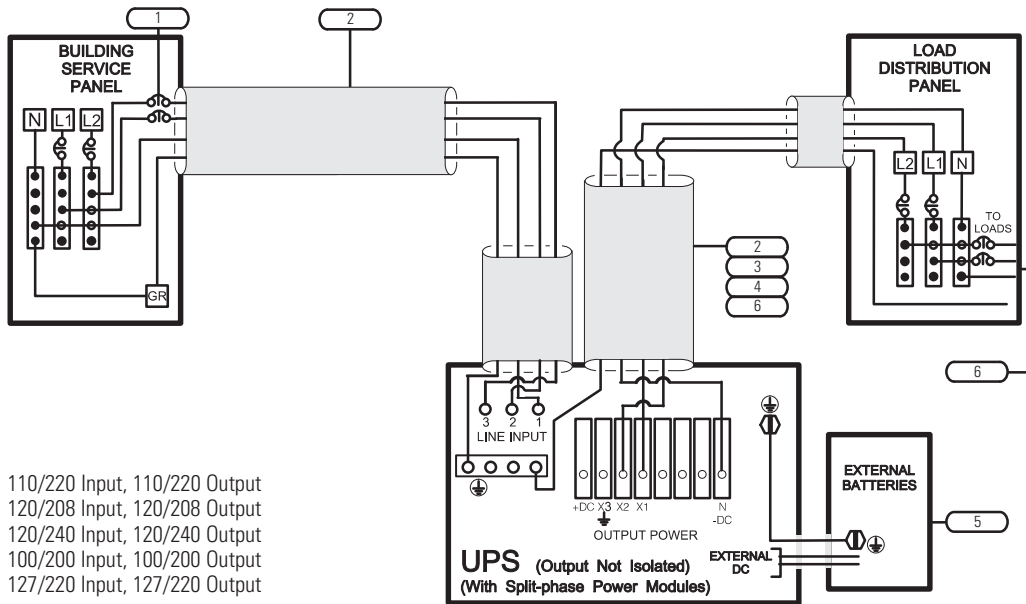

- 110/220 Input, 110/220 Output
- 120/208 Input, 120/208 Output
- 120/240 Input, 120/240 Output
- 100/200 Input, 100/200 Output
- 127/220 Input, 127/220 Output

Figure 32. No External Bypass (L1, L2, N), Non-Isolated Output, and Split-Phase Power Modules

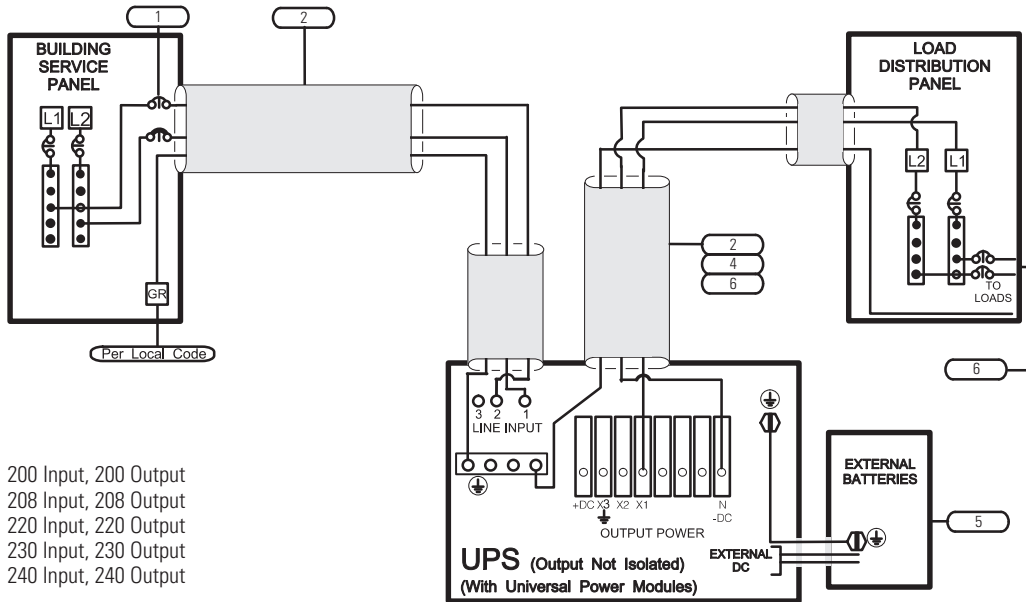

- 200 Input, 200 Output
- 208 Input, 208 Output
- 220 Input, 220 Output
- 230 Input, 230 Output
- 240 Input, 240 Output

Figure 33. No External Bypass (L1, L2), Non-Isolated Output, and Universal Power Modules

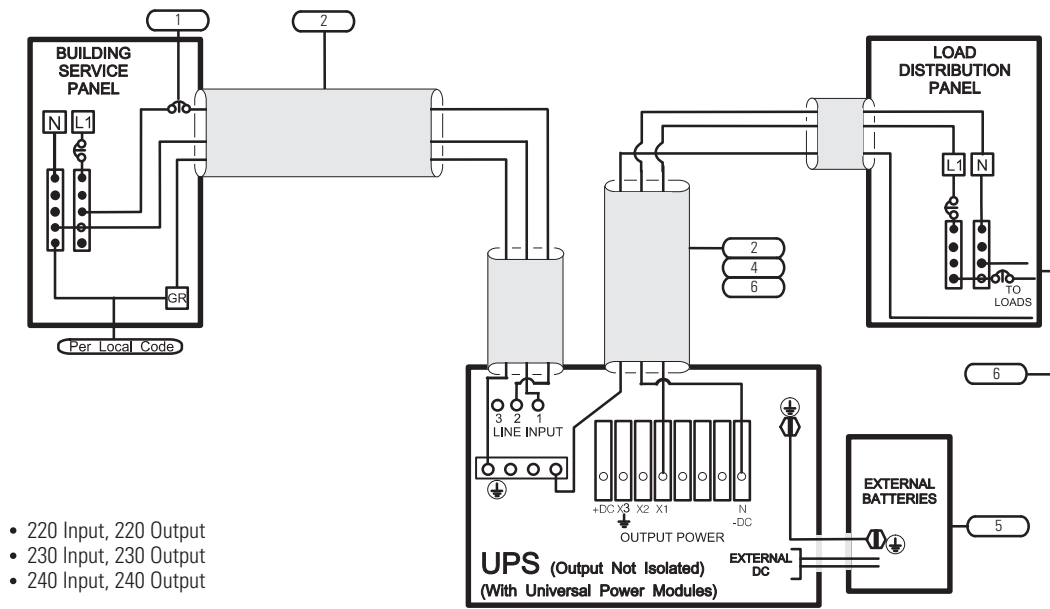

Figure 34. No External Bypass (L1, N), Non-Isolated Output, and Universal Power Modules

Chapter 5 Isolated Output Wiring Diagrams

The wiring diagrams in this section are unique and specific to installations in which the output of the Eaton 9170+ UPS is galvanically isolated from the input.

Figure 35 and Figure 36 describe output wiring configurations for various output voltages. Use Table 9 to identify the wiring diagrams and connect the output AC wiring to the proper Eaton 9170+ system power terminals. You must also set the operating menu 4 2 4 for the required output voltage as shown in the wiring configuration drawings.

NOTE 1 Do NOT install more than seven power and/or optional battery charger modules in the system.



NOTE 2 In isolated-output installations, connect the UPS green and yellow neutral-to-ground wire (N-G bond) to the UPS output terminal as illustrated in Figure 37 on page 40.

Table 9. Wiring Diagrams for Isolated Output (Split-Phase Power Modules Required)

UPS Input Voltage	UPS Output Voltage	Output Wires	External Bypass	Wiring Diagrams		
				Input	Output	System
100/200	100/200	L1, L2, N	Yes	Figure 17a on page 22	Figure 35 on page 39	Figure 38 on page 42
110/220	110/220					
115/230	115/230		No	Figure 17a on page 22	Figure 35 on page 39	Figure 39 on page 42
120/240	120/240					
120/208*	120/240					
120/208*	120/208	L1, L2, N	Yes	Figure 17a on page 22	Figure 36 on page 40	Figure 40 on page 43
127/220*	127/220					

* External bypass switch, if installed, must be Break-Before-Make.

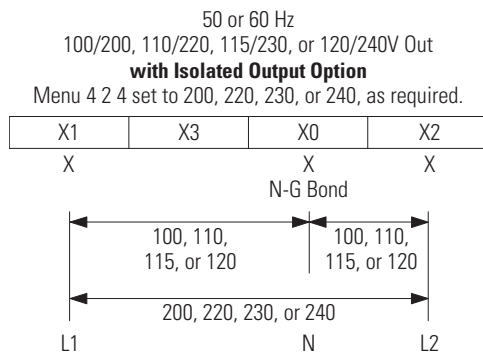

Figure 35. Isolated Outputs – Single-Phase Voltages

Isolated Output Wiring Diagrams

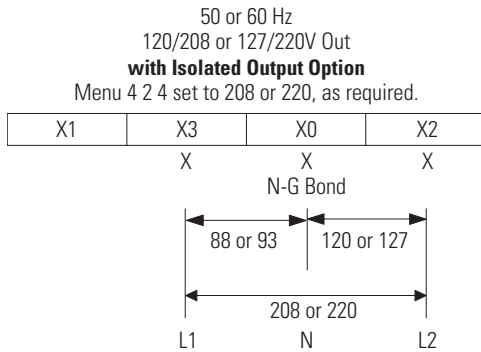

Figure 36. Isolated Outputs – Derived Three-Phase Voltages

Neutral-to-Ground Bonding for Isolated Output

As required under safety regulations issued by various regulatory agencies, the UPS cabinet must have a ground-bond connection for the neutral terminal of an isolated-output system. In such a system, the customer must make the neutral-to-ground (also referred to as N-G or neutral-to-earth) connection after selecting the desired output configuration.

In isolated-output systems, **connect the neutral-to-ground (neutral-to-earth) wire to the proper terminal before making any other connections to the UPS.** A green and yellow neutral-to-ground bonding wire is supplied, with one end connected to the ground (earth) UPS terminal as shown in Figure 37. The other end of the wire (as shown by * in Figure 37) must be attached to the proper output neutral terminal, as specified in Figure 35 and Figure 36.

Ground terminations, inside the UPS rear cover, are located directly below the line input terminals. Figure 15 on page 21 shows input and output wiring terminals inside the Eaton 9170+ UPS cabinet.

If there is any question as to the need for this bond wire, contact your local regulatory agency or your service representative.

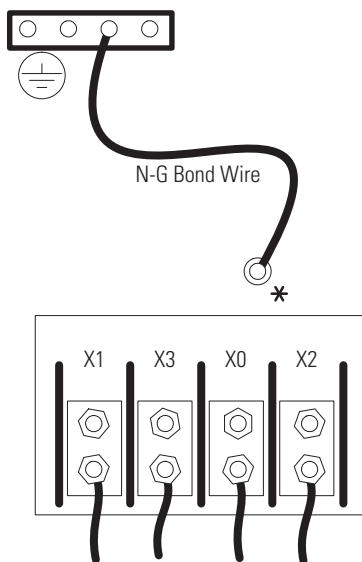

Figure 37. N-G Bond Wire

System Wiring Diagrams

The following notes are referenced in the isolated system wiring diagrams (Figure 38 through Figure 41). To determine which diagram is correct for your site, see Table 9 on page 39.

-
- NOTE 1** **The customer must provide input overcurrent protection.** See NEC Section 240-21 or local requirements. See Table 1 on page 16 for circuit breaker ratings to size the protection device according to local code requirements.
- NOTE 2** The UPS bypass switch must be installed within sight of the UPS. To properly install, complete the voltage and phase check procedure in “Startup for Hardwired Units” on page 54. The wires coming from the side of the switch must be connected as described in Step 13 on page 23.
- NOTE 3** The customer must provide and install this ground (earth) connection per NEC Sections 250-20, 250-30, 250-62, and 250-64, or local code requirements.
- NOTE 4** **The customer must size the AC circuit conductors.** All AC circuit conductors, including the neutral conductor, must be the same size (ampacity), have the same rating (75°C) copper wire, and be sized according to the input circuit breaker. See Table 2 on page 16 for recommended wire sizes. The UPS input and output conductors must be run through separate conduits.
- NOTE 5** **The customer must provide output overcurrent protection.** See NEC Section 240-21 or local requirements. See Table 16 on page 76 and Table 17 on page 77 for maximum output overcurrent protection device ratings.
- NOTE 6** For maximum protection against electrical noise, use isolated ground receptacles. See NEC Section 250-146(d).
- NOTE 7** See “Equipment Clearances” on page 7 for installation and service clearances before installing the UPS. Use flexible conduit on the UPS or the external battery cabinet if either must be moved.
- NOTE 8** External battery cabinets are optional. See “Battery Cabinet Installation” on page 45 for installation instructions.
- NOTE 9** UPS output circuits shall be installed in dedicated conduit systems and not shared with other electrical circuits.
- NOTE 10** Do not connect output wiring to X1 when connecting L1 to X3. X1 produces only 88V at 208V nominal output, and 93V at 220V.
-

Isolated Output Wiring Diagrams

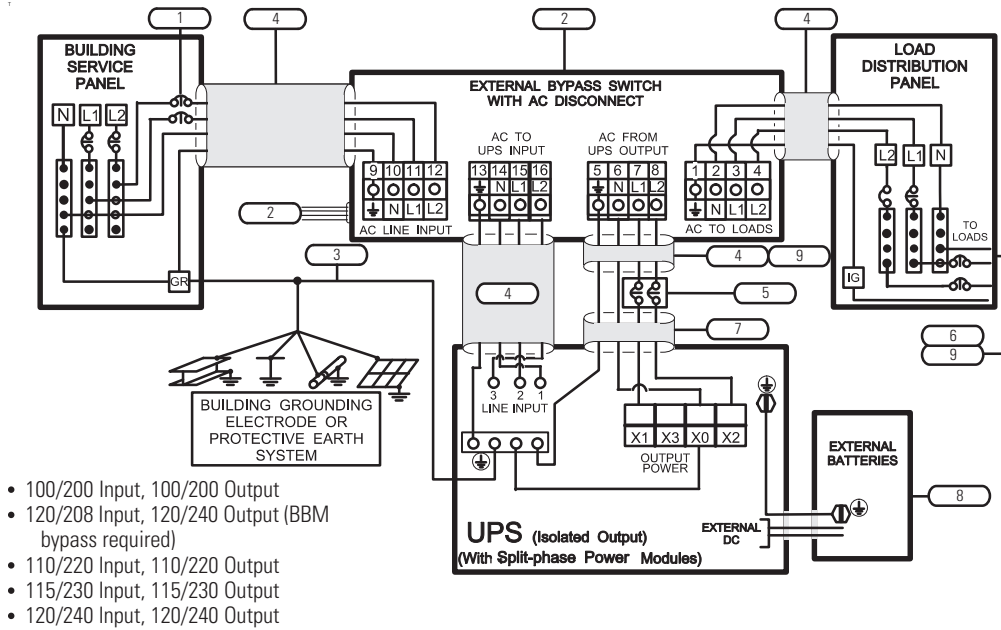

Figure 38. External Bypass Switch (L1, L2, N), Isolated Output for Single-Phase Voltages

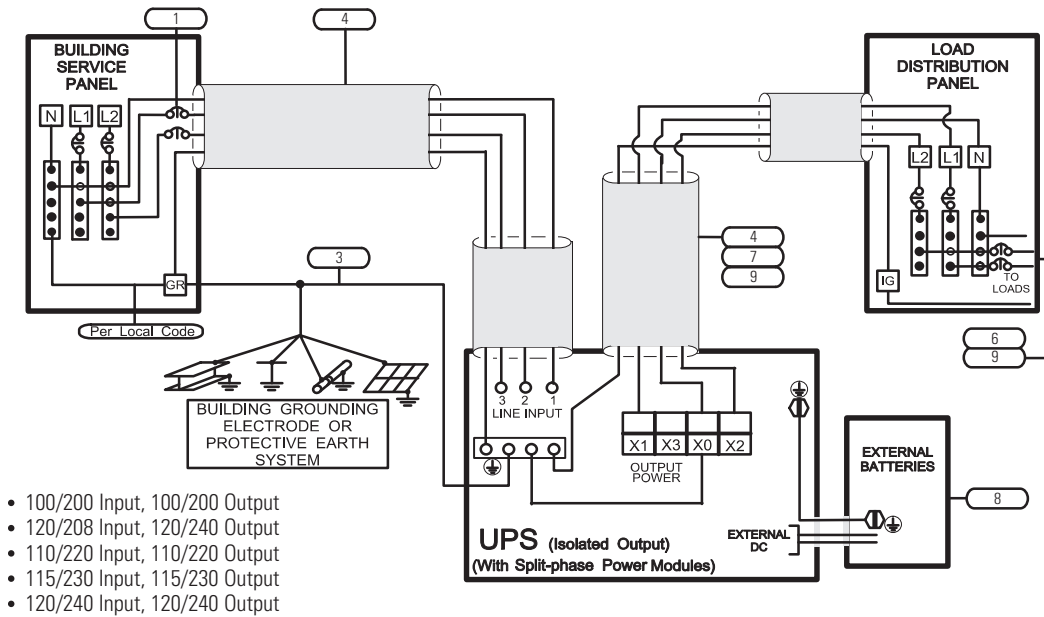
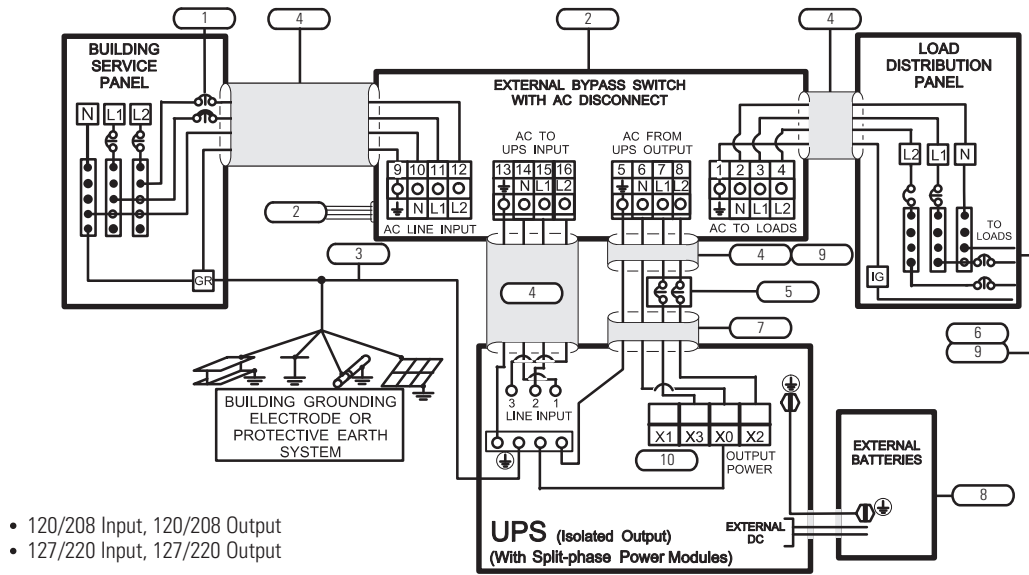

Figure 39. No External Bypass (L1, L2, N), Isolated Output for Single-Phase Voltages



(Voltages require the bypass switch to be BBM; contact your service representative for details.)

Figure 40. External Bypass Switch (L1, L2, N), Isolated Output for Derived Three-Phase Voltages

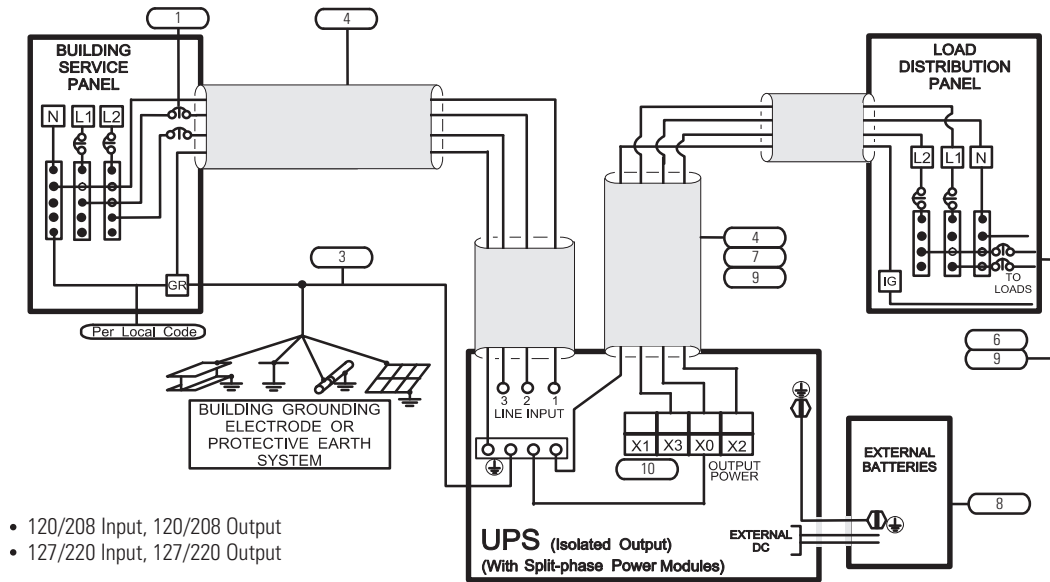

Figure 41. No External Bypass (L1, L2, N), Isolated Output for Derived Three-Phase Voltages

Isolated Output Wiring Diagrams

Chapter 6 Battery Cabinet Installation

If you are not installing battery modules into a separate external battery cabinet, continue to “UPS Startup” on page 51.

 **WARNING**

Only qualified service personnel (such as a licensed electrician) should perform the battery cabinet installation. Risk of electrical shock.

 **CAUTION**

- Before connecting an external battery cabinet to the UPS cabinet or to another external battery cabinet, verify that all AC input power is removed from the UPS. Open the input service circuit breaker or turn the external bypass switch to the SERVICE position.
 - Disconnect all battery strings in the UPS cabinet and/or battery cabinet to ensure DC voltage is removed from the internal DC buses. You can remove all battery modules or unplug each pair of battery modules from the cabinet backplane.
 - In the UPS cabinet, the proper location of cabinet-to-cabinet DC wiring is in the second cabinet section (from top).
 - In the external battery cabinets other than the ASY-0739, this wiring installs into the rear panel where the DC emergency disconnect switch is located.
 - For the ASY-0739 external battery cabinet, this connection is in the second cabinet module from the top.
 - Note that the entrance panel for the top module of ASY-0739 is solely for AC input for charger modules. The only connections from the top module to the lower modules are the copper bus bars at the left-most and right-most backplane terminals (DC+ and DC- respectively).
-

NOTE 1 The ASY-0739 is the only external battery cabinet that can accommodate a battery charger module.

NOTE 2 Only the top three slots of the ASY-0739 can accommodate battery charger modules, starting at the top slot and then downward. If the slots are not all used for battery charger modules, the remaining slots may be used for battery modules.



NOTE 3 The ASY-0739 12-slot external battery cabinet must be wired for input power from the utility AC power supply.

NOTE 4 Refer to the *Eaton 9170+ Battery Charger Module (Models ASY-0652 and ASY-0675) User's Guide* for more information.

Battery Cabinet Installation

To prepare the UPS cabinet before installing an external battery cabinet:

1. Open the carton containing the external battery cabinet cable assembly.
2. Locate the 3-slot section in the UPS cabinet that contains the power entrance panel. Unscrew and remove the rear panel of this section (see Figure 42).

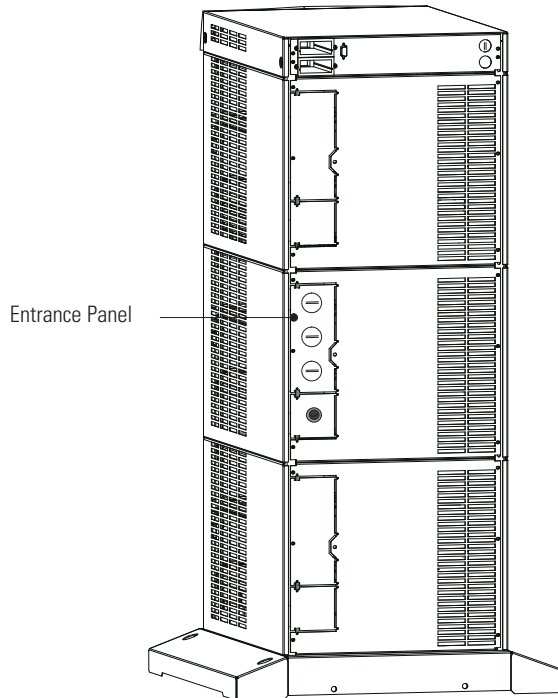

Figure 42. UPS Power Entrance Panel

3. Use a pair of pliers to bend the narrow links (1 and 2 in Figure 43) between the outer edge of the lower breakaway panel and the rear panel.
4. Use the pliers to bend the entire breakaway panel (at 3 and 4 in Figure 43) until it breaks away.

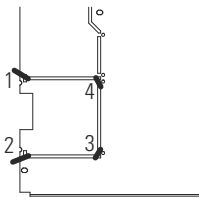

Figure 43. Breakaway Panel Links

5. Verify all hazardous voltages have been removed from the backplane by testing with a voltmeter or other test device.

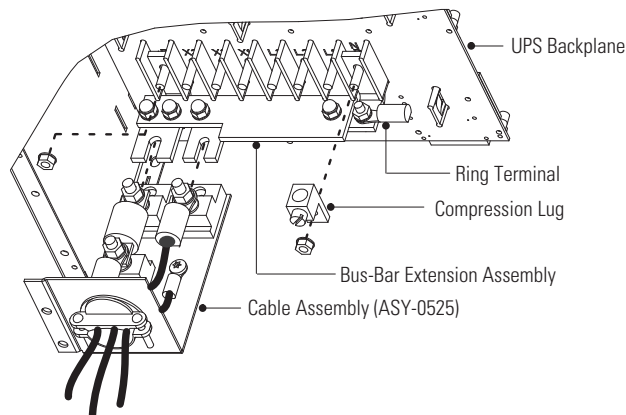

Figure 44. Bus-Bar Extension Installation

6. Remove the nuts holding the +DC and the -DC bus bars to the backplane as shown in Figure 44. Remove the ring terminal and the compression lug from the -DC bolt.
7. Position the bus-bar extension assembly onto the +DC and -DC bolts as shown in Figure 44. Replace the compression lug onto the -DC bolt of the bus-bar extension assembly. Secure the assembly by replacing the two nuts removed in Step 6.
8. Use the bolt and nut supplied with the cable assembly to attach the ring terminal to the empty hole in the -DC bus bar.
9. Torque all three bolts to 8.5–9.6 Nm (75–85 lb in).
10. Loosen the three large nuts on the end of the cable assembly (see Figure 44).
11. Slip the terminals of the cable assembly onto the tabs of the bus-bar extension, putting the tabs between the stud block and the fuse end and between the other stud block and the cable terminal.

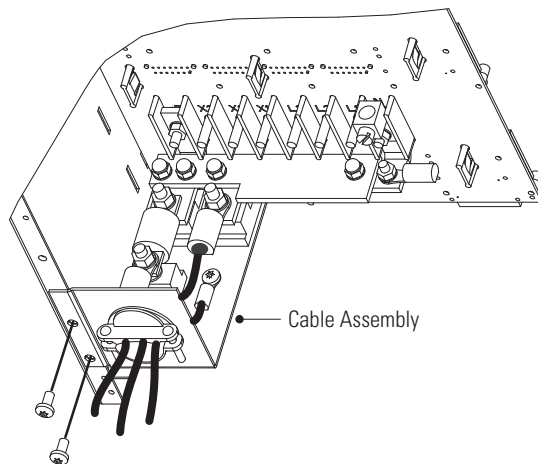

Figure 45. Battery Cable Assembly Installation

12. Align the screw holes of the cable assembly's entry plate with holes on the cabinet side cover as shown in Figure 45. Secure the entry plate with screws supplied with the cable assembly.
13. If the battery cable will be installed in customer-supplied flexible or other conduit (as required by local wiring codes), loosen the two screws holding the strain-relief clamp shown in Figure 45. Remove the clamp by loosening the star nut on the inside of the entry plate, leaving the nut in place. Replace the clamp with a panel-to-conduit feed through and secure it with the star nut.

Battery Cabinet Installation

14. Secure the cable assembly terminals by tightening the nuts onto the backplane bus bars. Also tighten the third nut, holding the other fuse end. Torque all three nuts to 8.5–9.6 Nm (75–85 lb in).
15. Reinstall the UPS cabinet rear cover using the original screws. The UPS cabinet preparation is now complete.

To install an external battery cabinet:

1. For the external battery cabinet entrance panel, attach the DC wires from the UPS (or previous battery cabinet) as shown in Figure 46. Installations with conduit will use a conduit fitting instead of the wire clamp shown.

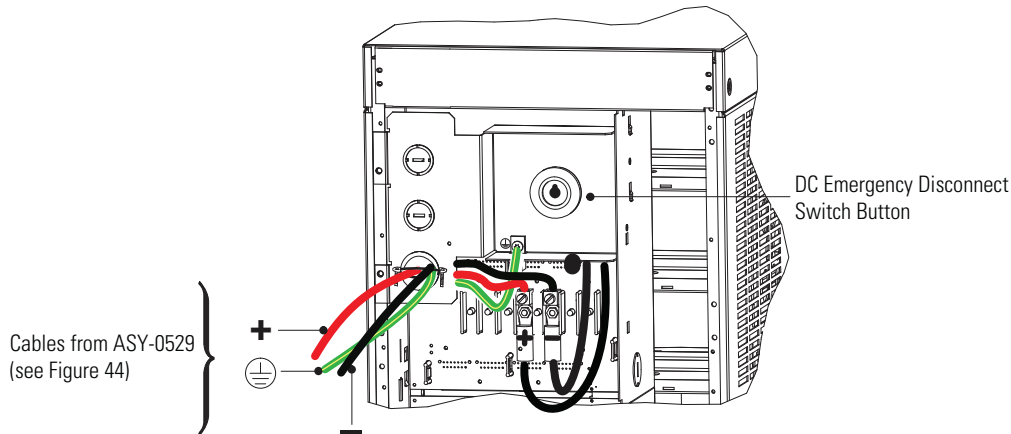

Figure 46. Battery Cable Installed in Battery Cabinet

2. Secure the **+**, the **-**, and the **⊖** conductors to the proper compression lugs on the battery cabinet backplane as shown in Figure 46. Torque all three compression lugs to 8.5–9.6 Nm (75–85 lb in).
3. If an additional battery cabinet will be connected to the first, in a daisy-chain configuration, use another external battery cabinet cable assembly for the connections between the battery cabinets (see Figure 47).
4. Locate the daisy-chained cable on the rear of the first battery cabinet in the section below the location of the first cable assembly. Follow this procedure for connecting any additional daisy-chained battery cabinets.

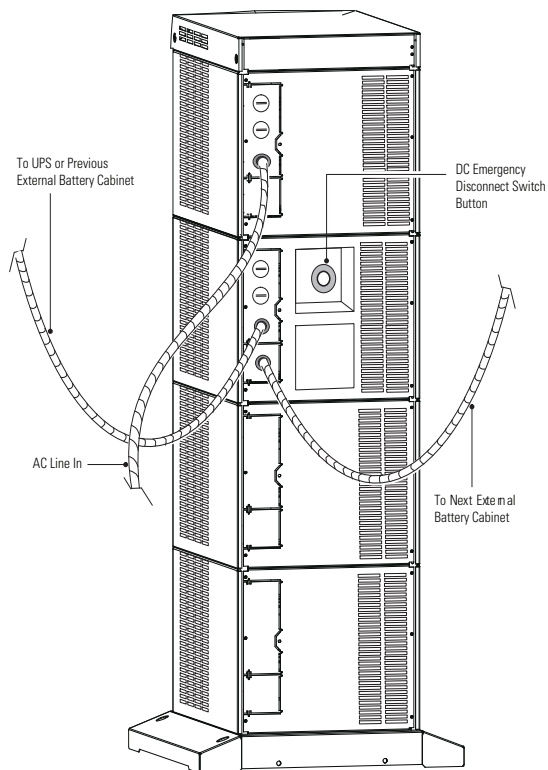

Figure 47. Connecting Additional Battery Cabinets (ASY-0739 Shown)

i NOTE Other external battery cabinets do not have the top section with AC Line in.

5. Reinstall the remaining rear covers using the original screws.
6. Continue to “UPS Startup” on page 51.

Battery Cabinet Installation

Chapter 7 UPS Startup

This section provides step-by-step instructions for starting your Eaton 9170+ system. Follow these procedures closely to avoid potential damage to your equipment or the UPS and to protect yourself and others from hazardous operating conditions.

CAUTION

- This UPS contains its own energy source (batteries). The output receptacles may carry hazardous voltage even when the UPS is not connected to an AC supply. When AC input voltage is present, the Eaton 9170+ system can provide output voltage even though its batteries are disconnected. To confirm that there is no UPS output voltage, always disconnect all of the AC input sources and unplug all strings of internal battery modules; if the UPS has one or more separate battery cabinets, open (push in) the DC emergency disconnect switch button on each battery cabinet or unplug all battery strings in each battery cabinet.
 - To reduce the risk of fire or electric shock, install this UPS in a temperature and humidity controlled, indoor environment, free of conductive contaminants. Ambient temperature must not exceed 40°C (104°F). Do not operate near water or excessive humidity (95% maximum).
 - For optimum battery life, ambient temperature should not exceed 25°C (77°F). Battery life is substantially reduced if ambient temperature is higher.
 - Do NOT lower the casters or attempt to move the cabinet with the power or battery modules installed.
-

Power and Battery Module Installation

To install the power and battery modules into the Eaton 9170+ cabinet:

1. Remove the front cover(s) of the cabinet. The covers have spring latches on the left and right sides that hold them in place.

NOTE 1 Place battery modules below all power modules in the UPS cabinet. Two battery modules (side-by-side) are required to complete each battery string.

 **NOTE 2** If you are installing a battery charger module in the UPS cabinet, place it above the battery modules. Refer to the *Eaton 9170+ Battery Charger Module (Models ASY-0652 and ASY-0675) User's Guide* for more information.

2. Insert the battery modules into the cabinet. Push each module firmly until the front latch snaps to secure the battery module (see Figure 48). Repeat for each additional battery module.

NOTE 1 All power modules in the Eaton 9170+ UPS cabinet must be of the same type: Split-phase power modules have brown labels; universal (single-phase) power modules have black labels. Do not mix brown and black modules in the same UPS cabinet.

 **NOTE 2** Do NOT install more than seven power and/or optional battery charger modules in the system.

3. Insert the power modules into the upper slots of the cabinet. To insert a power module:
 - Lower the front slightly and lift the rear edge over the safety stop on the center support rail. Keep the module handle extended until the module is fully inserted (see Figure 48).
 - Raise the power module handle to secure the module into the cabinet. Be sure the handle latch snaps into place. Tighten the thumbscrew on the handle.

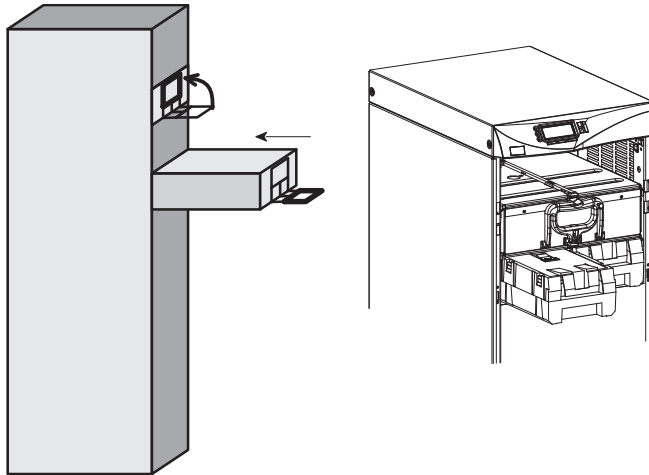

Figure 48. Inserting the Modules

4. If you installed an optional battery cabinet, repeat Steps 1 and 2 to install the battery modules.
5. Reinstall the front cover(s).
6. Continue to the following section, “Startup for Plug-Receptacle Units” if your cabinet has a power cord already attached. If you hardwired the UPS, skip to “Startup for Hardwired Units” on page 54.

Startup for Plug-Receptacle Units

To start a plug-receptacle unit:

1. Plug the power cable of the unit into an approved, functional power outlet.
2. If external battery cabinets are installed, check the cable connections between the UPS and external battery cabinets.

Close the DC emergency disconnect switch button on the back of each external battery cabinet. Insert the switch key supplied with the cabinet into the button and turn clockwise 1/2-turn. Pull the button out to close the switch. Turn the key back counter-clockwise, and remove the key.

3. Ensure that all power modules are properly installed and latched into the UPS cabinet.
4. If you are installing power management software, connect your computer to the UPS communication port (shown in Figure 49) using the supplied communication cable.

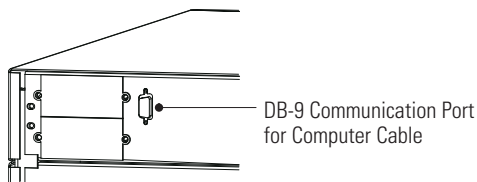

Figure 49. Communication Port

5. The UPS front panel display automatically turns on whenever input power is present and at least one power module is installed. Set up the initial operating parameters through the front panel display (see “Initial Startup Parameters” on page 56).

NOTE 1 The unit has no physical On/Off switch. Access the UPS On/Off function through the front panel display.

i **NOTE 2** If the UPS has been manually set to operate in Bypass or Battery mode, change the System Control Mode Preference (menu 4 1) selection to Auto to return to normal Auto mode operation.

6. If applicable, test proper operation of optional external control signals and computer communication before connecting the load. (See “DB-9 Communication Port” on page 69 for details.)
7. Plug the equipment to be protected into the UPS output receptacles. Turn on the equipment that is connected to the UPS.

NOTE 1 DO NOT protect laser printers with the UPS because of the exceptionally high power requirements of the heating elements.

i **NOTE 2** The factory-default wiring for all high-voltage receptacles in a chassis without a power cord is 3-wire plus ground input. If you have a universal power module (ASY-0674), all receptacles MUST be re-wired for a 2-wire plus ground input configuration as shown in Figure 19 on page 23.

NOTE 3 The total volt-ampere load must not exceed the volt-ampere rating of the entire cabinet. Failure to balance the loads may cause an overload alarm even if the full capacity of the UPS has not been reached.

For Eaton 9170+ UPS models with low-voltage output receptacles, it is recommended that you divide loads between upper and lower receptacles as equally as possible. (In some configurations, each set of receptacles is limited to one half of the total UPS capacity.)

Whether the cabinet has one panel containing eight receptacles, two panels containing 16 receptacles, or three panels containing 24 receptacles, you should try to supply half of the UPS output through the upper half of the receptacles (X1) and the other half through the lower half of the receptacles (X2), as shown in Figure 50.

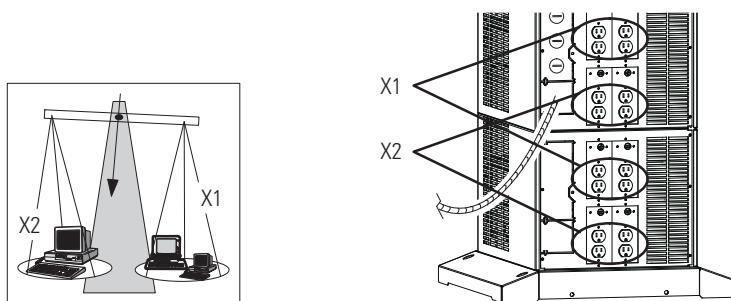

Figure 50. Balancing Receptacle Loads

Startup for Hardwired Units

To start a hardwired unit:

1. Confirm that an electrician has completed and tested the connection to the proper power source.
2. If external battery cabinets are installed, check the cable connections between the UPS and external battery cabinets.
3. Ensure that all power modules are properly installed and latched into the UPS cabinet.
4. If you are installing power management software, connect your computer to the UPS communication port (shown in Figure 51) using the supplied communication cable.

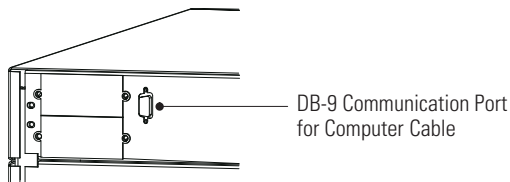

Figure 51. Communication Port

5. If your unit is wired to an external bypass switch, you must perform a voltage and phase check (Steps 6 through 17). Otherwise, skip to Step 18.

⚠ CAUTION

Before operating the bypass switch, use the following procedure to check the wiring for correct installation. To prevent damage to the load, turn off the main circuit breaker in the load service panel or verify that the load cannot receive power from the UPS.

6. At the bypass switch, press the red button and turn the switch to UPS.
7. Remove the six screws in the bypass switch front cover and remove the cover to gain access to the terminal block for voltage measurements.
8. If external battery cabinets are installed, close the DC emergency disconnect switch button on the back of each external battery cabinet. Insert the switch key supplied with the cabinet into the button and turn clockwise 1/2-turn. Pull the button out to close the switch. Turn the key back counter-clockwise, and remove the key.
9. The UPS front panel display automatically turns on whenever input power is present and at least one power module is installed. Set up the initial operating parameters through the front panel display (see "Initial Startup Parameters" on page 56).

NOTE 1 The unit has no physical On/Off switch. Access the UPS On/Off function through the front panel display.

i NOTE 2 If the UPS has been manually set to operate in Bypass or Battery mode, change the System Control Mode Preference (menu 4 1) selection to Auto to return to normal Auto mode operation.

10. Use an AC voltmeter to measure voltages on the terminal block inside the bypass switch cabinet. See Figure 16 on page 21, which shows the terminal numbering for input and output UPS connections.
11. Record your measurements in the following chart. The voltages in the first column should be nearly equal to the voltages in the second column. If the values differ by more than a few volts, check the terminal block connections and correct any wiring problems.

AC Line Input	Measurement	AC from UPS Output	Measurement
L1 to L2 (11 to 12*)		7 to 8*	
N to L1 (10 to 11*)		6 to 7*	
N to L2 (10 to 12*)		6 to 8*	

* For some installations, there is no connection at terminals 6, 8, 10, or 12.

12. Determine what type of bypass switch you are using:
 - If the bypass switch is a Break-Before-Make type, skip this step and proceed to Step 13.
 - If the bypass switch is a Make-Before-Break type, verify that the AC voltages from the UPS and the AC line input are in phase. Measure the voltage between the following points on the terminal block and record in the spaces below. These measurements must be no more than 20 Vac; if they are, call your service representative.

Terminal 7 to 11

Terminal 8 to 12

13. Measure the AC voltage between the following points on the terminal block and record in the space below. This reading must be no more than 1 Vac; if it is, call your service representative.

Terminal 6 to 10

14. Switch the bypass switch to LINE. Measure the voltage to the protected equipment (at the load distribution panel) and verify that it is correct.
15. Switch the bypass switch to UPS and verify the voltage to the protected equipment is still correct.
16. Reinstall the bypass switch front cover and UPS front covers using the original screws.
17. If the UPS will not be operated immediately, switch the bypass switch to SERVICE and push in the DC emergency disconnect switch button on the back panel of the external battery cabinet closest to the UPS. Otherwise, skip to Step 20 to continue the UPS startup.
18. When starting the UPS, apply input power to the UPS by closing the service circuit breaker:
 - If external battery cabinets are installed, close the DC emergency disconnect switch button on the back of each external battery cabinet. Insert the switch key supplied with the cabinet into the button and turn clockwise 1/2-turn. Pull the button out to close the switch. Turn the key back counter-clockwise, and remove the key.

19. The UPS front panel display automatically turns on whenever input power is present and at least one power module is installed. Set up the initial operating parameters through the front panel display (see "Initial Startup Parameters" on page 56).

NOTE 1 The unit has no physical On/Off switch. Access the UPS On/Off function through the front panel display.

 **NOTE 2** If the UPS has been manually set to operate in Bypass or Battery mode, change the System Control Mode Preference (menu 4 1) selection to Auto to return to normal Auto mode operation.

20. If applicable, test proper operation of optional external control signals and computer communication before connecting the load. (See "DB-9 Communication Port" on page 69 for details.)
21. If there are receptacles on the UPS rear panel, plug the equipment to be protected into the UPS output receptacles.

 **NOTE** DO NOT protect laser printers with the UPS because of the exceptionally high power requirements of the heating elements.

22. Turn on the equipment that is connected to the UPS.
23. If there is an external bypass switch, turn it to UPS. Otherwise, close the load distribution circuit breaker(s).

Initial Startup Parameters

The first time the UPS is turned on, you must set or verify certain operating parameters before placing the UPS into operation. To set these initial configuration parameters:

1. Enter the correct user security password: 0377. Move left and right by pressing the buttons below the <- and -> on the display. To change the value of the selected digit, press the ▲ and ▼ buttons. When the password shows 0377, press the ↵ button.

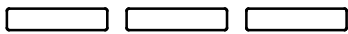
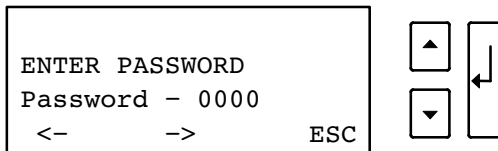

2. Select the desired language for the display. Use the ▲ and ▼ buttons to scroll between English, French, German, and Spanish. Enter your selection by pressing the ↵ button.

- Set the clock for the local time and date.
 - If the time or the date is correct as displayed, press the button to advance to the next configuration setting. Time must be entered in 24-hour format.
 - If the time is incorrect as displayed, press the and buttons to move left and right. Press the and buttons to increase or decrease the value of each selected digit. When the displayed value is correct, press the button.

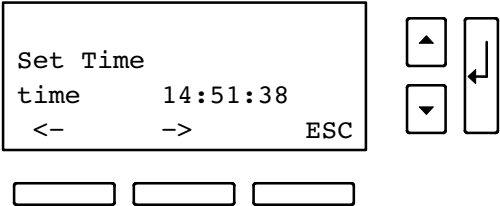

- The output voltage is the most important operating parameter you must set as part of the initial configuration screens. Select the desired UPS output voltage using the and buttons. Possible selections are 200, 208, 220, 230, and 240 Vac. Press the button when the desired output value is displayed.

NOTE Low voltages are derived from these voltages, as listed in Table 5 on page 25 and Table 9 on page 39.

- If the system includes any external battery cabinets, record the ampere-hour capacity of batteries installed in these cabinets. If using a standard cabinet, count the number of battery strings (two battery modules side-by-side equals one string). Each battery string contains 7.2 ampere-hours. Enter the total value in the next startup screen.

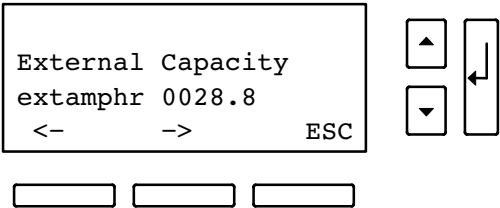

- The system signals an alarm when the required output cannot be maintained with the loss of redundant power modules. The alarm is essentially disabled with a redundancy level set at 0.
- Optional.** If you want the system to notify you when the number of redundant power modules is less than a specified level, enter a redundancy level. Each increment above 0 indicates the number of modules that can be removed from operation before the alarm occurs. This setting affects only the alarm; the system continues to operate as an N+X system even if this parameter is left at the default value of 0.

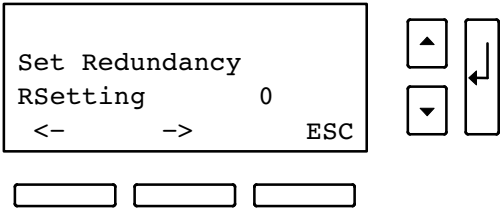

- To password-protect the UPS On/Off function, press the ▲ or ▼ button to make your selection; then press the ← button. If a password is required, the UPS On and Off functions are accessible only after first entering the correct password value (0377).

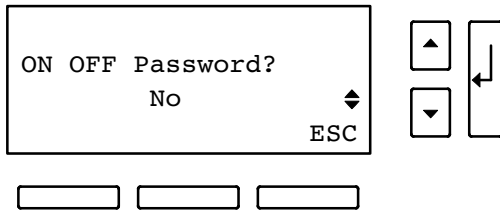

- The UPS is now ready to operate, and displays the normal On/Off function screen. Press the ON button on this screen to start the UPS.



NOTE

These configuration parameters are accessible during normal UPS operation by pressing the Config button through the front panel display.

Chapter 8 Operation

The Eaton 9170+ UPS operates in several different modes. Normally it operates under internal control (Auto mode) to automatically protect loads connected to it. An operator can enable manual override should servicing or testing be required.

Figure 52 shows the operating modes. In Auto mode, the UPS automatically switches between modes depending on line and load conditions.

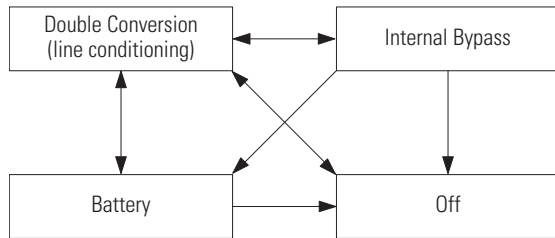

Figure 52. UPS Operating Modes Under Auto Mode Control

Double Conversion mode produces output power from the internal DC bus. The AC input power is rectified and boosted to supply this DC bus. The UPS switches automatically to and from Battery mode with no interruption (0 ms transfer time) as AC input power drops and returns. Batteries are charged in this mode.

Battery mode produces power from the batteries to supply the internal DC bus.

Internal Bypass (Bypass) mode shunts power flow around the DC/AC internal circuitry to keep the output powered with no line conditioning. Electromagnetic interference (EMI) and surge circuitry still protect the loads from voltage spikes and noise.

High Efficiency (H.E.) mode is a user-programmable automatic mode that allows power to flow through the internal UPS bypass path for as long as AC input stays within the user-defined set points. If the input voltage or frequency deviates beyond these set points, the UPS transfers to Double Conversion mode. Complete loss of input voltage causes the UPS to transfer to Battery mode. While in H.E. mode, the UPS provides passive EMI filtering in the power path.

Off mode turns off the output and most internal circuitry. Within this mode, Sleep mode turns off all internal circuitry when AC line is not present and battery voltage drops to a low threshold. If AC input voltage is not present in Off mode, the user can direct the UPS to enter Sleep mode by selecting the Battery Protect (BP) feature (see “Removing Input Power” on page 60). When AC input voltage returns in the Off mode (caused by a low battery alarm condition), the UPS automatically recovers and, if the Auto Restart parameter is enabled, switches to Double Conversion mode. Auto Restart is enabled as a factory-default.

After a discharge and subsequent low-battery shutdown, the UPS automatically recovers from Sleep mode if the Auto Restart parameter is enabled.

Figure 53 shows the basic functional elements of the UPS.

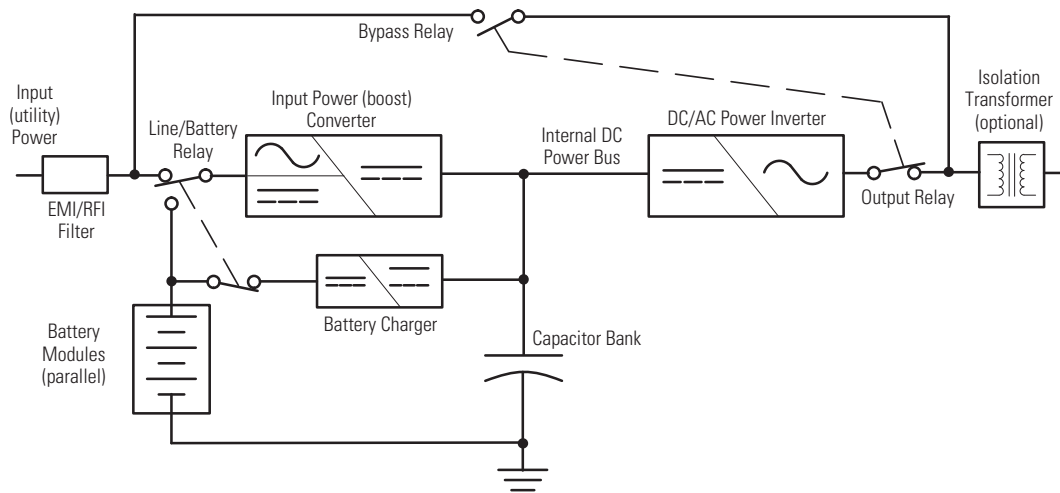

Figure 53. UPS Functional Block Diagram

Turning the UPS On

The unit has no physical On/Off switch. Access the UPS On/Off function through the front panel display.

If the UPS is off, press the ON button through the front panel display to turn the UPS on again.

If the UPS has been manually set to operate in Bypass or Battery mode, change the System Control Mode Preference (menu 4 1) selection to Auto to return to normal Auto mode operation.



NOTE

The UPS will not start operating if AC input voltage or frequency is beyond acceptable limits or if the system mode selection is set to Battery. The UPS cannot go directly from Off to Battery.

Removing Input Power

Always transfer the UPS to Off mode before removing input power. The batteries will discharge if the input line voltage is disconnected or turned off without first turning off the UPS.

If the input power source will be disconnected or turned off for more than a day or two, transfer the UPS to Sleep mode: turn the UPS off, remove AC input power, press the On button, and then select Battery Protect (BP). Sleep mode allows the UPS to remain unpowered for up to six months without having to remove or recharge batteries.

Failure to properly power down the UPS could permanently damage any installed batteries. Also, if batteries become severely discharged, the UPS might not start immediately when input power is restored.

Front Panel Display

The front panel has an alphanumeric display, three LED indicators, and six pushbuttons as described in Figure 54 and in Table 10.

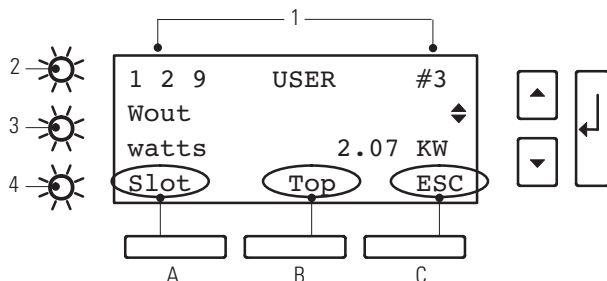

Figure 54. UPS Front Panel

Table 10. Front Panel Details

Item	Description
1	Alphanumeric display of unit function and operating parameters. Also displays alarm/data logs.
2	Alarm LED (red) Illuminates to signal that the unit has detected an alarm condition.
3	Battery LED (yellow) Illuminates to signal that the unit is operating on battery power and producing output voltage.
4	Line LED (green) Illuminates to signal that the unit is operating on AC utility power and producing output voltage.
A and B	Multi-function buttons, as labeled by the bottom line of the alphanumeric display.
C	Menu/Escape button, for moving into and out of display menus. Also, for avoiding a change to a parameter value.
▲ and ▼	Menu scroll up and down buttons. Also, for increasing/decreasing parameter value digits.
↵	Enter button, to activate/accept displayed parameter or operating mode.

Using the Front Panel Display

Figure 55 shows an example of the front panel display. The numbers in the upper left corner (1 2 9 in Figure 55) indicate the menu level. The word in the top center (USER) is the security level.

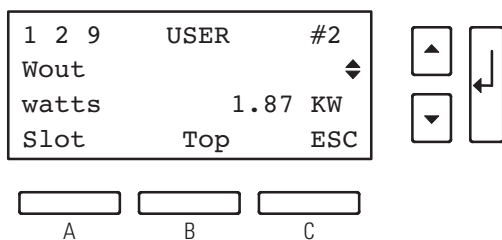

Figure 55. Typical Front Panel Display

The number in the upper right corner (#2) identifies the cabinet slot (numbered from the top down) for a specific power module. #0 is defined as System, for observing overall system operation.

One or two triangles at the right of the display indicate which arrow buttons are active for moving within a menu level. See Figure 60 on page 66 for the complete system menu.

Operation

The words or symbols in the bottom line of the display define the function of the three buttons below the display:

- In Figure 55, Slot (button A) lets you observe the operation of a specific power module (the module in slot #2, in this example) or the overall system (slot #0).
- Top (button B) moves to the top item in the current menu level (in this example, 1 2 1).
- ESC (button C) exits the current menu level (in this example, to menu 1 2).

During normal operation, the display is shown in Figure 56:

Md: Current UPS operating mode
St: Operational state
Mn: Number of power modules
Bn: Number of battery module strings currently online
nn: Total number of module slots in the cabinet

The count of battery strings does not include additional battery strings contained in connected external battery cabinets.

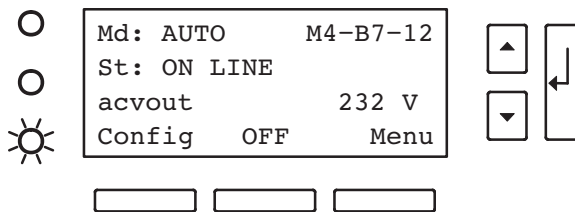

Figure 56. Front Panel Display (Normal Operation)

Operating parameters on the third line of the display vary depending on the operating mode. Use the ▲ and ▼ buttons to scroll through the available parameters. After five seconds of inactivity, the system automatically saves the parameter that was selected as the default display parameter. The parameters available for display are:

- Phase 1 Input Voltage
- Phase 2 Input Voltage
- Phase 1 Output Voltage
- Phase 2 Output Voltage
- Total System Percent Load
- Phase 1 Percent Load
- Phase 2 Percent Load
- Battery Voltage
- Estimated Battery Runtime

Parameters

The parameters describe the UPS operation. Some useful parameters are input and output voltage, input and output current, and battery voltage, among others. Some are operator adjustable, such as the local date and time and various operating limits. All parameters are password-protected. Although every operating condition and parameter is accessible through the front panel display, you may change a value only if you have entered the correct password.



NOTE

After 10 minutes of inactivity, the UPS automatically deletes any active password level and returns to the normal running display.

Changing Parameter Settings

Changing an operating parameter is similar to setting initial parameters, as described in “Initial Startup Parameters” on page 56:

1. Use the Menu map (Figure 60 on page 66) to find the parameter you need to change, and move through the menu structure until the parameter name appears on the display.
2. Press the \leftarrow button to access the parameter value. The Enter Password screen automatically opens if permission is required for a particular parameter.
3. Enter the appropriate password, if applicable, and then change the parameter value.
4. Press the \leftarrow button again to save the change. To not save the change, press ESC instead of the \leftarrow button.

Reading the Eaton 9170+ System Logs

The Eaton 9170+ system makes an entry in its logs each time it sounds an alarm or runs on battery power. This information can help in diagnosing power problems. You can display the UPS Inverter and Alarm logs on the front panel display in menu 2.

Inverter Log

The inverter (Battery mode) log is in menu 2.1. Move through the menu structure by pressing the Menu button and pressing the \blacktriangledown button to move down to menu 2. Press \leftarrow to move to submenu 1 and press \leftarrow again to view the most recent entry in the inverter log.

The log stores up to 10 entries, in chronological order. Use the \blacktriangle and \blacktriangledown buttons to scroll up and down through the log entries. Each entry shows the date and time the unit switched to battery operation (in 24-hour format) and the duration of battery operation (in hours and minutes). A typical Inverter Log entry is shown in Figure 57:

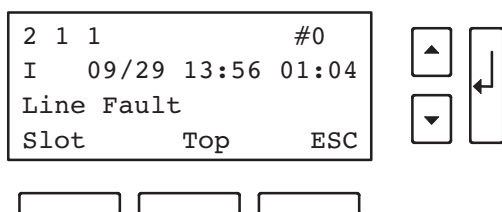

Figure 57. Inverter Log Entry

Figure 57 displays the most recent inverter log (2 1 1). If the unit is still running on inverter (battery power), an asterisk (*) appears beside the date. The Battery mode operation occurred on 09/29 (September 29) at 13:56 (1:56 p.m.), and the batteries supplied power for 01:04 (1 hour and 4 minutes).

Table 11 lists the inverter messages.

Table 11. Inverter Log Messages

Message	Explanation
Line Fault	UPS switched to battery because the input voltage was too high or low.
Battery Test	Battery test initiated inverter operation.
Manual	Operator initiated inverter operation.

Alarm Log

The alarm log is in menu 2.2. Move through the menu structure by pressing the Menu button and pressing the ▼ button to move down to menu 2. Press ← and then press the ▼ button to move down to submenu 2. The display shows the most recent entry in the alarm log.

The log stores up to 10 entries, in chronological order. Use the ▲ and ▼ buttons to scroll up and down through the log entries. Each entry shows the alarm code, the alarm date and time (in 24-hour format), and the duration (in hours and minutes). A typical alarm log entry is shown in Figure 58:

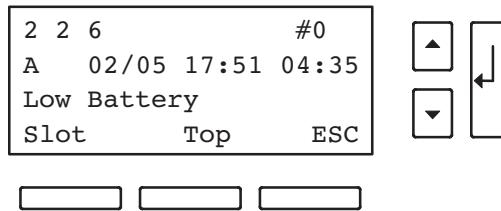

Figure 58. Alarm Log Entry

Figure 58 displays the sixth most-recent alarm (2 2 6). This UPS sounded alarm A (Low Battery). If the alarm is still active, an asterisk (*) displays beside the letter alarm code. The alarm occurred on 02/05 (February 5) at 17:51 (5:51 p.m.), and the alarm was active for 04:35 (4 hours and 35 minutes).

Some alarms indicate the specific power or battery module slot number. Slot: nn appears in the upper right hand corner, as shown in Figure 59, indicating the slot number where the fault occurred.

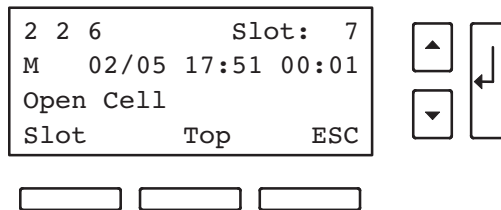

Figure 59. Alarm Entry for Specific Slot Number

Table 12 lists the alarm log messages.

Table 12. Alarm Log Messages

Message	Explanation
Open Cell	Battery failure caused by open cell.
Weak Battery	Battery failure caused by load test.
Phase Error	Internal error — contact your service representative.
Module Failure	Internal error — contact your service representative.
Excessive Transfers	Internal error — contact your service representative.
Precharge Failure	Internal error — contact your service representative.
Insufficient Batteries	Too few battery modules; decrease load or add battery modules.
Insufficient Modules	Too few power modules; decrease load or add power modules.
Incompatible Module	A power module with incompatible firmware has been installed in the system; contact your service representative.

Battery Test



NOTE The batteries must be fully charged and the UPS must not have been on battery within 24 hours of the battery test.

The Eaton 9170+ battery test runs automatically every 30 days by default and can also be performed manually. When the test is complete, the UPS automatically displays the results.

To initiate a manual test, select menu 3 1 1. Use menu 3 1 to set the battery test parameters, including the test interval and time of day.

During the battery test, the Eaton 9170+ performs an open cell test and displays the message “Open Cell Test” (firmware versions 2.22 and later) or “Open Cell” (firmware versions prior to 2.22). Both of these messages are different from the Open Cell alarm.

Menu Map

Figure 60 shows all the Eaton 9170+ system parameters. The menu structure has six primary-level menus, System Status Menu (1) through Service Menu (6). Each primary menu has secondary items numbered by their location under the primary menu. Use the various buttons as shown in the map to navigate to the desired parameter.

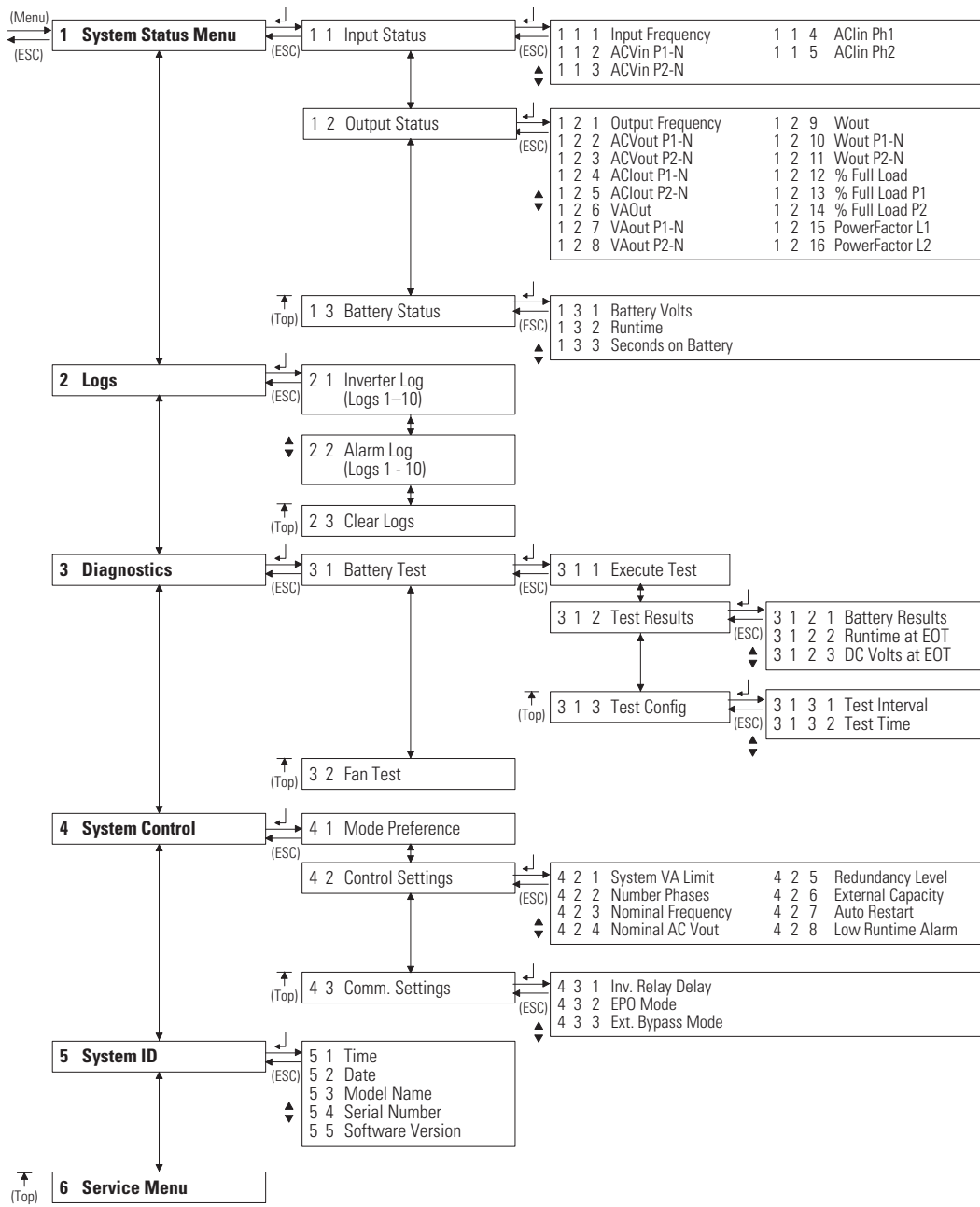

Figure 60. System Menu Map

Chapter 9 Communication

Eaton offers several methods of communicating with your Eaton 9170+ system in addition to the front panel display:

- Intelligent Power Manager® (IPM) Power Management Software
- PredictPulse™ Monitoring and Management Service
- Optional interface kits
- Communication slots
- Dedicated input signals
- DB-9 communication port

Intelligent Power Manager

The IPM is an environmental device supervision tool for IT environments. The Eaton IPM delivers a global view across the network from any PC with an Internet browser. Exceptionally versatile, the software is compatible with any device that supports a network interface, such as UPSs, environmental sensors, other manufacturer's Power Distribution Unit (PDU) or the Eaton Enclosure Power Distribution Unit (ePDU®), other manufacturer's UPSs, and applications. The Eaton IPM can also organize a management table by groups, centralize alarms, and maintain events logs for preventive maintenance of the entire installed equipment base.

PredictPulse

PredictPulse is a subscription monitoring and management service from Eaton that collects and analyzes data from connected power infrastructure devices, providing us with the insight needed to make recommendations and take action on your behalf. It's also powered by CA Technologies, bringing together the best in hardware and software. Like a second set of eyes on your power infrastructure, PredictPulse provides 24/7 remote monitoring of alarms and system performance (load, temperature/humidity, battery health, energy savings, and service level) to reduce downtime risk and expedite repairs.

PredictPulse also shares real-time status and trend information via an online dashboard and smartphone mobile app (Apple and Android), giving subscribers insights about past and current performance, a list of all active alarms, and asset management data (i.e., battery date codes, last and next scheduled service dates, firmware versions).

The service notifies customers of critical alarms, supports remote diagnostics, and facilitates smart dispatch of technicians. PredictPulse requires a gateway connectivity card (Power Xpert Gateway UPS [PXGX]) or a ConnectUPS™-BD Web/SNMP in an X-Slot communication bay and an Environmental Monitoring Probe (EMP) for battery temperature/humidity monitoring.

Optional Interface Kits

For computer systems that already have UPS monitoring software, Eaton offers interface cable kits for connecting the Eaton 9170+ system to your computer system. The kit includes the cable, adapters, and instructions.

Communication Slots

The Eaton 9170+ UPS has two communication slots that allow quick installation of the optional BestDock™ cards. These interface cards extend the capabilities of the Eaton 9170+ system to provide compatibility with network and remote monitoring/management systems.

ConnectUPS Web/SNMP Card (BD Model)

The ConnectUPS-BD Web/SNMP Card provides the Eaton 9170+ system with its own ethernet network connection, allowing it to be remotely monitored and controlled via industry-standard Internet browsers. The HTML interface enables UPS monitoring and management from anywhere on the Internet or within your intranet. In addition, third-party Simple Network Management Protocol (SNMP) software packages may also be used to communicate remotely with the Eaton 9170+ system.

The ConnectUPS-BD Web/SNMP Card also allows UPS-dependent computer systems to automatically shut down during extended power outages using *PredictPulse*.

Relay Interface Card (BestDock Model)

The BestDock Relay Interface Card provides true relay contact output to peripheral devices. Outputs are user-selectable as normally open or normally closed. Refer to the instructions included with the relay card for more detail.

Dedicated Input Signals

Emergency Power-off: Connection to a facility Emergency Shutdown switch provides a method for emergency Eaton 9170+ system shutdown. Opening this connection creates an immediate shutdown of the Eaton 9170+ UPS output.

Bypass: The signal from an external bypass switch, to isolate the Eaton 9170+ system for maintenance purposes, tells the UPS to go into Internal Bypass mode.

On-Generator: An external signal can indicate that the input power is being supplied by a generator. Closure of this contact causes the UPS to change the following parameters to preset values that are designed to optimize performance during periods of generator instability:

- Phase Lock Window and Frequency Slew Rate. These parameters increase the rate at which the UPS tracks the input line, which causes fewer recognized line faults during generator instability.
- Frequency Glitch Count. This parameter increases the number of bad frequency cycles before the unit transfers to battery power, allowing the UPS to operate smoothly during generator instability without transferring to battery.
- Maximum Delta and Line Delta. These parameters widen the acceptable input voltage range, allowing the UPS to ignore any transient voltage regulation problems a generator may experience during unstable periods.
- These parameters are also available to trained service personnel through the Service Menu.

See Figure 14 on page 20 and Figure 21 on page 24 to make the connection for all dedicated input signals.

DB-9 Communication Port

Table 13 explains the functions of the pins on the Eaton 9170+ DB-9 communication port. This port is on the Eaton 9170+ UPS rear panel, as shown in Figure 49 on page 52.

Table 13. DB-9 Port Signals

Pin	Function	Description
1	Low Battery Alarm	Pin 1 shifts from RS-232 Low (positive voltage) to RS-232 High (negative voltage) and remains high whenever the UPS enters a Low Battery alarm state.
2	RS-232 Transmit Data	Sends outgoing RS-232 communication data at 9600 baud, 8 bits, no parity, 1 stop bit.
3	RS-232 Receive Data/ RS-232 Shutdown	<p>RS-232 Receive Data Function. Receives incoming RS-232 communication data at 9600 baud, 8 bits, no parity, 1 stop bit.</p> <p>RS-232 Shutdown Function. If Pin 3 receives an RS-232 Low signal (+Vdc) for at least 5 seconds, but not more than 7 seconds, during an AC Failure condition, the UPS output shuts off following a delay of 120 seconds (± 5 seconds).</p> <ul style="list-style-type: none"> The UPS output shuts off even if the normal AC input power is restored during the 120 second delay. The UPS output automatically restarts after the UPS determines the normal AC input power is stable. The shutdown and restart timing represented by the functionality of Pin 3 is independent from the shutdown and restart timing specified from the host software.
4	Reserved	Loopback to Pin 6
5	Common	Signal Ground
6	Reserved	Loopback to Pin 4
7	No Connection	Open pin
8	AC Fail Signal (On-Battery)	<p>Pin 8 shifts from RS-232 Low (positive voltage) to RS-232 High (negative voltage) and remains high for 15 seconds (± 1 second) after the UPS detects an AC Failure condition, assuming the condition still exists after the 15 seconds.</p> <p>When the AC Failure condition no longer exists, the signal returns to the RS-232 Low state (positive voltage).</p>
9	No Connection/ DC Supply Voltage	<p>The UPS is factory-set with Pin 9 disconnected, but can be enabled through a technician-replaceable jumper inside the UPS. The jumper setting MUST be changed by a qualified service technician.</p> <p>When enabled, Pin 9 provides supply voltage for use with external connectivity devices requiring DC power directly from the UPS DB-9 port (nominal 12 Vdc/5W; 8V minimum, 24V maximum). Use only Eaton brand connectivity devices.</p>

Chapter 10 Maintenance

This chapter provides maintenance information.

Routine Maintenance

NOTE 1 Observe important safety precautions while performing these checks.



NOTE 2 Eaton recommends that you schedule preventive maintenance checks at least every six months.

The Eaton 9170+ system is designed to provide years of trouble-free operation. Its internal control system checks the batteries and inverter periodically to ensure reliable operation.

The Eaton 9170+ UPS and optional external battery cabinets do require some attention to assure continued reliable service. Follow Eaton's recommended maintenance schedule, which includes:

- Check operating environment for clean, cool, dry conditions.
- Inspect and clean the cabinet.
- Check operation of fans (power modules).
- Check and tighten all connections.
- View and record the alarm and inverter logs.
- Check the batteries.
- Check the displayed UPS readings against actual measurements and recalibrate if necessary.
- Perform a system test.
- Check and record the values of the parameters in the System Status Menu (menu 1) online and on battery.
- Check the MOV surge suppression pack.

For more information on preventive maintenance checks, contact your service representative.

Storage Temperature

Store the Eaton 9170+ battery modules (in the UPS or external battery cabinet) at -20 to $+40^{\circ}\text{C}$ (-4 to $+104^{\circ}\text{F}$). Batteries will have a longer shelf life if they are kept below $+25^{\circ}\text{C}$ ($+77^{\circ}\text{F}$). The Eaton 9170+ UPS or battery cabinet without batteries may be stored at -40 to $+60^{\circ}\text{C}$ (-40 to $+140^{\circ}\text{F}$).

External Bypass Switch (Make-Before-Break Only) Operation

Press the red button beside the switch before turning the Eaton MBB bypass switch. This button:

- Sends an electrical signal to the UPS to switch to the internal Bypass mode (if it is not already operating in that mode).
- Operates a mechanical interlock, to prevent the switch from being turned without first signaling the UPS.



NOTE When the red button is released, the UPS remains in its internal Bypass mode. Return the UPS to Auto mode by selecting that mode on the front panel display.

See "Bypass Switch Operation" on page 17 for additional information.

Battery Replacement

The Eaton 9170+ hot-swappable feature lets you replace the battery modules without disconnecting the load or damaging the batteries.

	NOTE The Eaton 9170+ UPS will operate with uncharged (or no) batteries, but will have limited (or no) battery backup capability. Backup protection requires at least three battery strings for every four power modules. The UPS may indicate an alarm with no batteries present.
---	--

To replace battery modules in pairs:

1. Remove the front covers from the battery modules to replace.
The covers have spring latches on the left and right sides that hold them in place.
2. Grasp the battery module handle and press down on the latch release.
3. Pull the module out approximately 17 cm (7") to the secondary stop on top of the module.
4. Press down on the secondary stop release, pull the module out farther, and support the module weight with your second hand as you remove the module from the cabinet.
5. Remove the battery module beside the first in a similar manner. Label the original modules with masking tape or some other identifier.
6. After removing a pair (one string) of battery modules, install a replacement pair. Replacements may be installed in empty cabinet slots before removing the original battery modules.
7. When all desired battery modules have been replaced, replace the front cover(s).
8. If the batteries are not properly installed, the Open Cell alarm activates. Check the batteries in the slot indicated on the alarm screen.

Power Module Replacement

The Eaton 9170+ hot-swap feature lets you replace a power module without disconnecting the load or damaging the UPS.

	NOTE The UPS may switch to internal Bypass mode if the remaining power modules are insufficient to supply the required power. If empty slots exist, install replacement modules before removing original ones.
---	---

Use care in removing and installing power modules. To remove a power module:

1. Remove the front cover.
The cover has spring latches on the left and right sides that hold it in place.
2. Loosen the thumbscrew on the module handle. Press down on the latch release at the center of the module handle and pull the handle down.
As the module handle fully extends, the module disconnects. Slide the module slowly out of the cabinet.
3. Use two hands to support the module. When fully extended, lower the front down slightly and lift the rear edge over the safety stop on the center support rail.
4. Treat the original and replacement modules with care to avoid damaging connectors or internal circuitry. Label the original module with masking tape or some other identifier. Record the serial number of the replacement module for your warranty.

5. Insert the replacement module by sliding it carefully into the cabinet. Lower the front down slightly and lift the rear edge over the safety stop on the center support rail. Keep the module handle extended until the module is fully inserted.
6. Raise the power module handle to secure the module into the cabinet. Be sure the handle latch snaps into place. Tighten the thumbscrew on the handle.
7. Replace the front cover.

Chapter 11 Specifications

This section provides the following specifications for the Eaton 9170+ models:

- Electrical input and output
- Isolation
- Model specifications
- Environmental and safety
- Battery
- Weights and dimensions

Table 14. Electrical Input and Output

Nominal Input Voltage	200–240 Vac or 100/200, 110/220, 120/208, 120/240, 127/220 Vac
Input Voltage Range	176–276 Vac*
Nominal Output Voltage	200–240 Vac or 100/200, 110/220, 120/208, 120/240, 127/220 Vac
Nominal Frequency	Online: 50/60 Hz auto-sensing; output frequency tracks input frequency to selectable limit (± 0.1 to ± 5.0 Hz; ± 3.0 Hz default); switches to battery operation outside this tolerance On battery: 50 Hz or 60 Hz ± 0.1 Hz
Regulation	$\pm 3\%$ load regulation (under any line, load, or battery condition)
Voltage Waveform	Sine wave; $<3\%$ THD at rated linear loads, computer-grade power
Overload Capability	150% for 10 seconds; 300% for 12 cycles
DC Input Protection	DC fuse and battery charger overvoltage limit network
Output Protection	Microprocessor-sensed overvoltage and overcurrent, with fuse backup
Efficiency in Double-Conversion mode	$>88\%$
Efficiency in Double-Conversion mode (with Isolated Output)	$>84\%$
Efficiency in Bypass mode (with Isolated Output)	$>96\%$

* 176–250 Vac for universal power modules producing 200 and 208 Vac nominal output voltage. 152–239 Vac for 120/208 and 127/220.

Table 15. Isolation

Models 0650C and 0660C Output Neutral-to-Ground Bonding	$\pm 3\%$ load regulation (under any line, load, or battery condition) Neutral is carried through from input to output; a separate neutral-to-ground bond is not required.
Models 0650I, 0660I, and 0660J Isolation, Including Output Neutral-to-Ground Bonding	True, separately derived power source as defined by National Electrical Code (NEC) Article 250-5d, with output neutral bonded to ground. No direct connection between input and output; neutral-to-ground bond is required; other local codes may take precedence.

Table 16. Split-Phase Model Specifications (ASY-0673)

3 kVA, 2500 Watts				
Voltage	Input Current*	Output Current	Input Service*	Heat Dissipation Normal Mode
200	16A	15A	25A	285W (0.98 kBTU/hr)
220	15A	14A		
208	14A	14.5A		
220	13A	14A		
230	14.5A	13A		
240	14A	12.5A		
6 kVA, 5000 Watts				
Voltage	Input Current*	Output Current	Input Service*	Heat Dissipation Normal Mode
200	32A	30A	40A	570W (1.95 kBTU/hr)
220	30A	28A		
208	28A	29A		
220	26A	28A		
230	29A	26A		
240	28A	25A		
9 kVA, 7500 Watts				
Voltage	Input Current*	Output Current	Input Service*	Heat Dissipation Normal Mode
200	48A	45A	60A	860W (2.93 kBTU/hr)
220	45A	42A		
208	42A	43.5A		
220	39A	42A		
230	43.5A	39A		
240	42A	37.5A		
12 kVA, 10000 Watts				
Voltage	Input Current*	Output Current	Input Service*	Heat Dissipation Normal Mode
200	64A	60A	80A	1145W (3.90 kBTU/hr)
220	60A	56A		
208	56A	58A		
220	52A	56A		
230	58A	52A		
240	56A	50A		

Table 16. Split-Phase Model Specifications (ASY-0673) (Continued)

15 kVA, 12500 Watts				
Voltage	Input Current*	Output Current	Input Service*	Heat Dissipation Normal Mode
200	80A	75A	100A	1430W (4.88 kBTU/hr)
220	75A	70A		
208	70A	72.5A		
220	65A	70A		
230	72.5A	65A		
240	70A	62.5A		
18 kVA, 15000 Watts				
Voltage	Input Current*	Output Current	Input Service*	Heat Dissipation Normal Mode
200	96A	90A	125A	1720W (5.85 kBTU/hr)
220	90A	84A		
208	84A	77A		
220	78A	84A		
230	87A	78A		
240	84A	75A		

* In High-Efficiency and Bypass modes the input current equals the output current plus 2A for each power module in the system.
For redundant power module operation (N+X), increase the input current rating by 2A for each additional redundant power module.

Table 17. Universal Model Specifications (ASY-0674)

3 kVA, 2100 Watts				
Voltage	Input Current*	Output Current	Input Service*	Heat Dissipation Normal Mode
200	14A	15A	25A	285W (0.98 kBTU/hr)
208	13.5A	14.5A		
220	13A	14A		
230	12.5A	13A		
240	12A	12.5A		
6 kVA, 4200 Watts				
Voltage	Input Current*	Output Current	Input Service*	Heat Dissipation Normal Mode
200	28A	30A	40A	570W (1.95 kBTU/hr)
208	27A	29A		
220	26A	28A		
230	25A	26A		
240	24A	25A		

Table 17. Universal Model Specifications (ASY-0674) (Continued)

9 kVA, 6300 Watts				
Voltage	Input Current*	Output Current	Input Service*	Heat Dissipation Normal Mode
200	42A	45A	60A	860W (2.93 kBTU/hr)
208	40.5A	43.5A		
220	39A	42A		
230	37.5A	39A		
240	36A	37.5A		
12 kVA, 8400 Watts				
Voltage	Input Current*	Output Current	Input Service*	Heat Dissipation Normal Mode
200	56A	60A	80A	1145W (3.90 kBTU/hr)
208	54A	58A		
220	52A	56A		
230	50A	52A		
240	48A	50A		
15 kVA, 10500 Watts				
Voltage	Input Current*	Output Current	Input Service*	Heat Dissipation Normal Mode
200	70A	75A	100A	1430W (4.88 kBTU/hr)
208	67.5A	72.5A		
220	65A	70A		
230	62.5A	65A		
240	60A	62.5A		
18 kVA, 12600 Watts				
Voltage	Input Current*	Output Current	Input Service*	Heat Dissipation Normal Mode
200	84A	90A	125A	1720W (5.85 kBTU/hr)
208	81A	87A		
220	78A	84A		
230	75A	78A		
240	72A	75A		

* In High-Efficiency and Bypass modes the input current equals the output current plus 2A for each power module in the system. For redundant power module operation (N+X), increase the input current rating by 2A for each additional redundant power module.

Table 18. Environmental and Safety

Operating Temperature	0°C to 40°C (32°F to 104°F) Optimal battery performance: 25°C (77°F)
Storage Temperature	UPS with battery modules: –20°C to +40°C (–4°F to 104°F) UPS without batteries: –40°C to +60°C (–40°F to 140°F)
Relative Humidity	5–95% noncondensing
Operating Altitude	Up to 3,050 meters above sea level (10,000 ft) The maximum operating ambient temperature decreases 1°C per 300m above 1525m (2°F per 1000 ft above 5000 ft)
Non-Operating Altitude	Up to 12,200m above sea level (40,000 ft)
Ventilation	The air around the UPS must be clean and free of dust, corrosive chemicals, and other contaminants. The Eaton 9170+ UPS uses internal fans to circulate the air for cooling. The air must be free to circulate around the UPS and battery cabinet(s). Do not operate the UPS in a sealed room or container.
Audible Noise	Less than 53 dBA
Surge Suppression	ANSI C62.41 Category B (formerly IEEE 587); IEC 61000-4-5
Safety Conformance	CAN/CSA C22.2, No. 107.1; UL 1778; IEC 62040-1 and IEC 60950
Agency Markings	UL, cUL, TÜV, CE, C-Tick, BCIQ
EMC (Class A)	IEC 62040-2, FCC Part 15, ICES-003, VCCI

Table 19. Battery

Configuration	(2) 60V, 7.2 Ah batteries per string
Voltage	120 Vdc
Type	Sealed, maintenance-free, valve-regulated, lead-acid
Charging	Recharge time: 4 hr after full-load resistive discharge; 8 hr after half-load resistive discharge, using standard internal battery charger. Optional battery chargers at higher current ratings will be available for future product release.

Table 20. Weights and Dimensions

Cabinet Size	Height	Width	Depth	Weight*
3-slot	45 cm (17.75")	43 cm (17.0")	65 cm (25.5")	30 kg (66 lb)
3-slot (with caster cart)	49.5 cm (19.5")	43 cm (17.0")	65 cm (25.5")	35 kg (78 lb)
6-slot	80 cm (31.5")	43 cm (17.0")	65 cm (25.5")	47 kg (103 lb)
6-slot (with caster cart)	84.5 cm (33.25")	43 cm (17.0")	65 cm (25.5")	52 kg (115 lb)
9-slot	119.5 cm (47.0")	61 cm (24.0")	72.5 cm (28.5")	72 kg (158 lb)
12-slot	154.5 cm (60.75")	61 cm (24.0")	72.5 cm (28.5")	89 kg (196 lb)

* Add the following weights for isolation transformers:

3-slot cabinet: 30 kg (66 lb)

6-slot cabinet: 64 kg (140 lb)

12-slot cabinet: 125 kg (275 lb)

Optional floor anchor kit weighs 4 kg (9 lb)

Each battery module weighs 14 kg (30 lb)

Each power module weighs 8 kg (17 lb)

Specifications



Chapter 12 Troubleshooting

The following table provides answers to commonly asked questions.

Table 21. Frequently Asked Questions

Question: How do I...	Answer
Turn the UPS on?	<p>Verify that all power modules are securely plugged into the cabinet, and each module handle is latched.</p> <p>If external battery cabinets are installed, confirm that the DC emergency disconnect switch button on the back of the cabinet is closed (pulled out). To close the DC emergency disconnect switch button, insert the switch key supplied with the cabinet into the button and turn clockwise 1/2-turn. Pull the button out to close the switch. Turn the key back counter-clockwise, and remove the key.</p> <p>If an external bypass switch is installed, turn the switch to the LINE or UPS position.</p> <p>Refer to the front panel display and press the button labeled ON. (If On/Off control is password-protected, enter the user password: 0377.) Confirm the selection by pressing the button labeled Yes. After a few seconds, the green LED illuminates to signal the UPS is operating and producing power.</p>
Turn the UPS off?	<p>Refer to the front panel display and press the button labeled OFF. Confirm the selection by pressing the button labeled Yes. (If On/Off control is password-protected, enter the user password: 0377.)</p> <p>In the event of a front panel display failure, you can turn the unit on or off using a computer connected to the communication port.</p> <p>In an emergency or when the above two methods fail to turn the unit off, remove the front covers, and unlatch and pull the handles of all power modules out at least 2.5 cm (1") to turn off the power control circuitry. If your UPS has external battery cabinets, push in the DC emergency disconnect switch button on the back of the battery cabinet nearest to the UPS cabinet.</p>
Turn off the alarm beeps?	<p>Press the lower left button on the front panel display. Note the alarm message and see "Alarms" on page 82 to correct the problem. After the problem has been resolved, press the lower center button to clear the alarm.</p>
View the alarm log?	<p>Go to menu 2 2. Press \leftarrow the button to view the most recent alarm. Press the \blacktriangledown button to scroll down through the log to view previous alarms.</p>
Check the input or output voltage?	<p>Go to menus 1 1 2 and 1 1 3 for the input voltage; go to menus 1 2 2 and 1 2 3 for the output voltage.</p>
Check the battery voltage?	<p>Go to menu 1 3 1. To view other system status parameters, see "Menu Map" on page 65</p>
Check the condition of the batteries?	<p>The results of the most recent battery test are stored at menu 3 1 2 1. To run a test of battery condition, go to menu 3 1 1 and press the \leftarrow button. When the test is complete, the results are again stored in the Battery Results parameter.</p>
Change the battery low-voltage alarm threshold? (or any other alarm or operating limit?)	<p>This parameter requires a trained person, knowing the correct password, to perform. Without the proper password, you are able to only view operating limits, not change them. Only authorized personnel should change these limits. For information about making this or other password-protected adjustments, contact your service representative.</p>
Apply power to the load if the unit will not operate?	<p>Turn the optional external bypass switch to either the SERVICE or the LINE position. In these two positions, utility power flows directly to the load. In the SERVICE position, the UPS does not receive utility power and may be worked on for maintenance purposes.</p>
Turn the external bypass switch?	<p>If the bypass switch is a Make-Before-Break type, you must press the red button beside the switch before turning the switch.</p>
Set the UPS to turn on in High Efficiency mode?	<p>Go to menu 4 1. Select the system mode desired at power-on by pressing the \blacktriangle or \blacktriangledown button. When the display shows Auto High Efficiency, press the button \leftarrow.</p>

Table 21. Frequently Asked Questions (Continued)

Question: How do I...	Answer
Set the UPS to operate in High Efficiency mode on weekends?	The Eaton 9170+ system will not change operating modes as a timed event. But, if you wish to conserve energy, before leaving for the weekend, go to menu 4 1. Select High Efficiency and press the  button. After the weekend, return to the Automatic mode by going to menu 4 1 again, and selecting Auto followed by pressing the  button.
Change the level of system redundancy?	To view or change the redundancy level, go to menu 4 2 5.
Change the batteries?	Each side-by-side pair of battery modules forms one series string on the battery bus. See "Battery Replacement" on page 72 for the battery replacement procedure.
Add/delete one or more strings of batteries?	Physically install or remove battery modules as described on page 51. Record capacity of external battery strings (in all external battery cabinets) by going to menu 4 2 6.
Add/delete one or more power modules?	Physically install or remove power modules as described on page 51. The system operating software senses the number and location of all power modules in the cabinet. If you want to change the number of redundant power modules, go to menu 4 2 5 and change the level of system redundancy.

Alarms

Figure 61 shows a typical alarm display. Alarms are annunciated by a constant Alarm LED and a constant beep. During alarm display, button (A) silences the audible alarm, button (B) clears the alarm display, and button (C) performs the normal Escape function to exit from the alarm display. The  button lets you scroll through all alarms.

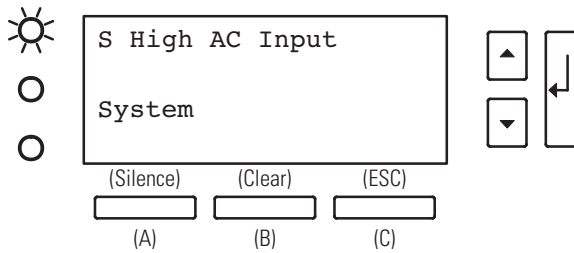

Figure 61. Typical System Active Alarm Display

Figure 62 shows a detailed alarm entry. Some alarms provide additional information on the second line of the display to help identify the cause of the alarm. The third line may also display a specific slot number where the fault occurred. If the alarm is not specific to a slot number, "System" appears on the display.

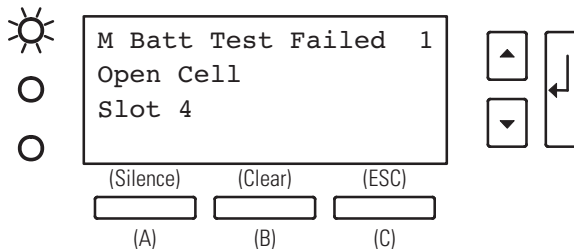

Figure 62. Detailed Alarm Entry

When the Eaton 9170+ UPS detects an alarm condition, the UPS displays the alarm with the following indications:

- Illuminates the red LED next to the front panel display
- Sounds an audible alarm
- Displays an alarm message

When an alarm occurs, follow these steps:

1. Observe the display to see which alarm is active.

NOTE To find out if more than one alarm is active, press \leftarrow . This switches the display between alarm messages. To silence the audible alarm, press button (A) below the display.

2. Find the alarm message in Table 22 or Table 23 and follow the instructions to resolve the problem. To clear an alarm after resolving the problem, press button (B) below the display. If the problem is still present, the alarm will sound again after a short delay.

Table 22 contains descriptions of critical alarm messages. Critical alarms require immediate operator attention and corrective action.

Table 22. Critical Alarm Messages

Alarm Message	What It Means	What to Do
A Low Battery	The UPS has shut down after running on battery and discharging the batteries.	Wait for AC input power to be restored. When AC input power returns, the UPS begins recharging batteries and applies power to the load.
C High Battery	The battery voltage is too high because of a charger problem, battery problem, or incorrect parameter setting.	Contact your service representative.
E Low AC Output	The UPS has shut down because the AC output voltage is too low to provide power to the load.	Contact your service representative.
F High AC Output	The UPS has shut down because the AC output voltage is too high.	Contact your service representative.
S High AC Input	The AC input voltage is too high; any further increase to the voltage may damage the UPS.	This alarm automatically clears when input voltage returns to normal limits. The UPS will continue to support the load until the batteries are depleted.
G Output Overload	The load is requiring more power than the UPS power modules are capable of supplying, and the UPS has switched to Bypass mode.	Switch off your equipment one piece at a time until the alarm stops.
I Overload Shutdown	The UPS has shut down due to excessive load.	Remove excess load(s) from the UPS output and restart the UPS by pressing the ON button through the front panel display.
H High Heatsink Temperature	The inverter temperature is too high. If the temperature reaches a preset limit, the unit will shut down.	If the UPS has not shut down, bypass the UPS or shut down your equipment, and turn the UPS off. Contact your service representative.
P EPO	The emergency power-off (EPO) function has been activated.	Deactivate the external EPO switch and restart the UPS by pressing the ON button through the front panel display.
T Call Service	The UPS has detected a problem that requires service.	Contact your service representative.

Table 22. Critical Alarm Messages (Continued)

Alarm Message	What It Means	What to Do
T Call Service Phase Error	The UPS has detected the input phase rotation to be incompatible with its output wiring and will not start up.	Correct the input wiring problem and restart the UPS.
T Call Service Module Failure	A power module has detected an internal fault and has shut down.	Look for the slot number (third line on display) of the power module and replace the defective module.
T Call Service Module Handle Open (firmware versions 2.22 and later)	The UPS has detected an open power module handle.	Look for the slot number (third line on display) of the power module and close the handle.
T Call Service Excessive Transfers	The UPS has detected an excessively high number of automatic transfers from High Efficiency mode, and has switched to Double Conversion (Auto) mode.	Contact your service representative.
T Call Service Precharge Failure	A power module has detected an initialization sequence problem and will not start up.	Look for the slot number (third line on display) of the affected module. Contact your service representative.
T Call Service Incompatible Module	A power module with incompatible firmware has been installed in the system.	Look for the slot number (third line on display) of the affected module. Contact your service representative.
5 Fan Failure	The UPS has detected a module fan problem that requires service.	Contact your service representative.

Table 23 contains descriptions of non-critical alarm messages. Non-critical alarms are not as urgent as critical alarms, but should be attended to as soon as convenient to avoid the problem becoming critical.

Table 23. Non-Critical Alarm Messages

Alarm Message	What It Means	What to Do
B Near Low Battery	The battery voltage has reached the Near Low Battery set point.	If the voltage increases, the alarm clears automatically. If it drops further, it will cause a Low Battery alarm.
D Low Runtime	Batteries in the cabinet are nearly discharged.	Perform an orderly shutdown of all equipment and wait for AC input power to return. When AC input power returns, the UPS begins recharging batteries and automatically restarts.
O Check Memory	The configuration as stored in the system memory may have been corrupted.	Look for the slot number (third line on display) of the failed module. Contact your service representative.
M Check Battery	The batteries have failed an automatic system test.	Contact your service representative.
M Check Battery Open Cell	A battery (pair of modules) has failed an open cell test.	Look for the slot number (third line on display) of the failed modules. Verify that both battery modules are properly installed. If properly installed, replace both battery modules.
M Check Battery Weak Battery	The system batteries have degraded to the point where system runtime is less than the designed rating.	Replace all battery modules.

Table 23. Non-Critical Alarm Messages (Continued)

Alarm Message	What It Means	What to Do
U Low Redundancy	The number of active power modules is too low to provide the programmed redundancy level to protect the current load.	The unit is able to protect the equipment, but will not be fault tolerant. To regain the desired redundancy, either add power modules or reduce the load.
U Low Redundancy Insufficient Batteries	The UPS load exceeds 2800 watts per battery string. The system will protect the load during short power outages, but battery degradation or damage may result.	Reduce the load or install additional battery modules (two modules per string).
U Low Redundancy Insufficient Modules	The number of active power modules is too few to provide the programmed redundancy level while protecting the load. The UPS will protect the load, but will not be fault tolerant.	Reduce the load or install additional power modules.

Service and Support

If you have any questions or problems with the UPS, call your **Local Distributor** or the **Help Desk** at one of the following telephone numbers and ask for a UPS technical representative.

United States: **1-800-356-5737**
 Canada: **1-800-461-9166 ext 260**
 All other countries: **Call your local service representative**

Please have the following information ready when you call the Help Desk:

- Model number
- Serial number
- Version number (if available)
- Date of failure or problem
- Symptoms of failure or problem
- Customer return address and contact information

If repair is required, you will be given a Returned Material Authorization (RMA) Number. This number must appear on the outside of the package and on the Bill Of Lading (if applicable). Use the original packaging or request packaging from the Help Desk or distributor. Units damaged in shipment as a result of improper packaging are not covered under warranty. A replacement or repair unit will be shipped, freight prepaid for all warrantied units.



NOTE For critical applications, immediate replacement may be available. Call the **Help Desk** for the dealer or distributor nearest you.

Chapter 13 Warranty

Two-Year Limited Warranty (US and Canada)

Eaton UPS Models: 9155, 9170+ and FERRUPS® 4.3–18 kVA

WARRANTOR: The warrantor for the limited warranties set forth herein is Eaton (“Company”).

LIMITED WARRANTY: This limited warranty (this “Warranty”) applies only to the original End-user (the “End-user”) of any 9155, 9170 and FERRUPS 4.3–18 kVA Products (individually and collectively, the “Product”) purchased on or after June 1, 2004, and cannot be transferred. This Warranty applies even in the event that the Product is initially sold by Company for resale to an End-user.

LIMITED WARRANTY PERIOD: The period covered by this Warranty for Product installed [and currently located] in the fifty (50) United States, the District of Columbia and Canada is twenty-four (24) months from the date of purchase for parts, or thirty (30) months from the date of shipment for parts, and ninety (90) days from the date of purchase for labor, as further clarified in the following sections.

WHAT THIS LIMITED WARRANTY COVERS: The warrantor warrants that the Product and battery (individually and collectively, the “Warranted Items”) are free of defects in material and workmanship. If, in the opinion of Company, a Warranted Item is defective and the defect is within the terms of this Warranty, Company’s sole obligation will be to repair or replace such defective Warranted Items (including by providing service, parts and labor, as applicable), at the option of Company, and such repair or replacement shall be at either the End-user’s location, Company’s site, or such other location as determined by Company. All Warranted Items returned to Company and all parts replaced by Company shall become the property of Company. Expenses for any labor to repair the Warranted Item beyond the initial ninety (90) days are the sole responsibility of the End-user.

PROCEDURES FOR REPAIR OR REPLACEMENT OF WARRANTED ITEMS: When shipment is required of End-user: When Company determines that the Warranted Item will be repaired or replaced at a Company site or such other location, and the End-user must ship to Company the defective Warranted Item, the following procedures are required.

If the Warranted Item is to be replaced by Company, and the End-user supplies a credit card number or purchase order for the value of the replacement product, Company will use commercially reasonable business efforts to ship (via standard ground shipment and at no cost to the End-user) the replacement Warranted Item to the End-user within one (1) business day after Company receives notice of the warranty claim. In such case, the End-user must return (at Company’s expense) the defective Warranted Item to Company in the same packaging as the replacement Warranted Item received by the End-user or as otherwise instructed by Company. If Company does not receive the defective Warranted Item, Company will either charge the End-user’s credit card, or send the End-user an invoice (which the End-user agrees to pay), for the value of the replacement product.

If the Warranted Item is to be replaced by Company, but the End-user is unwilling or unable to supply a credit card number or purchase order for the value of the replacement product, Company will use commercially reasonable business efforts to ship (via standard ground shipment and at no cost to the End-user) the replacement Warranted Item to the End-user within one (1) business day after Company receives the defective product from the End-user.

In any case, Company will provide shipping instructions and will pay its designated carrier for all shipping charges for return of defective equipment and replacement of Warranted Items. Any returned Warranted Item or parts that are replaced may be new or reconditioned. All Warranted Items returned to Company and all parts replaced by Company shall become the property of Company.

WHAT THIS LIMITED WARRANTY DOES NOT COVER: This Warranty does not cover any defects or damages caused by: (a) failure to properly store the Product before installation, including the charge of batteries no later than the date indicated on the packaging; (b) shipping and delivery of the Product if shipping is FOB Factory; (c) neglect, accident, abuse, misuse, misapplication or incorrect installation; (d) repair or alteration not authorized in writing by Company personnel or performed by an authorized Company Customer Service Engineer or Agent; (e) improper testing, operation, maintenance, adjustment or modification of any kind not authorized in writing by Company personnel or performed by an authorized Company Customer Service Engineer or Agent; or (f) use of the Product under other than normal operating conditions or in a manner inconsistent with the Product's labels or instructions.

This Warranty is not valid if the Product's serial numbers have been removed or are illegible. Any Warranted Items repaired or replaced pursuant to this Warranty will be warranted for the remaining portion of the original Warranty subject to all the terms thereof.

Company shall not be responsible for any charges for testing, checking, removal or installation of Warranted Items.

COMPANY DOES NOT WARRANT EQUIPMENT NOT MANUFACTURED BY COMPANY. IF PERMITTED BY THE APPLICABLE MANUFACTURER, COMPANY SHALL PASS THROUGH SUCH MANUFACTURER'S WARRANTIES TO END-USER.

COMPANY DOES NOT WARRANT SOFTWARE, INCLUDING SOFTWARE EMBEDDED IN PRODUCTS, THAT IS NOT CREATED BY COMPANY. WITHOUT LIMITING THE FOREGOING, COMPANY SPECIFICALLY DOES NOT WARRANT SOFTWARE (SUCH AS LINUX) THAT WAS CREATED USING AN "OPEN SOURCE" MODEL OR IS DISTRIBUTED PURSUANT TO AN OPEN SOURCE LICENSE.

THIS WARRANTY IS THE SOLE AND EXCLUSIVE WARRANTY OFFERED BY COMPANY WITH RESPECT TO THE PRODUCTS AND SERVICES AND, EXCEPT FOR SUCH FOREGOING WARRANTY COMPANY DISCLAIMS ALL OTHER WARRANTIES INCLUDING BUT NOT LIMITED TO ANY IMPLIED WARRANTIES OF MERCHANTABILITY, TITLE, NON-INFRINGEMENT AND FITNESS FOR A PARTICULAR PURPOSE. CORRECTION OF NON-CONFORMITIES IN THE MANNER AND FOR THE PERIOD OF TIME PROVIDED ABOVE SHALL CONSTITUTE COMPANY'S SOLE LIABILITY AND END-USER'S EXCLUSIVE REMEDY FOR FAILURE OF COMPANY TO MEET ITS WARRANTY OBLIGATIONS, WHETHER CLAIMS OF THE END-USER ARE BASED IN CONTRACT, IN TORT (INCLUDING NEGLIGENCE OR STRICT LIABILITY), OR OTHERWISE.

LIMITATION OF LIABILITY: The remedies of the End-user set forth herein are exclusive and are the sole remedies for any failure of Company to comply with its obligations hereunder. In no event shall Company be liable in contract, in tort (including negligence or strict liability) or otherwise for damage to property or equipment other than the Products, including loss of profits or revenue, loss of use of Products, loss of data, cost of capital, claims of customers of the End-user or any special, indirect, incidental or consequential damages whatsoever. The total cumulative liability of Company hereunder whether the claims are based in contract (including indemnity), in tort (including negligence or strict liability) or otherwise, shall not exceed the price of the Product on which such liability is based.

Company shall not be responsible for failure to provide service or parts due to causes beyond Company's reasonable control.

END-USER'S OBLIGATIONS: In order to receive the benefits of this Warranty, the End-user must use the Product in a normal way; follow the Product's operation and maintenance manual; and protect against further damage to the Product if there is a covered defect.

OTHER LIMITATIONS: Company's obligations under this Warranty are expressly conditioned upon receipt by Company of all payments due to it (including interest charges, if any). During such time as Company has not received payment of any amount due to it for the Product, in accordance with the contract terms under which the Product is sold, Company shall have no obligation under this Warranty. Also during such time, the period of this Warranty shall continue to run and the expiration of this Warranty shall not be extended upon payment of any overdue or unpaid amounts.

COSTS NOT RELATED TO WARRANTY: The End-user shall be invoiced for, and shall pay for, all services not expressly provided for by the terms of this Warranty, including without limitation, site calls involving an inspection that determines no corrective maintenance is required. Any costs for replacement equipment, installation, materials, freight charges, travel expenses or labor of Company representatives outside the terms of this Warranty will be borne by the End-user.

OBTAINING WARRANTY SERVICE: In the USA, call the Customer Reliability Center 7x24 at 800-356-5737. Outside of the USA, contact your local Eaton product sales or service representative for units purchased from those countries, or call the Customer Reliability Center in the USA at 919-845-3683 for units purchased in the USA that were shipped overseas. For comments or questions about this Warranty, write to the Customer Quality Representative, 8609 Six Forks Road, Raleigh, North Carolina 27615 USA.

Load Protection Guarantee (US and Canada)

Eaton UPS Models 3105, 3S, 5S, 5SC, 5110, 5115, 5125, 5P, 5PX, 9130, 9135, 9140, 9PX, 9155, 9170+, and FERRUPS GUARANTOR: The Guarantor for the load protection guaranty set forth herein is Eaton ("Company").

LIMITED GUARANTY: This load protection guaranty (this "Guaranty") applies only to the original End-user (the "End-user") of any Eaton 3105, 3S, 5S, 5SC, 5110, 5115, 5125, 5P, 5PX, 9130, 9135, 9140, 9PX, 9155, 9170+, and FERRUPS Products (individually and collectively, the "Product") and cannot be transferred. This Guaranty applies even in the event that the Product is initially sold by Company for resale to an End-user.

WHAT THIS GUARANTY COVERS: For the lifetime of the Product, Guarantor promises to repair or replace, at Guarantor's option, the equipment (valued up to the limits shown below*) that is damaged by an AC power line surge, spike, or other transient when properly connected to Guarantor's uninterruptible power system ("UPS"). Reimbursement for or restoration of data loss excluded. This Guaranty applies only if all of the following circumstances arise:

1. The UPS is plugged into properly grounded and wired outlets, using no extension cords, adapters, other ground wires, or other electrical connectors;
2. The installation of the UPS complies with all applicable electrical and safety codes described by the National Electrical Code (NEC);
3. The UPS was used under normal operating conditions and in accordance with all labels and instructions; and
4. The UPS was not damaged by accident (other than AC power line transient), misuse, or abuse.

***Cumulative Limits to be paid by Guarantor under this Load Protection Guaranty:**

- \$25,000 for Eaton UPS Model 3105 and 3S
- \$150,000 for Eaton UPS Models 5S, 5SC, 5110, 5115, 5125, 5P, and 5PX
- \$250,000 for Eaton UPS Models 9130, 9135, 9140, 9PX, 9155, 9170+, and FERRUPS products

WHAT THIS GUARANTY DOES NOT COVER: Any reimbursement or repair to End-user's equipment does not include reimbursement for or restoration of any data loss. This Guaranty does not cover any defects or damages caused by: (a) failure to properly store the Product before installation, including the charge of batteries no later than the date indicated on the packaging; (b) shipping and delivery of the Product if shipping is FOB Factory; (c) neglect, accident, abuse, misuse, misapplication, or incorrect installation of Product; (d) repair or alteration of Product not authorized in writing by Company personnel or performed by an authorized Company Customer Service Engineer or Agent; (e) improper testing, operation, maintenance, adjustment, or modification of any kind to the Product not authorized in writing by Company personnel or performed by an authorized Company Customer Service Engineer or Agent; or (f) use of the Product under other than normal operating conditions or in a manner inconsistent with the Product's labels or instructions.

This Guaranty is not valid: (a) unless the End-user returns to Company the Warranty Registration Card or completes the registration form on www.powerquality.eaton.com/productregistration within thirty (30) days of purchase; or (b) if the Product's serial numbers have been removed or are illegible.

Company shall not be responsible for any charges for testing, checking, removal, or installation of any items.

LIMITATION OF LIABILITY: THE REMEDIES OF THE END-USER SET FORTH HEREIN ARE EXCLUSIVE AND ARE THE SOLE REMEDIES FOR ANY FAILURE OF COMPANY TO COMPLY WITH ITS OBLIGATIONS HEREUNDER. EXCEPT AS OTHERWISE PROVIDED FOR IN THIS GUARANTY, IN NO EVENT SHALL COMPANY BE LIABLE IN CONTRACT, IN TORT (INCLUDING NEGLIGENCE OR STRICT LIABILITY) OR OTHERWISE FOR DAMAGE TO PROPERTY OR EQUIPMENT OTHER THAN THE PRODUCTS, INCLUDING LOSS OF PROFITS OR REVENUE, LOSS OF USE OF PRODUCTS, LOSS OF DATA, COST OF CAPITAL, CLAIMS OF CUSTOMERS OF THE END-USER OR ANY SPECIAL, INDIRECT, INCIDENTAL, OR CONSEQUENTIAL DAMAGES WHATSOEVER. THE TOTAL CUMULATIVE LIABILITY OF COMPANY HEREUNDER WHETHER THE CLAIMS ARE BASED IN CONTRACT (INCLUDING INDEMNITY), IN TORT (INCLUDING NEGLIGENCE OR STRICT LIABILITY) OR OTHERWISE, SHALL NOT EXCEED THOSE SET FORTH ABOVE.

Company shall not be responsible for failure to provide repair or replacement under this Guaranty due to causes beyond Company's reasonable control.

END-USER'S OBLIGATIONSS: In order to receive the benefits of this Guaranty, the End-user must use the Product in a normal way; follow the Product's operation and maintenance manual; and protect against further damage to the Product if there is a covered defect.

OTHER LIMITATIONS: Company's obligations under this Guaranty are expressly conditioned upon receipt by Company of all payments due to it (including interest charges, if any). During such time as Company has not received payment of any amount due to it for the Product, in accordance with the contract terms under which the Product is sold, Company shall have no obligation under this Guaranty.

COSTS NOT RELATED TO GUARANTY: The End-user shall be invoiced for, and shall pay for, all services not expressly provided for by the terms of this Guaranty, including without limitation, site calls involving an inspection that determines no corrective maintenance is required. Any costs for replacement equipment, installation, materials, freight charges, travel expenses, or labor of Company representatives outside the terms of this Guaranty will be borne by the End-user.

TO MAKE A CLAIM: In the USA, call the Customer Reliability Center 7x24 at 800-356-5737. Outside of the USA, contact your local Eaton product sales or service representative for units purchased from those countries, or call the Customer Reliability Center in the USA at 919-845-3683 for units purchased in the USA that were shipped overseas. For comments or questions about this Load Protection Guaranty, write to the Customer Quality Representative, 8609 Six Forks Road, Raleigh, North Carolina 27615 USA.