

Eaton® 9155 UPS

UPS-Mounted Bypass Switch
User's Guide



p/n: 164201644
Revision C0

Class A EMC Statements

FCC Part 15

NOTE  This equipment has been tested and found to comply with the limits for a Class A digital device, pursuant to part 15 of the FCC Rules. These limits are designed to provide reasonable protection against harmful interference when the equipment is operated in a commercial environment. This equipment generates, uses, and can radiate radio frequency energy and, if not installed and used in accordance with the instruction manual, may cause harmful interference to radio communications. Operation of this equipment in a residential area is likely to cause harmful interference in which case the user will be required to correct the interference at his own expense.

ICES-003

This Class A Interference Causing Equipment meets all requirements of the Canadian Interference Causing Equipment Regulations ICES-003.

Cet appareil numérique de la classe A respecte toutes les exigences du Règlement sur le matériel brouilleur du Canada.

IEC 62040-2

Some configurations are classified under IEC 62040-2 as "C2 UPS for Unrestricted Sales Distribution."

VCCI Notice

この装置は、情報処理装置等電波障害自主規制協議会（VCCI）の基準に基づくクラスA情報技術装置です。この装置を家庭環境で使用すると電波妨害を引き起こすことがあります。この場合には使用者が適切な対策を講ずるよう要求されることがあります。

Eaton reserves the right to change specifications without prior notice. Modbus is a registered trademark of Schneider Automation, Inc. MOXA is a registered trademark and MGate is a trademark of MOXA, Inc. Spiralock is a registered trademark of Spiralock Corporation. KIRK is a registered trademark of Kirk Key Interlock company, LLC, a subsidiary of Halma plc. National Electrical Code and NEC are registered trademarks of National Fire Protection Association, Inc. ERIFLEX and FLEXIBAR are registered trademark of Erico International Corporation. All other trademarks are property of their respective companies.

©Copyright 2006-2019 Eaton, Raleigh, NC, USA. All rights reserved. No part of this document may be reproduced in any way without the express written approval of Eaton.

Special Symbols

The following are examples of symbols used on the UPS or accessories to alert you to important information:



RISK OF ELECTRIC SHOCK - Observe the warning associated with the risk of electric shock symbol.



CAUTION: REFER TO OPERATOR'S MANUAL - Refer to your operator's manual for additional information, such as important operating and maintenance instructions.



This symbol indicates that you should not discard the UPS or the UPS batteries in the trash. This product contains sealed, lead-acid batteries and must be disposed of properly. For more information, contact your local recycling/reuse or hazardous waste center.



This symbol indicates that you should not discard waste electrical or electronic equipment (WEEE) in the trash. For proper disposal, contact your local recycling/reuse or hazardous waste center.



IMPORTANT

To ensure you have the most up-to-date content and information for this product, please review the latest manual revision on our website, www.eaton.com/9155.

Table of Contents

1 Introduction	1
1.1 Safety Warnings	1
1.2 Consignes de Sécurité	1
1.3 Advertencias de Seguridad	2
2 UPS-Mounted Bypass Switch Installation	3
2.1 MBM/PDM Setup	3
2.2 Wiring the MBM/PDM	5
3 Maintenance Bypass Switch Operation	11
3.1 Maintenance Bypass Startup	12
3.2 Transfer the Load from the UPS to Maintenance Bypass	13
3.3 Transfer the Load from Maintenance Bypass to the UPS	13
4 Warranty	15

Table of Contents

Chapter 1 Introduction

The Maintenance Bypass Module (MBM) and Power Distribution Module (PDM) are designed to work with an 8–15 kVA Eaton® 9155 uninterruptible power system (UPS). Both modules provide a Make-Before-Break (MBB) wrap-around bypass for UPS maintenance or service without shutting down the load. The PDM also comes equipped with several different types of output receptacles.

1.1 Safety Warnings

IMPORTANT SAFETY INSTRUCTIONS SAVE THESE INSTRUCTIONS

This manual contains important instructions that you should follow during installation and maintenance of the UPS and batteries. Please read all instructions before operating the equipment and save this manual for future reference.

 **DANGER**

This UPS contains LETHAL VOLTAGES. All repairs and service should be performed by AUTHORIZED

 **WARNING**

- This UPS contains its own energy source (batteries). The UPS output may carry live voltage even when the UPS is not connected to an AC supply.
- To reduce the risk of fire or electric shock, install this UPS in a temperature and humidity controlled, indoor environment, free of conductive contaminants. Ambient temperature must not exceed 40°C (104°F). Do not operate near water or excessive humidity (95% maximum).
- To reduce the risk of fire, connect only to a circuit provided with 100 amperes maximum branch circuit overcurrent protection in accordance with the National Electrical Code, ANSI/NFPA 70.
- Output overcurrent protection and disconnect switch must be provided by others.

1.2 Consignes de Sécurité

CONSIGNES DE SÉCURITÉ IMPORTANTES – CONSERVER CES INSTRUCTIONS

Ce manuel comporte des instructions importantes que vous êtes invité à suivre lors de toute procédure d'installation et de maintenance des batteries et de l'onduleur. Veuillez consulter entièrement ces instructions avant de faire fonctionner l'équipement et conserver ce manuel afin de pouvoir vous y reporter ultérieurement.

 **DANGER!**

Cet onduleur contient des TENSIONS MORTELLES. Toute opération d'entretien et de réparation doit être EXCLUSIVEMENT CONFIEE A UN PERSONNEL QUALIFIE AGRÉÉ. AUCUNE PIÈCE RÉPARABLE PAR L'UTILISATEUR ne se trouve dans l'onduleur.



AVERTISSEMENT!

- Cette onduleur possède sa propre source d'alimentation (batteries). Il est possible que la sortie de l'onduleur soit sous tension même lorsque l'onduleur n'est pas connectée à une alimentation CA.
 - Pour réduire les risques d'incendie et de décharge électrique, installer l'onduleur uniquement à l'intérieur, dans un lieu dépourvu de matériaux conducteurs, où la température et l'humidité ambiantes sont contrôlées. La température ambiante ne doit pas dépasser 40 °C. Ne pas utiliser à proximité d'eau ou dans une atmosphère excessivement humide (95 % maximum).
 - Afin de réduire les risques d'incendie, n'effectuez le raccordement qu'avec un circuit muni d'une protection de surintensité du circuit de dérivation maximum de 100 ampères conformément au Code Électrique National (National Electrical Code) des États-Unis ANSI/NFPA 70.
 - La protection de surintensité de sortie ainsi que le sectionneur doivent être fournis par des tiers.
-

1.3 Advertencias de Seguridad

INSTRUCCIONES DE SEGURIDAD IMPORTANTES – GUARDE ESTAS INSTRUCCIONES

Este manual contiene instrucciones importantes que debe seguir durante la instalación y el mantenimiento del SIE y de las baterías. Por favor, lea todas las instrucciones antes de poner en funcionamiento el equipo y guarde este manual para referencia en el futuro.



PELIGRO

Este SIE contiene VOLTAJES MORTALES. Todas las reparaciones y el servicio técnico deben ser efectuados SOLAMENTE POR PERSONAL DE SERVICIO TÉCNICO AUTORIZADO. No hay NINGUNA PARTE QUE EL USUARIO PUEDA REPARAR dentro del SIE.



ADVERTENCIA

- Este SIE contiene su propia fuente de energía (baterías). La salida del SIE puede transportar voltaje activo aun cuando el SIE no esté conectado con una fuente de CA.
 - Para reducir el riesgo de incendio o de choque eléctrico, instale este SIE en un lugar cubierto, con temperatura y humedad controladas, libre de contaminantes conductores. La temperatura ambiente no debe exceder los 40°C. No trabaje cerca del agua o con humedad excesiva (95% máximo).
 - Para reducir el riesgo de incendio, realice la conexión únicamente hacia un circuito que cuente con un máximo de 100 amperios de protección contra sobrecorriente de circuito derivado, de acuerdo con el Código Eléctrico Nacional, ANSI/NFPA 70.
 - La protección contra sobrecorriente de salida y el conmutador de desconexión debe suministrarse por parte de terceros.
-

Chapter 2 UPS-Mounted Bypass Switch Installation

This chapter describes the Maintenance Bypass Module (MBM) and Power Distribution Module (PDM) installation. Both modules have a Make-Before-Break (MBB) maintenance bypass switch.



NOTE

If you are installing an optional isolation transformer with the MBM, refer to the Eaton 9155 UPS (8–15 kVA) User's Guide for installation instructions.

2.1 MBM/PDM Setup

If you purchased an optional MBM/PDM, attach the module to the UPS before any wiring installation. All hardware is supplied in the accessory kit.

To attach the optional MBM/PDM to the UPS:

1. Remove the connecting plate between the top cabinet and the cabinet below it on the UPS rear panel (see [Figure 1](#)). Discard the plate. Retain the screws for later use.
2. Remove the lowest top cover screw on each side of the UPS and discard.

Figure 1. UPS Rear View (2-High Cabinet Shown)

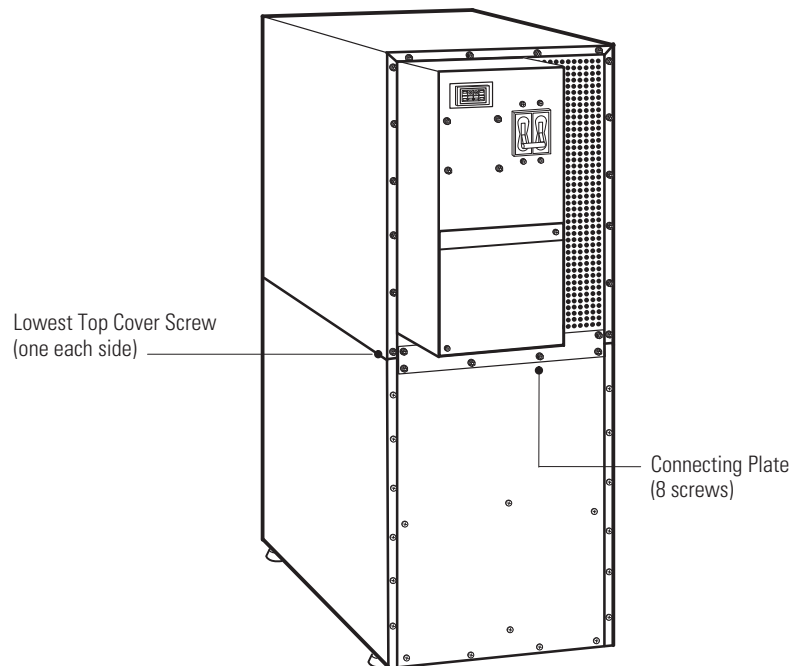

3. Attach the supplied L-bracket to the lower rear (for 2-high) or middle rear (for 3-high) cabinet using three screws (see [Figure 2](#)).
Repeat for the other side.
4. Remove the UPS wiring access cover and retain.

Figure 2. Attaching the L-Brackets

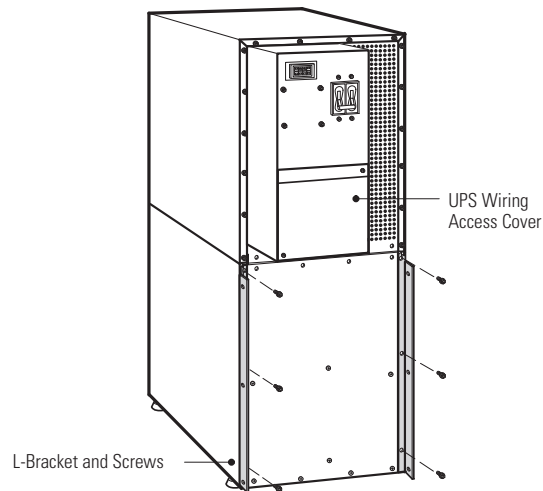

5. Remove the MBM/PDM wiring access cover and one of the conduit landing plates and retain (see [Figure 3](#)).
6. Tilt the top of the module forward and slide the module onto the L-brackets. The top left flange on the module fits up under the UPS electronics unit through an access slot.

Figure 3. Installing the MBM or PDM (MBM Shown)

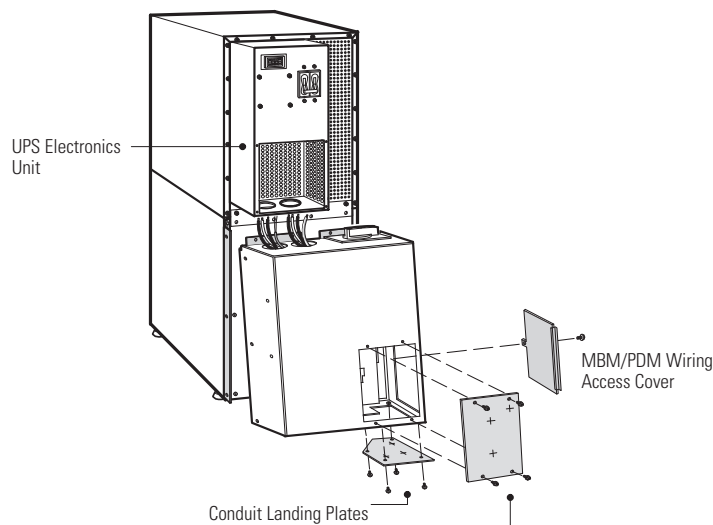

7. Secure the sides of the module to the L-brackets using six screws (see [Figure 4](#)).

8. Secure the top of the module to the top cabinet using four of the screws removed in Step 1.
9. Continue to the following section, [Figure 4](#).

Figure 4. Securing the MBM or PDM (MBM Shown)

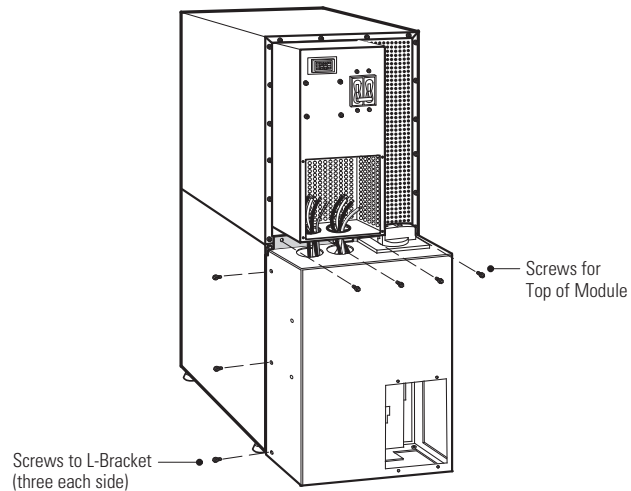

2.2 Wiring the MBM/PDM

The Eaton 9155 UPS has the following power connections:

- 2-phase (L1 and L2), neutral, and ground connection for rectifier/bypass input
- 2-phase (L1 and L2), neutral, and ground connection for load output

The nominal input/output voltages are:

- 100/200, 110/220, or 120/240 Vac with 180° phase displacement
- 120/208 or 127/220 Vac with 120° phase displacement

Output overcurrent protection and disconnect switch must be provided by others.

[Figure 8](#) and [Figure 9](#) show the oneline diagrams of the MBM and PDM with the UPS.

WARNING

Only qualified service personnel (such as a licensed electrician) should perform the UPS installation and initial startup. Risk of electrical shock.

To hardwire the MBM/PDM:

1. Verify that the electrical connections to the installation site have been properly installed.
2. A wall-mounted, user-supplied, readily-accessible disconnection device must be incorporated in the input wiring.

Compare the circuit breaker ratings and wire sizes to the specifications in [Table 1](#).

i NOTE To accommodate the feature of easy system expandability, it is recommended that initial installation of the Eaton 9155 UPS contain wiring to support the maximum capacity of the UPS cabinet.

3. Switch off utility power to the distribution point where the UPS will be connected. Be absolutely sure there is no power.
4. Determine your equipment's grounding requirements according to your local electrical code.
5. Verify that the UPS battery circuit breaker is in the OFF position (see [Figure 5](#)).

Figure 5. UPS with MBM Rear View

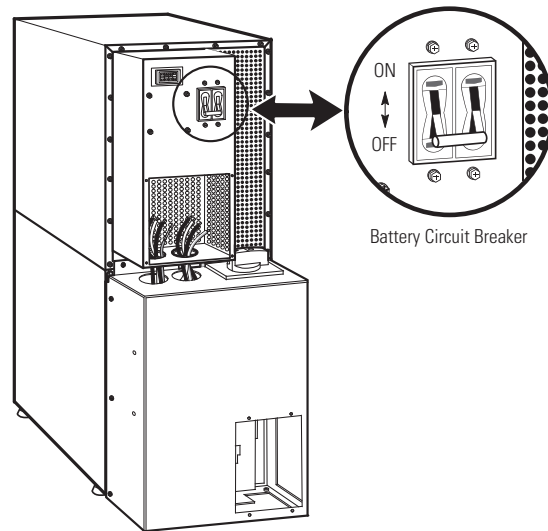

6. Punch two holes in the MBM/PDM conduit landing plate for the input and output conduit using a Greenlee® punch or similar device.
7. Hardwire the input, output, and ground terminations for the MBM/PDM.
See [Table 1](#) for specifications and [Figure 6](#) for a detailed view of the MBM/PDM terminal block.

Figure 6. MBM/PDM Hardwiring (PDM Shown)

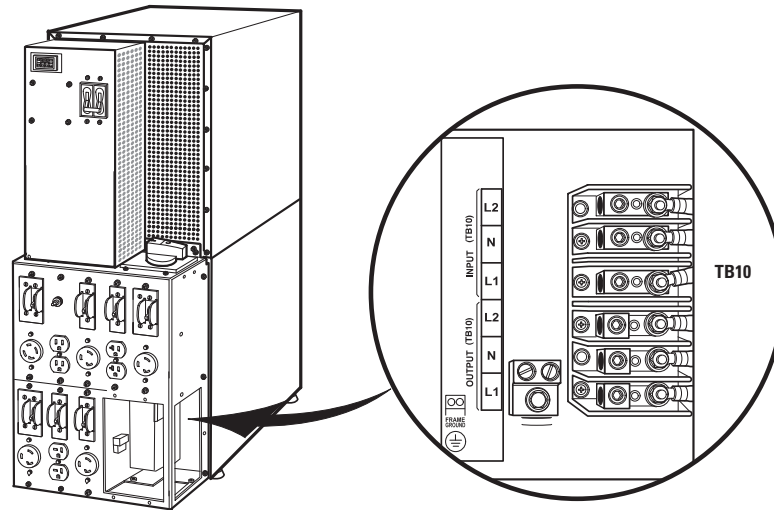

! IMPORTANT

Input neutral must be wired for proper operation. Failure to connect an input neutral will void the warranty. However, when wired with the optional isolation transformer, input neutral is supplied by the isolation transformer.

Table 1. MBM/PDM Terminal Block (TB10) Wiring

Wire Functions		Input Circuit Breaker Rating		Minimum Wire Size*	Tightening Torque	Conduit Connection (Entry Size)
Input	Ground			8 AWG		
	L1	8 kVA	60A	4 AWG (21.2 mm ²)	120 lb in (13.5 Nm)	2" access hole for 1-1/2" conduit
	Neutral	10 kVA	80A	3 AWG (26.7 mm ²)		
	L2	12kVA	100A	2 AWG (33.6 mm ²)		
		15 kVA	100A	2 AWG (33.6 mm ²)		
Output	L1			3 AWG	120 lb in (13.5 Nm)	2" access hole for 1-1/2" conduit
	Neutral			3 AWG		
	L2			3 AWG		
	Ground			8 AWG		

* Use only 75°C-rated copper wire. Minimum wire size is based on 120/208 full load ratings applied to NEC Code Table 310-16. Code may require a larger AWG size than shown in this table because of temperature, number of conductors in the conduit, or long service runs. Follow local requirements.

- Connect the factory-installed wiring from the maintenance bypass switch to the UPS terminal block (see [Figure 7](#)).

9. Connect the maintenance bypass (red and black) wires to TB1-2 (the A/B maintenance bypass auxiliary contacts) on the UPS terminal block.

Figure 7. Wiring from Maintenance Bypass Switch to UPS

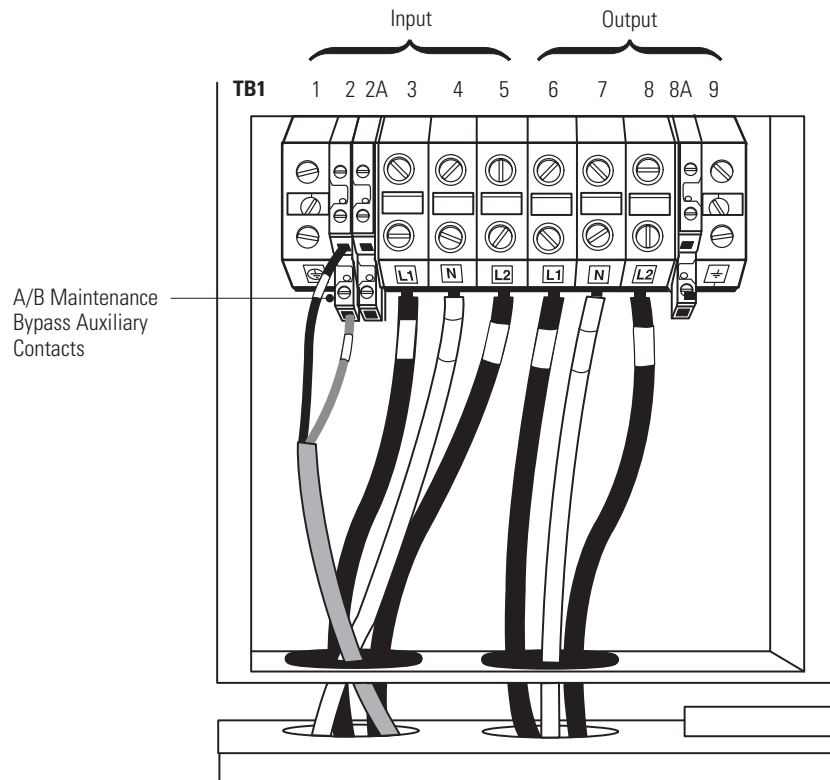

10. Replace the wiring access cover on the UPS.
11. Replace the MBM/PDM wiring access cover and conduit landing plate.
12. Continue to "Stabilizing the Cabinet" in the Eaton 9155 UPS (8–15 kVA) User's Guide to complete the installation.

Figure 8. UPS with MBM Wiring Diagram

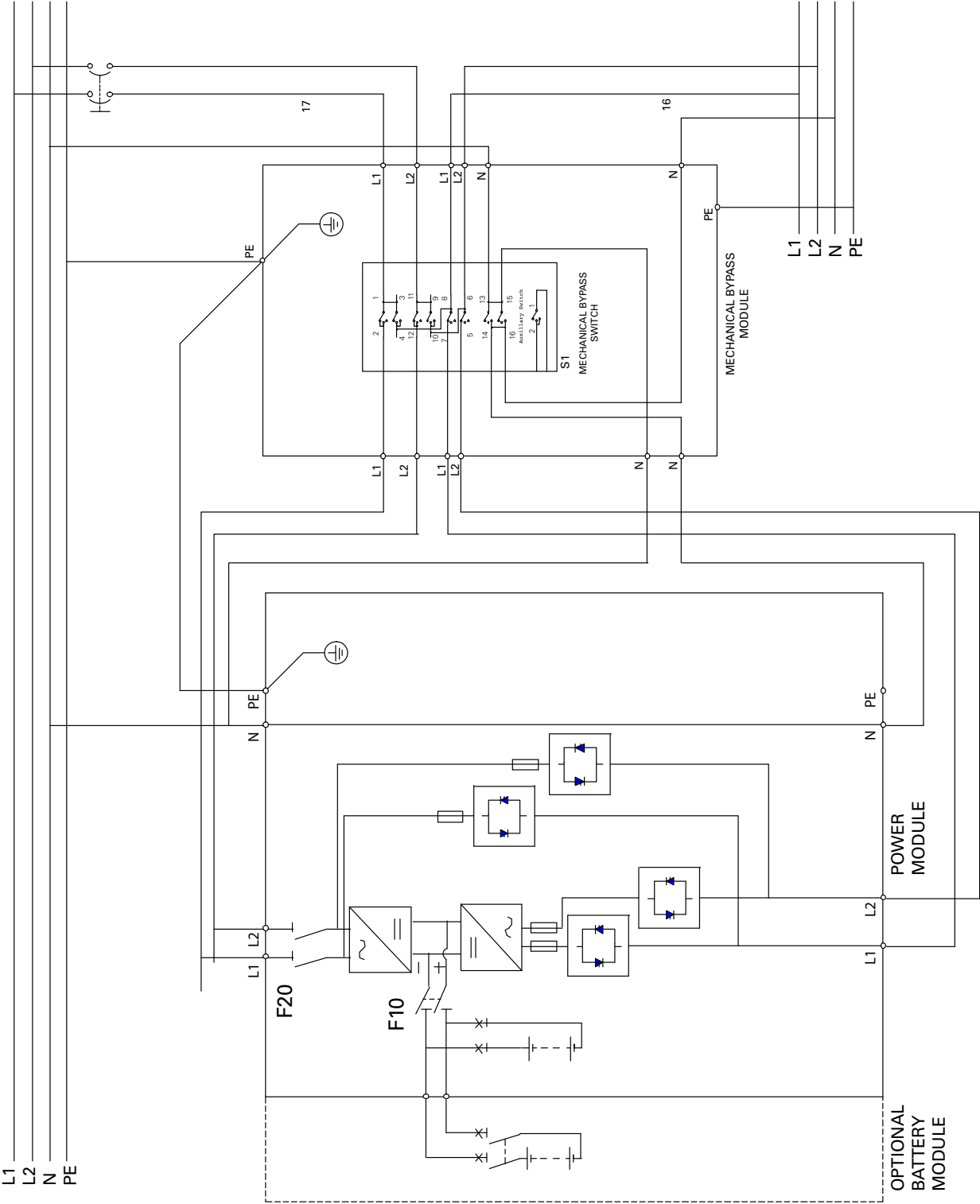
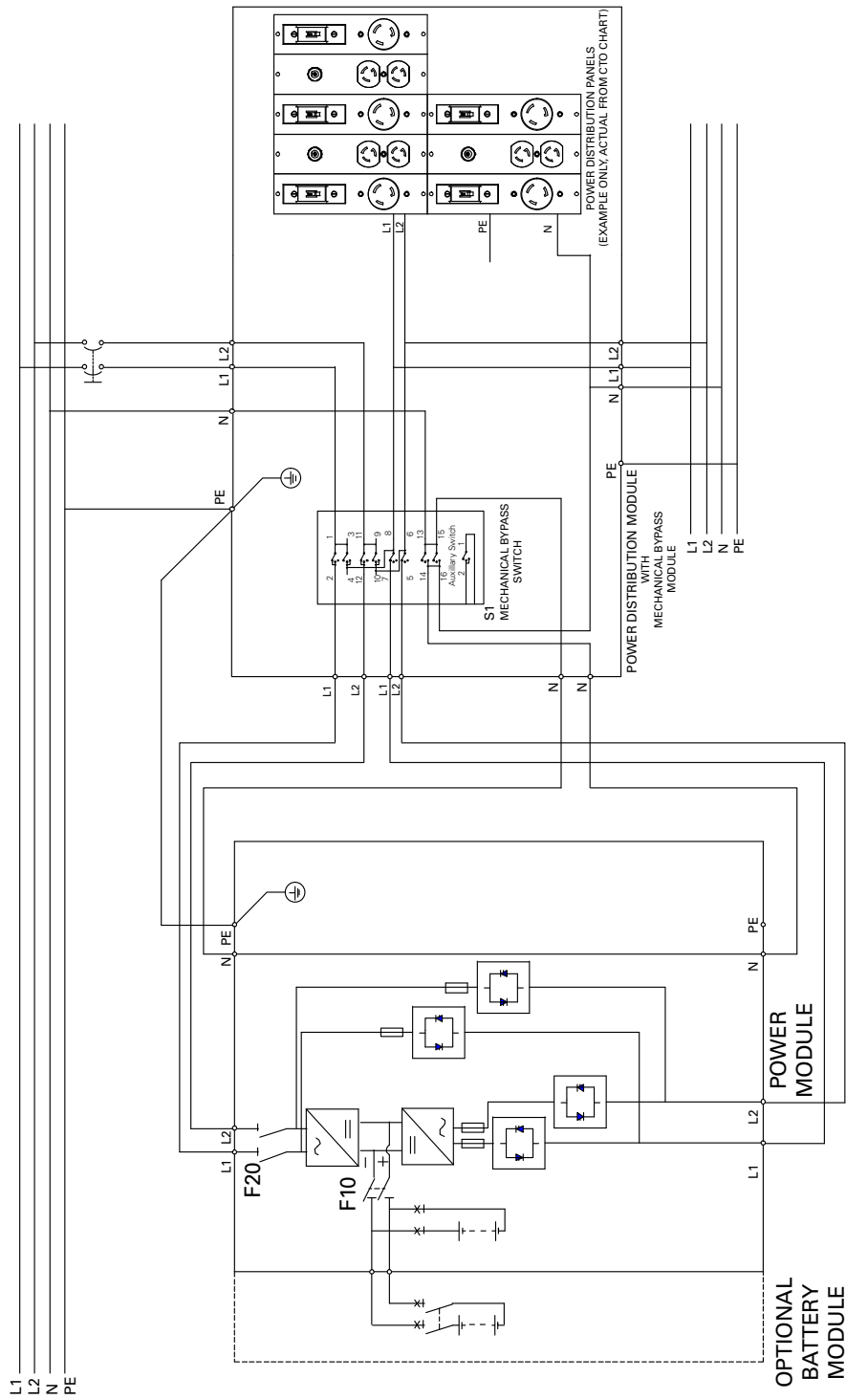

Figure 9. UPS with PDM Wiring Diagram



Chapter 3 Maintenance Bypass Switch Operation

This chapter describes:

- Startup in Maintenance Bypass mode
- Transferring the load to maintenance bypass
- Returning the load to Normal mode

The UPS-mounted maintenance bypass switch is part of the Maintenance Bypass Module (MBM) or Power Distribution Module (PDM) and is located on the back of the UPS (see [Figure 10](#)).

Figure 10. Maintenance Bypass Switch (PDM Shown)

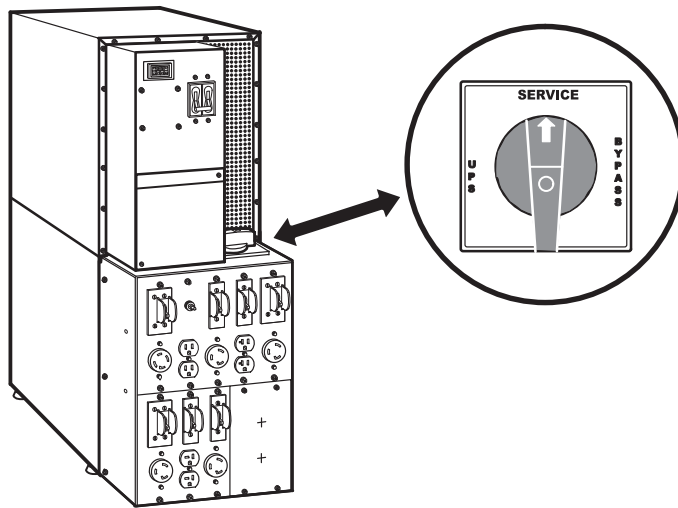

NOTE

In the UPS or SERVICE position, AC input power is still connected to the input terminals inside the UPS.

Table 2. UPS-Mounted Bypass Switch Positions

Switch Position	Description
UPS	Connects the UPS output to the load.
SERVICE	Connects the load directly to AC input power and disconnects UPS output. AC input power is still connected to the UPS input.
BYPASS	Like the SERVICE position, BYPASS connects the load directly to AC input power and disconnects UPS output. However, because BYPASS also disconnects AC input from the UPS, this is the appropriate position for UPS maintenance or repair.

[Figure 11](#) shows a UPS with a separate battery cabinet and a UPS-mounted bypass switch.

Figure 11. Typical Hardwired Installation with UPS-Mounted Bypass Switch

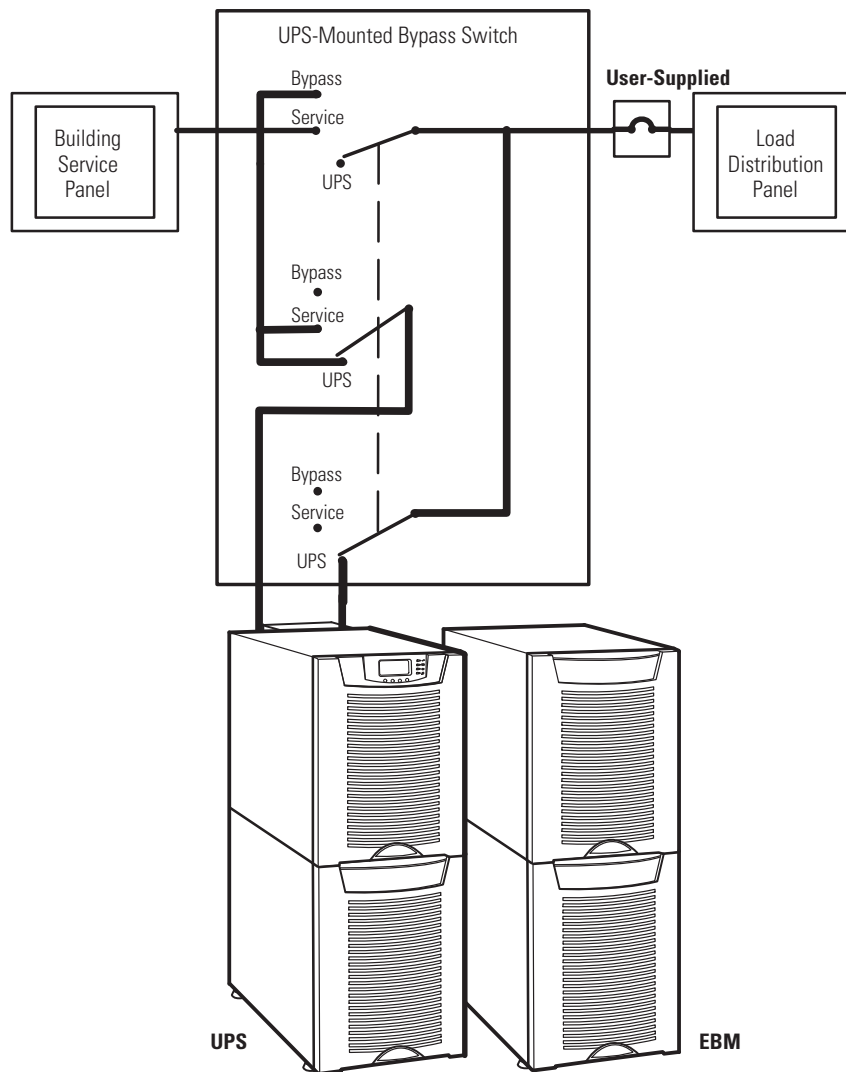

3.1 Maintenance Bypass Startup

To start the UPS in maintenance bypass:



1. Verify that the maintenance bypass switch is in the BYPASS position (see [Figure 10](#)).
2. Switch ON the utility power where the UPS is connected.
The load is now powered by utility power.
3. To transfer the load to the UPS, see paragraph [3.3 Transfer the Load from Maintenance Bypass to the UPS](#).

3.2 Transfer the Load from the UPS to Maintenance Bypass

1. Remove the cables and screws for any ConnectUPS Web/SNMP or PXGX card and then remove the x-slot card.

NOTE

Before proceeding ensure that there are no active alarms or notices.

2. Set the system to internal Bypass mode:
 - Using the  button on the front panel display, scroll to the **Control** menu option and press the  button.
 - Press the  button to select the **Go to Bypass Mode** option.



The  indicator illuminates indicating the UPS system is operating in Bypass mode.
3. Turn the maintenance bypass switch on the back of the UPS to the SERVICE position (see [Figure 10](#)).

The Normal LED  will be flashing.

The UPS is now bypassed, with the load powered by utility power.

Verify the load has been transferred to bypass by viewing the output meters screen.

4. Command the UPS off.

Press the  button on the front display, scroll to the UPS On/Off menu. Press the  button to turn the UPS off.

Rear fan is running signifying load is being supplied utility power on bypass.
5. Switch all of the UPS battery circuit breakers to the Off position.
6. Turn the maintenance bypass switch on the back of the UPS to the Bypass position (see [Figure 10](#)).

3.3 Transfer the Load from Maintenance Bypass to the UPS

1. Turn the maintenance bypass switch on the back of the UPS to the SERVICE position (see [Figure 10](#)).
2. Switch all of the UPS battery circuit breakers to the ON position.
3. Wait 1.5 to 2 minutes for the internal startup process to complete.

Wait until the bypass indicator illuminates and the two front fans are operating before proceeding to the next step.

Verify the output voltage is present on the meters screen.
4. Turn the maintenance bypass switch on the back of the UPS to the UPS position to return to Normal mode (see [Figure 10](#)).

When the green UPS normal indicator illuminates, the UPS is powering the load.

Verify the load is transferred to the UPS by viewing the output meters screen.
5. Reinstall any ConnectUPS Web/SNMP or PXGX cards, secure with retained hardware and connect cables.

Maintenance Bypass Switch Operation

Chapter 4 Warranty

For warranty information, please refer to the Resources link on our website, www.eaton.com/9155.

EQUIPMENT REGISTRATION

Please visit www.eaton.com/pg/register to register your new Eaton UPS / Eaton UPS Accessory.

Model Number:

Serial Number:



164201644 C0