

WEIGHT AND CENTER OF GRAVITY				
	A	B	C	WEIGHT
	MM [INCH]	MM [INCH]	MM [INCH]	KG [LBS]
9155 8-15 kVA UPS 2 HIGH	81 [3.2]	452 [17.8]	406 [16.0]	169 [373]

- NOTES:
1. THE SYSTEM MUST BE INSTALLED ON A LEVEL FLOOR SURFACE SUITABLE FOR COMPUTER OR ELECTRONIC EQUIPMENT.
 2. CONTROL WIRING ENTRY THROUGH REMOVABLE CONDUIT LANDING PLATE.
 3. THE SYSTEM MUST BE INSTALLED IN A TEMPERATURE AND HUMIDITY CONTROLLED INDOOR AREA FREE OF CONDUCTIVE CONTAMINANTS.
 4. AMBIENT TEMPERATURE RANGE 5-40°C [41-104degF] AT AN OPERATING ELEVATION UP TO 3000M WITHOUT DERATING.
STORAGE TEMPERATURE -25 to +55°C.
RELATIVE HUMIDITY (OPERATING AND STORAGE) 5% TO 95% MAX NON CONDENSING.
 5. UPS CABINET CLEARANCES:
FRONT OF THE CABINET: 914MM [36.0"]
RIGHT OF THE CABINET: 914MM [36.0"]
LEFT OF THE CABINET: NONE
VENTILATION REAR: 152MM [6.0"]
 6. MINIMUM REQUIRED AIR FLOW FOR CABINET AT FULL LOAD IS 800 CFM.
 7. ALL WIRING IN ACCORDANCE WITH NATIONAL AND LOCAL ELECTRIC CODES.
 8. WEIGHT OF THE CABINET DOES NOT INCLUDE CUSTOMER WIRING.
 9. AC INPUT TO UPS RECTIFIER / BYPASS: 1 PHASE, NEUTRAL, GROUND.
DC INPUT TO UPS (EXTERNAL BATTERY ONLY): POSITIVE, NEGATIVE, GROUND.
 10. THE NOMINAL INPUT/OUTPUT VOLTAGES ARE:
120/208 OR 127/220 VAC (UPS ONLY OR PARALLEL SYSTEM)
 11. SPECIFICATIONS ARE SUBJECT TO CHANGE.

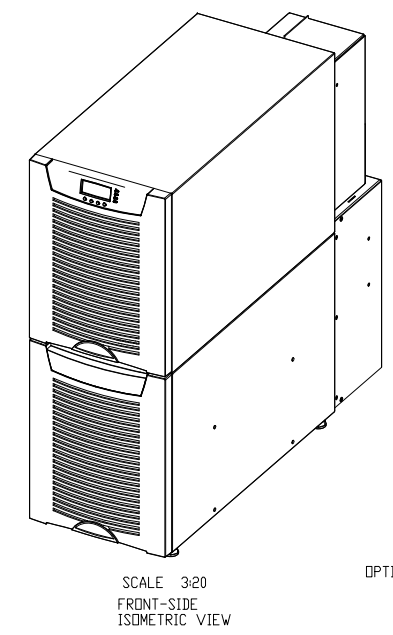

SCALE 3:20
FRONT-SIDE
ISOMETRIC VIEW

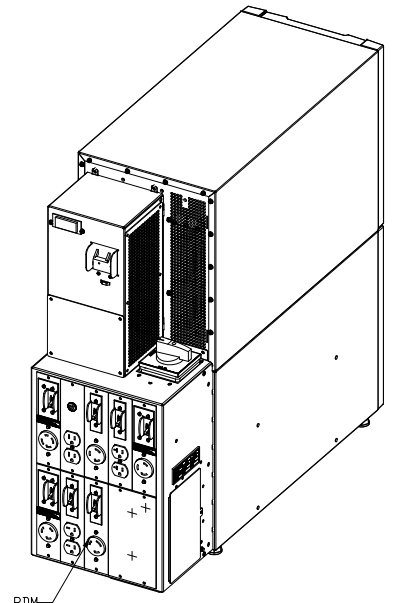

SCALE 3:20
BACK-SIDE
ISOMETRIC VIEW

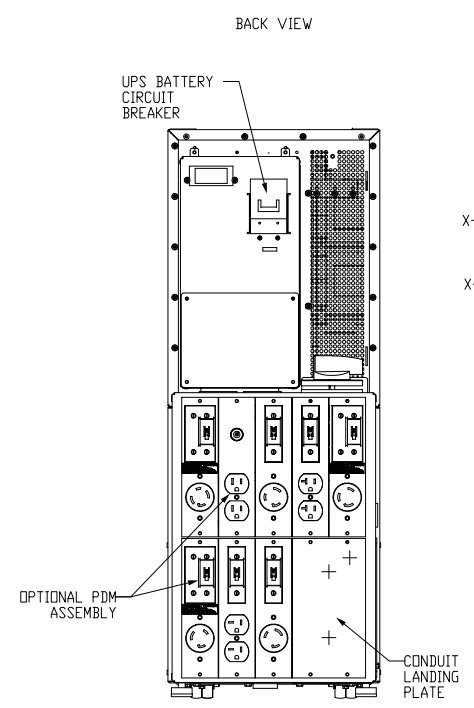
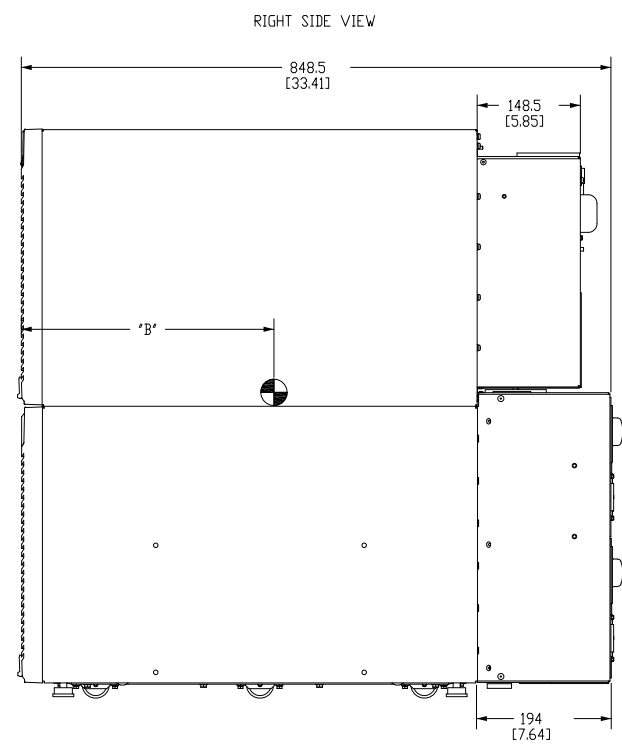
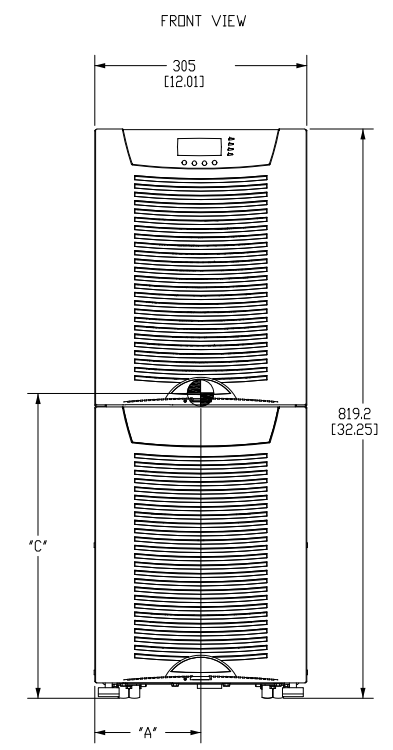

FRONT VIEW, NO FRONT PANELS

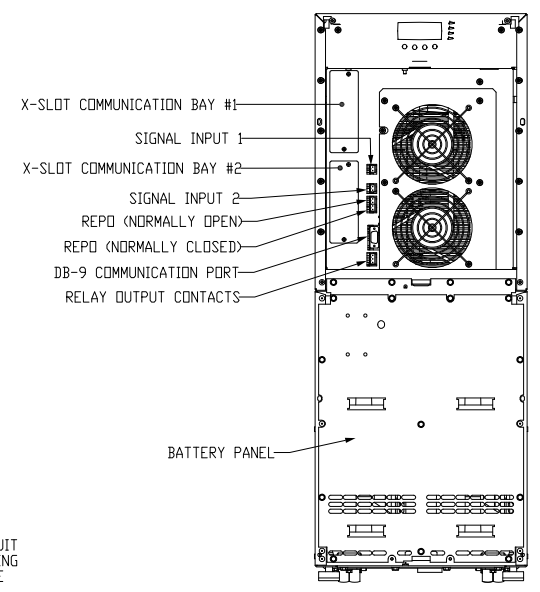

FRONT VIEW, NO FRONT PANELS
NO BATTERY PANEL

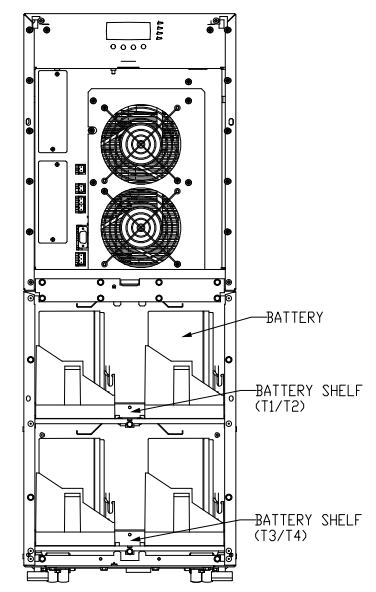

METRIC		EATON CORPORATION		EATON	
DIMENSIONS ARE IN MILLIMETERS AFTER PLATING. DIMENSIONS AND TOLERANCES IN ACCORDANCE WITH ASME Y14.5M-1994. SEE NOTES FOR TOLERANCES.					
DESCRIPTION: 9155 8-15 kVA UPS 2 HIGH SITE PLAN					
DESIGNER: A. PANWAR	26-BCC-2010	ECD: ECD-155767	NAME:	REVISION: 01	SIZE: A1
CHECKED:				STATE: RELEASE	SCALE:
SAFETY:					1:5
APPROVED:					SHEET:
					1 OF 2

NOTE: DIAGRAM ILLUSTRATES ONE OUT OF TWO BATTERY STRINGS (2 HIGH CONFIGURATION). BATTERY SYMBOL SHOWN REPRESENTS A BATTERY TRAY ASSEMBLY CONTAINING 8 BATTERIES.

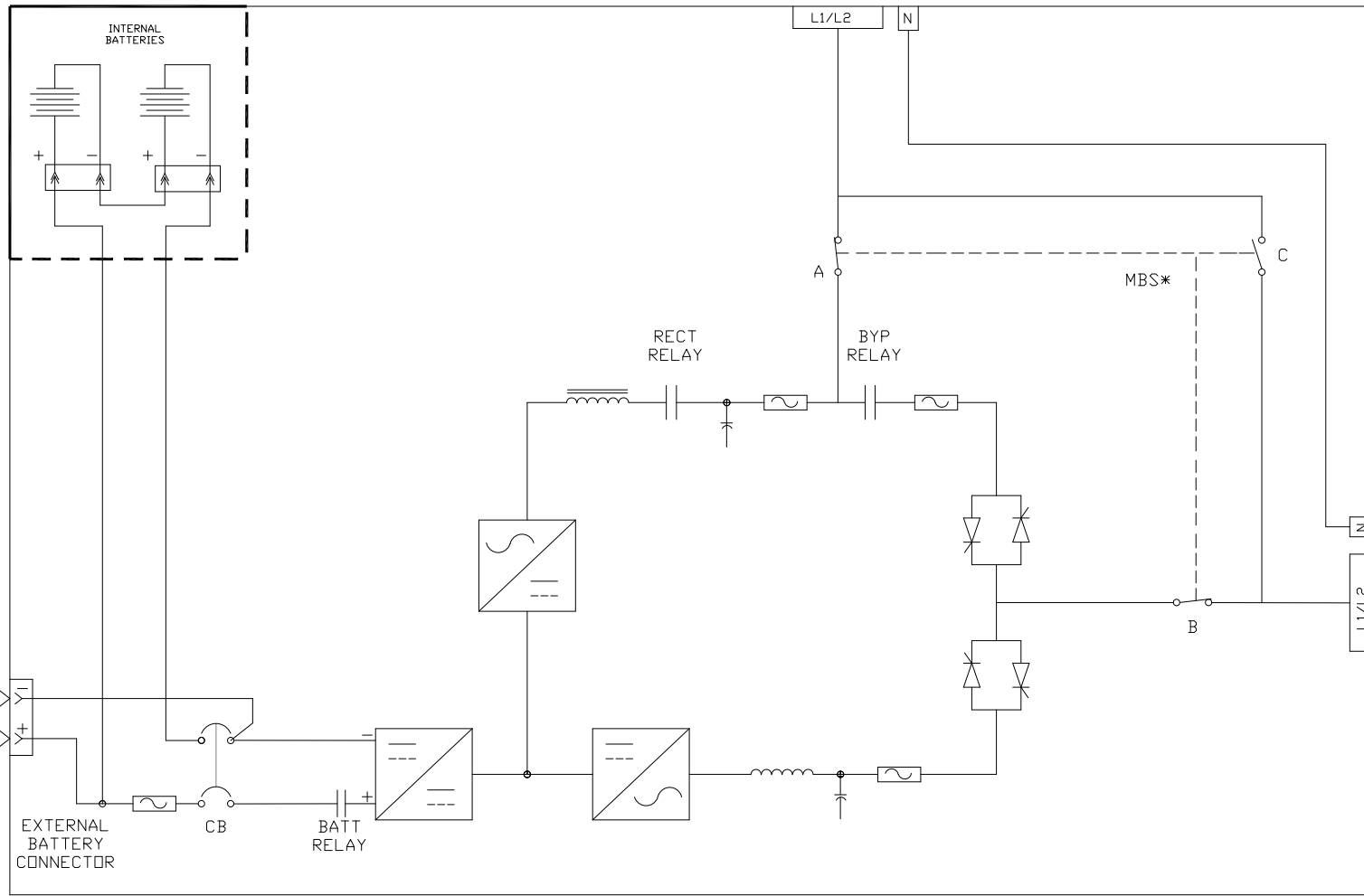

ONE LINE DIAGRAM FOR 9155 8-15KVA 2 HIGH UPS WITH INTERNAL BATTERIES

NOTES:

- USE ONLY 90°C-RATED COPPER WIRE. MINIMUM WIRE SIZE IS BASED ON 120/208 FULL LOAD RATINGS APPLIED TO NATIONAL ELECTRICAL CODE (NEC) TABLE 310.15(B)(16). CODE MAY REQUIRE A LARGER AWG SIZE THAN SHOWN IN THIS TABLE BECAUSE OF TEMPERATURE, NUMBER OF CONDUCTORS IN THE CONDUIT, OR LONG SERVICE RUNS. FOLLOW LOCAL REQUIREMENTS.
- PER NEC ARTICLE 300-20(A) FOR FERROUS METAL RACEWAYS, ALL THREE-PHASE CONDUCTORS MUST BE RUN IN THE SAME CONDUIT. NEUTRAL AND GROUND MUST BE RUN IN THE SAME CONDUIT AS THE PHASE CONDUCTORS.
- CONDUIT IS SIZED TO ACCOMMODATE ONE NEUTRAL CONDUCTOR THE SAME SIZE AS THE PHASE CONDUCTOR AND ONE GROUND CONDUCTOR. IF TWO NEUTRAL CONDUCTORS OR AN OVERSIZED NEUTRAL CONDUCTOR ARE TO BE INSTALLED, CHECK THE SIZE OF THE CONDUIT NEEDED TO ACCOMMODATE THE EXTRA WIRE OR SIZE AND USE THAT CONDUIT SIZE IN PLACE OF THE CONDUIT SIZE LISTED. CONDUIT SIZES WERE CHOSEN FROM NEC TABLE C1, TYPE LETTERS RHH, RHW, RHW-2, TW, THW, THW-2.

BREAKER AND FUSE INFORMATION		
BREAKER / FUSE APPLICATION	MANUFACTURER	PART NUMBER
BATTERY BREAKER	AIRPAX	229-2-1REC5-33735-100
INPUT FUSE	COOPER BUSSMANN	80 LET
OUTPUT FUSE	COOPER BUSSMANN	80 LET
BYPASS FUSE	COOPER BUSSMANN	125 LET

9155 8-15 kVA UPS 2 HIGH SITE PLAN	PACKAGED ENVELOPE DIMENSIONS MM [INCHES]		
	WIDTH	DEPTH	HEIGHT
	812 [32]	1118 [44.0]	975 [38.4]

MBS	UPS	SERVICE	BYPASS
A	CLOSED	CLOSED	OPEN
B	CLOSED	OPEN	OPEN
C	OPEN	CLOSED	CLOSED

*MBS OPTIONAL FOR 9155; NORMALLY A & B ARE HARDWIRED AND THE C PATH DOES NOT EXIST.

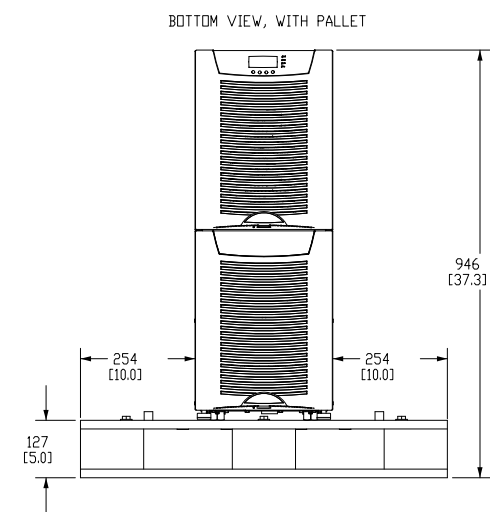
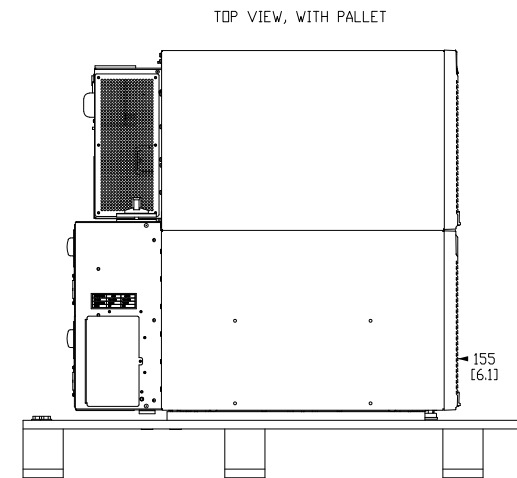
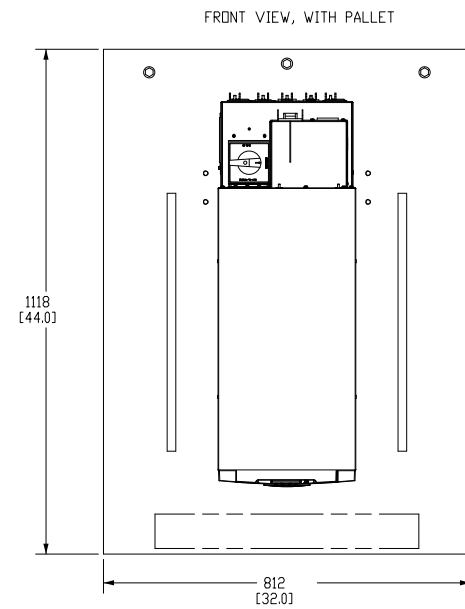

METRIC		EATON CORPORATION		EATON	
DESCRIPTION: 9155 8-15 kVA UPS 2 HIGH SITE PLAN					
DESIGNED BY: A. PANWAR	DATE: 26-DEC-2010	ECD: ECD-155767	NAME:	REVISION: 01	SIZE: A1
CHECKED:	DOCUMENT TYPE:	P-110000689		STATE:	SCALE:
SAFETY:	PROJ-E DRAWING			RELEASE:	13000
APPROVED:					SHEET: 2 OF 2

THIS DOCUMENT, INCLUDING THE DRAWING AND INFORMATION CONTAINED THEREIN, IS THE EXCLUSIVE PROPERTY OF EATON CORPORATION AND IS NOT TO BE REPRODUCED OR TRANSMITTED IN ANY FORM OR BY ANY MEANS, ELECTRONIC OR MECHANICAL, INCLUDING PHOTOCOPYING, RECORDING, OR BY ANY INFORMATION STORAGE AND RETRIEVAL SYSTEM, WITHOUT THE WRITTEN PERMISSION OF EATON CORPORATION. IN THE EVENT OF CONFLICTING CONSTRUCTION, THE DRAWING SHALL GOVERN THE STATUS OF THIS DOCUMENT.