

**User's Guide  
UPS 20 - 40 kVA,  
230/400 V 50/60 Hz output  
(3-phase input/output)**

**©2006 Eaton Corporation**

**All Rights Reserved**

The contents of this manual are the copyright of the publisher and may not be reproduced (even extracts) unless permission granted. Every care has been taken to ensure the accuracy of the information contained in this manual, but no liability can be accepted for any errors or omission. The right to make design modifications is reserved.

# User's Guide UPS 20 - 40 kVA, 230/400 V 50/60 Hz output (3-phase input/output)

1025358 revision D

<b>1. Safety instructions</b>	<b>5</b>
Audience	5
CE marking	5
User precautions	6
Environment	6
Inquiries	6
<b>2. Introduction</b>	<b>7</b>
System description	7
Feature: Active-Front Technology	7
Feature: Advanced Battery Management (ABM) <sup>™</sup>	8
Feature: Hot Sync <sup>®</sup> technology	8
Basic system configuration	9
<b>3. Mechanical installation</b>	<b>10</b>
Delivery check	10
Unpacking and visual inspection	10
<b>4. Planning before installation</b>	<b>12</b>
<b>5. Cabinet installation</b>	<b>13</b>
Maintenance bypass switch	15
External battery cabinet option	15
Battery racks	15
<b>6. Electrical installation</b>	<b>16</b>
Power cables and protective fuses	17
Wiring procedure	18
The installation procedure:	18
External Battery Cabinet (EBC) installation procedure	21
<b>7. Software and connectivity</b>	<b>22</b>
Communication cables	22
Connection to the standard RS-232 port (X53)	23
LanSafe software	23
External control connections	24
Emergency Power Off (EPO)	24
Relay outputs	25
Programmable signal inputs	25
XSlot communication	26
Web/SNMP Module (optional)	27
AS/400 Relay Module (optional)	27
Single Serial Port Module (optional)	28
Modbus/Jbus Module (optional)	28

<b>8. User operations.....</b>	<b>29</b>
Display functions.....	29
User Settings .....	30
Changing language.....	32
Using relay outputs.....	32
Normal start-up .....	32
Battery start-up .....	33
Start-up after EPO.....	33
Shutdown .....	33
<b>9. Maintenance .....</b>	<b>34</b>
Regular service/intervals.....	34
Batteries.....	35
Cooling fan.....	35
LED Indicators .....	35
Maintenance bypass switch (MBS) operation .....	36
Turn UPS from normal mode to maintenance bypass mode (service bypass mode) .....	36
Turn UPS from maintenance bypass to normal mode.....	37
<b>10. Parallel systems .....</b>	<b>39</b>
Overview.....	39
SPM cabinets .....	40
Notice! .....	40
Aux. MBS contacts.....	45
XSlot Hot Sync card: installing and wiring .....	46
Start-up and operation.....	48
Start-up procedure.....	48
Operating system bypass switch.....	49
SPM-30-2 and SPM-60-2 .....	49
SPM-30-4 and SPM-40-4 .....	49
Shut-down procedure.....	50
Local tie panel solutions.....	51
<b>11. Recycling the used UPS or batteries .....</b>	<b>51</b>
<b>12. Dimensional drawings .....</b>	<b>52</b>
<b>13. Technical data.....</b>	<b>53</b>
Standards .....	53
Environment.....	53
Maintenance configuration.....	53
Characteristics .....	53
AC input .....	54
DC circuit.....	54
AC output.....	54
<b>14. Warranty.....</b>	<b>55</b>

# 1. Safety instructions

The UPS operates with mains, battery or bypass power. It contains components that carry high currents and voltages. The properly installed enclosure is earthed and IP20 rated against electrical shock and foreign objects. However, only qualified personal is allowed to install and service the UPS.



## **Warning!**

**Operations inside the UPS must be performed by a service engineer from the manufacturer or from an agent authorised by the manufacturer.**

Do not ever service inside the UPS when mains power is applied or the UPS is in battery mode. Use the optional Maintenance Bypass Switch (MBS) if installed to the system. Remember to open battery breaker. Always ensure by measuring with a multi-meter that no dangerous voltages are present.

## **Audience**

The intended audiences of this manual are people who plan the installation, install, commission, and use or service the UPS. The manual provides guidelines to check delivery, installing and commissioning of the UPS.

The reader is expected to know the fundamentals of electricity, wiring, electrical components and electrical schematic symbols. This manual is written for a global reader.



## **Note!**

**Read the manual before operating or working on the UPS.**

## **CE marking**

The product has the CE marking in compliance with the following European directives:

- LV Directive (Safety)      73/23/EEC and 93/68/EEC
- EMC Directive              89/336/EEC, 93/68/EEC and 92/31/EEC

Declaration of conformity with UPS harmonised standards and directives EN 62040-1-1 (Safety) and EN 50091-2 (EMC) are available on the web site (<http://www.powerware.com>).

## User precautions

The only user operations permitted are:

- Start up and shut down of the UPS, excluding the commissioning start-up.
- Use of the LCD control panel and Maintenance Bypass Switch (MBS)
- Use of optional connectivity modules and their software

The user must follow the precautions and only perform the described operations. Any deviations from the instructions could be dangerous to the user or cause accidental load loss.



### **Warning!**

**The user is not permitted to open of any screws excluding connectivity plates and the MBS locking plate. Failure to recognise the electrical hazards could prove fatal.**

## Environment

The UPS must be installed according to the recommendations in this manual. Under no circumstances the UPS should be installed in an airtight room, in the presence of flammable gases, or in an environment exceeding the specification.

Excessive amount of dust in the operating environment of UPS may cause damage or lead to malfunction. The UPS should be always protected from the outside weather and sunshine. The recommended operating temperature is from +15 to +25 Celsius degrees.

## Inquiries

Address any inquiries about the UPS and battery cabinet to the local office or agent authorised by the manufacturer. Please quote the type code and the serial number of the equipment.

## 2 Introduction

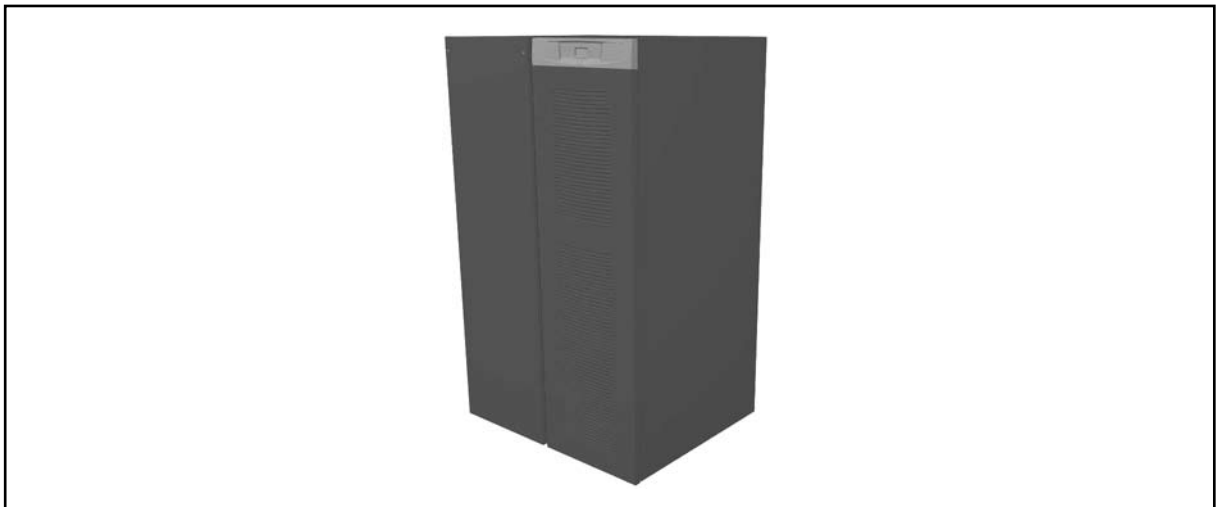
The product described in this manual is a transformerless Uninterruptible Power System (UPS). It is a true online, continuous duty, double conversion, solid state, three-phase system, providing conditioned and uninterruptible AC power to protect the customer's load from all nine power failures.

### System description

The UPSs are used to protect sensitive IT equipment and prevent loss of valuable electronic information, minimise equipment downtime, and minimise the adverse effect on production equipment due to unexpected power problems.

The UPS system continually monitors incoming electrical power and removes the surges, spikes, sags, and other irregularities that are inherent in commercial utility power. Working with a building's electrical system, the UPS system supplies clean, consistent power that sensitive electronic equipment requires for reliable operation. During brownouts, blackouts, and other power interruptions, batteries provide emergency power to safeguard operation.

The UPS system is housed in single freestanding cabinets. The cabinets line up and match in style and colour, and have safety shields behind the doors for hazardous voltage protection.



**Figure 1** UPS cabinet 20-40 kVA, 400 VAC 50/60 Hz, with an External Battery Cabinet.

### Feature: Active-Front Technology

Traditional input THD filters are no longer needed with this UPS product. The build-in advanced rectifier technology of UPS modules provides perfect sinusoidal input power quality at 0.99 input power factor with harmonic content less than 5% THD(i). This leads to more reliable total system operation and savings in generator and transformer sizing as losses in the windings are minimised.

Due to the active front rectifier, the UPS is comparable to a clean resistor load from the mains perspective. Thus, the high input power factor provides minimised cabling and fusing costs due to no reactive power consumption.

The low harmonic currents are due to high input power factor and provide the benefits:

- No additional losses in wires and cables
- No extra heating of transformers and generators with shortened service life
- No false circuit breaker tripping and malfunction
- No erratic operation of computers, telecommunication, monitors, electronic test equipment etc.
- No Resonance with power factor correction capacitors

## **Feature: Advanced Battery Management (ABM)™**

The ABM monitors the status of the battery and charges it only when the battery needs charging. This is the key to long battery life with the ABM due to low generation of corrosion inside the battery. It also monitors that the load never crashes because of bad or defected battery.

The main cause for corrosion is current flowing through battery. The more current going through battery, the shorter the battery life. Current flows through battery when it is discharged or charged. There is very little that can be done for discharging, because it depends on number of power outages in utility line.

The ABM is very valuable feature since most of the time battery does not need any charging. The charging is controlled and initiated on the following occasions:

- When turning the unit on
- After 18 days without charging
- If the open cell voltage decreases below predetermined voltage level

Hence, the function of ABM system is to prolong the battery life considerably compared to traditional system that uses float-charging technology. This means that there is no current going through batteries all the time and causing corrosion. In a traditional online UPS the inverter also causes ripple-current to be fed to batteries causing corrosion.

## **Feature: Hot Sync® technology**

The UPS product features U.S. #5,745,365 patented paralleling technology that provides N+X redundancy without introducing a single-point-of-failure. The products utilising the Hot Sync are completely autonomous and the only thing common among them is the critical output power bus.

The Hot Sync is 100% mathematical firmware that makes it more reliable than traditional paralleling techniques. Because the solution is implemented intrinsically, and Hot Sync is always active, the UPS modules do not know whether or not they are even in parallel.



A parallel UPS system means the linking together of two or more UPS units in parallel so that in the unlikely event one fails the other can automatically take up the load. Traditionally a parallel redundancy configuration is achieved by having a random or fixed master-slave relationship among the UPS units. This master logic gives out individual commands to all the slaves units. Unfortunately this can lead to a single-point-of-failure for the whole system because if the master logic or communication to slaves fails, and causes the whole UPS system to be in trouble.

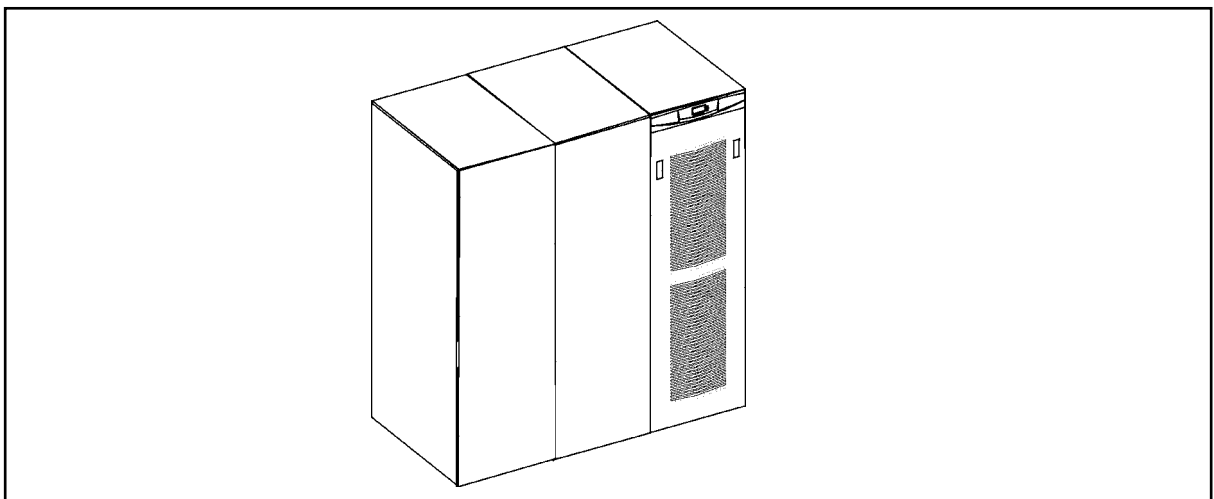
The Hot Sync® technology was developed to allow parallel capacity system and to maintain the highest system availability. An industry leading paralleling technology in its own right, the patented Hot Sync enables you to set up a parallel redundant system giving you 100% conditioned power at all times. Its unique digital design eliminates the system level single point of failure inherent in traditional parallel UPS modules, and exponentially increases the reliability of the overall system.

Hot Sync allows up to four UPS units to cover the same load in parallel and redundant configuration. No vulnerable master logic is needed in this patented design. It provides automatic load sharing and module level redundancy with nothing other than the power connecting the Hot Sync version of UPS modules.

## Basic system configuration

The following basic UPS system configurations are available:

- A single UPS system:
  - UPS cabinet with 0-4 battery strings      20-40 kVA
  - Runtime with internal batteries      20 kVA: up to 31 minutes  
30 kVA: up to 20 minutes  
40 kVA: up to 12 minutes
  - External battery cabinet      For longer runtimes
  - LCD display for easy configuration      Standard
- A parallel UPS system
  - Up to four units can be paralleled



**Figure 2** UPS configuration with two External Battery Cabinets.

Adding optional accessories can enhance the UPS system configuration. These include for example XSlot communication adapters.

### 3. Mechanical installation

The UPS and accessories are delivered on a specifically designed pallet that is easy to move with a forklift or a pallet jack. Keep the UPS always in upright position and do not drop the equipment. Do not either stack the pallets because of high-energy batteries involved and the heavy weight

#### Delivery check

The UPS is delivered with the following items:

- Plastic bag containing:
  - Quick Installation Guide, paper format, multilingual (coming later)
  - User's Guide, paper format, English language
  - User's Guide, CD-ROM format, multilingual (coming later)
  - Residual voltage warning stickers
  - Software Suite, CD-ROM format, English language
  - RS-232 serial cable for the Software Suite
- Delivery documents

#### Unpacking and visual inspection

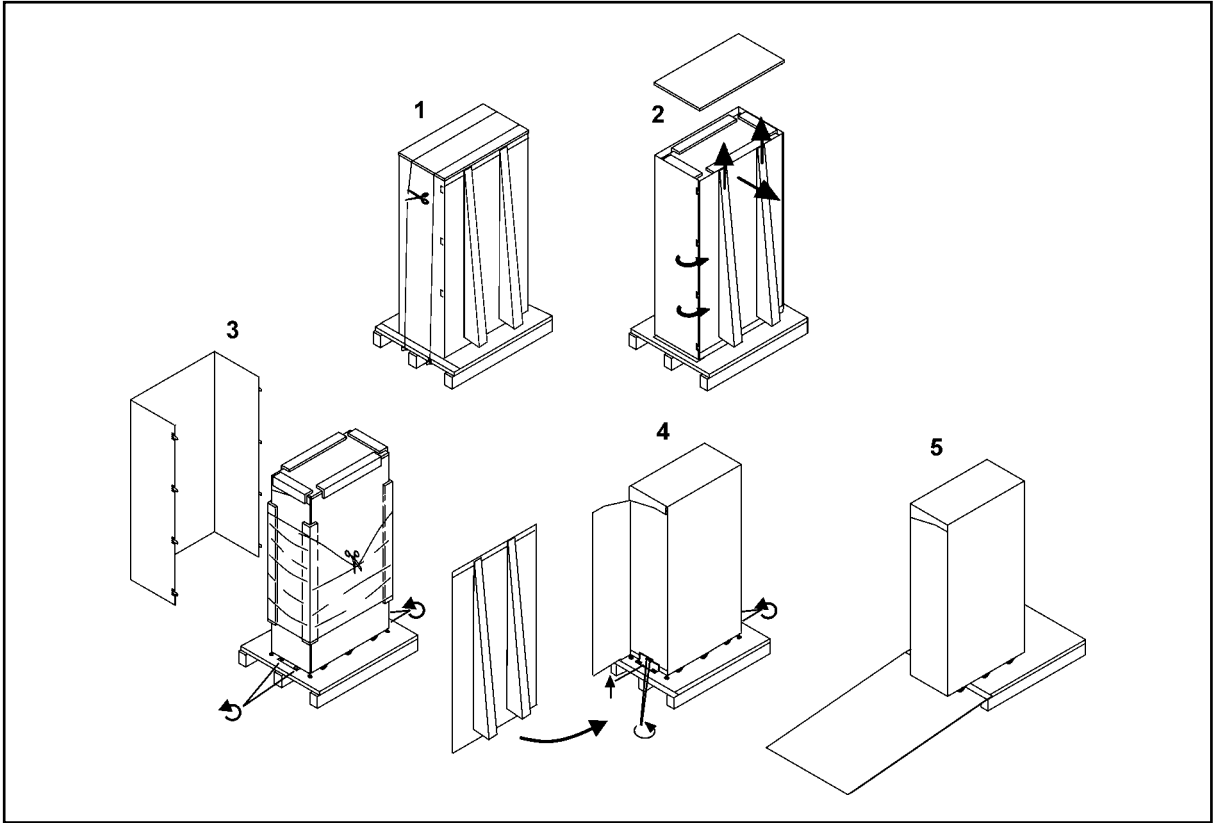
Check that there are no signs of shipping damages. The outside 'Tip&Tel' indicator should be intact if the equipment has been transported in the upright position.



#### Note!

**A claim for shipping damage must be filed immediately and the carrier must be informed within 7 days of receipt of the equipment. The packing materials should be stored for further investigation.**

Unpack the equipment by removing the packing and shipping materials. Make a visual inspection and check that the inside 'Drop&Tell' indicator is intact. Remove the equipment from the pallet and make sure that the floor surface is solid and suitable for the wheeling and heavy weight.



**Figure 3** Unloading the equipment from the pallet.

Check the information on the type designation label of the equipment to verify that the unit is of the correct type. The type designation label includes ratings, a CE marking, a type code, a part number and a serial number. The serial number is important when making inquiries. It allows individual recognition of the equipment.

## 4. Planning before installation

The equipment must be installed in upright position. The equipment requires space to front and back to enable cooling airflow. Service and maintenance require 500 mm clearance on right hand side. All cooling air enters at front and exits at unit rear. The required min. clearance from unit rear to an obstruction is 250 mm. Because the service and user access is in the front there should be reserved enough space (min 600 mm).

It is required to arrange ventilation of the UPS room. Sufficient amount of air cooling is needed to keep the max. room temperature rise at desired level:

- Temperature rise of max. +5°C requires the airflow of 600 m<sup>3</sup> per 1 kW of losses.
- Temperature rise of max. +10°C requires the airflow of 300 m<sup>3</sup> per 1 kW of losses.

An ambient temperature of 15 to 25 Celsius degrees is recommended to achieve a long life of the UPS and batteries. The cooling air entering the UPS must not exceed +40 °C. Avoid high ambient temperature, moisture and humidity.

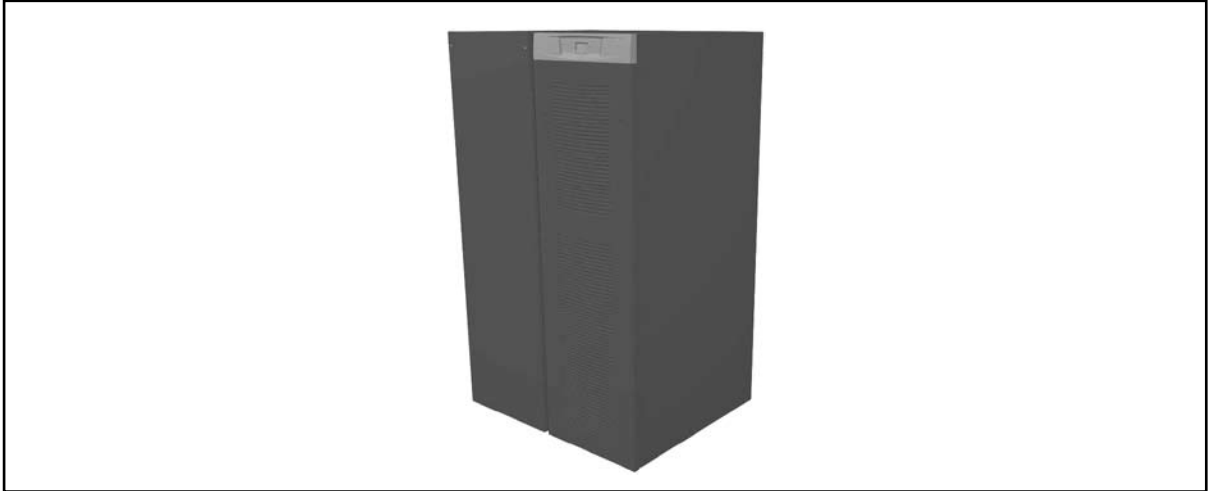
The floor material should be non-flammable and strong enough to support the heavy load. The UPS has (4) leveling feet that should be used when finalising the installation. The diameter of a single leveling foot is 29 mm.

Equipment	Weight	Point	Distributed	Note
	20-30 / 40 kVA	20-30 / 40 kVA	20-30 / 40 kVA	
UPS w/o BAT	200 / 217 kg	7.57 / 8.21 kg/cm <sup>2</sup>	531 / 576 kg/m <sup>2</sup>	No Batteries installed
UPS+1 BAT	300 / 317 kg	11.35 / 12 kg/cm <sup>2</sup>	797 / 842 kg/m <sup>2</sup>	1 Battery string installed
UPS+2 BAT	400 / 417 kg	15.14 / 15.78 kg/cm <sup>2</sup>	1063 / 1108 kg/m <sup>2</sup>	2 Battery strings installed
UPS+3 BAT	500 / 517 kg	18.92 / 19.56 kg/cm <sup>2</sup>	1328 / 1373 kg/m <sup>2</sup>	3 Battery strings installed
UPS+4 BAT	600 / 617 kg	22.71 / 23.36 kg/cm <sup>2</sup>	1594 / 1639 kg/m <sup>2</sup>	4 Battery strings installed
EXT BAT 0	150 kg	5.67 kg/cm <sup>2</sup>	401 kg/m <sup>2</sup>	No Batteries installed
EXT BAT 1	510 kg	19.29 kg/cm <sup>2</sup>	1362 kg/m <sup>2</sup>	1 Battery string installed
EXT BAT 2	870 kg	32.90 kg/cm <sup>2</sup>	2323 kg/m <sup>2</sup>	2 Battery strings installed

**Table 1** The floor surface must tolerate loading.

## 5. Cabinet installation

The required distance for UPS units next to each other is ten millimetres. The same applies to the optional battery cabinets that should be installed next to the UPS cabinet.



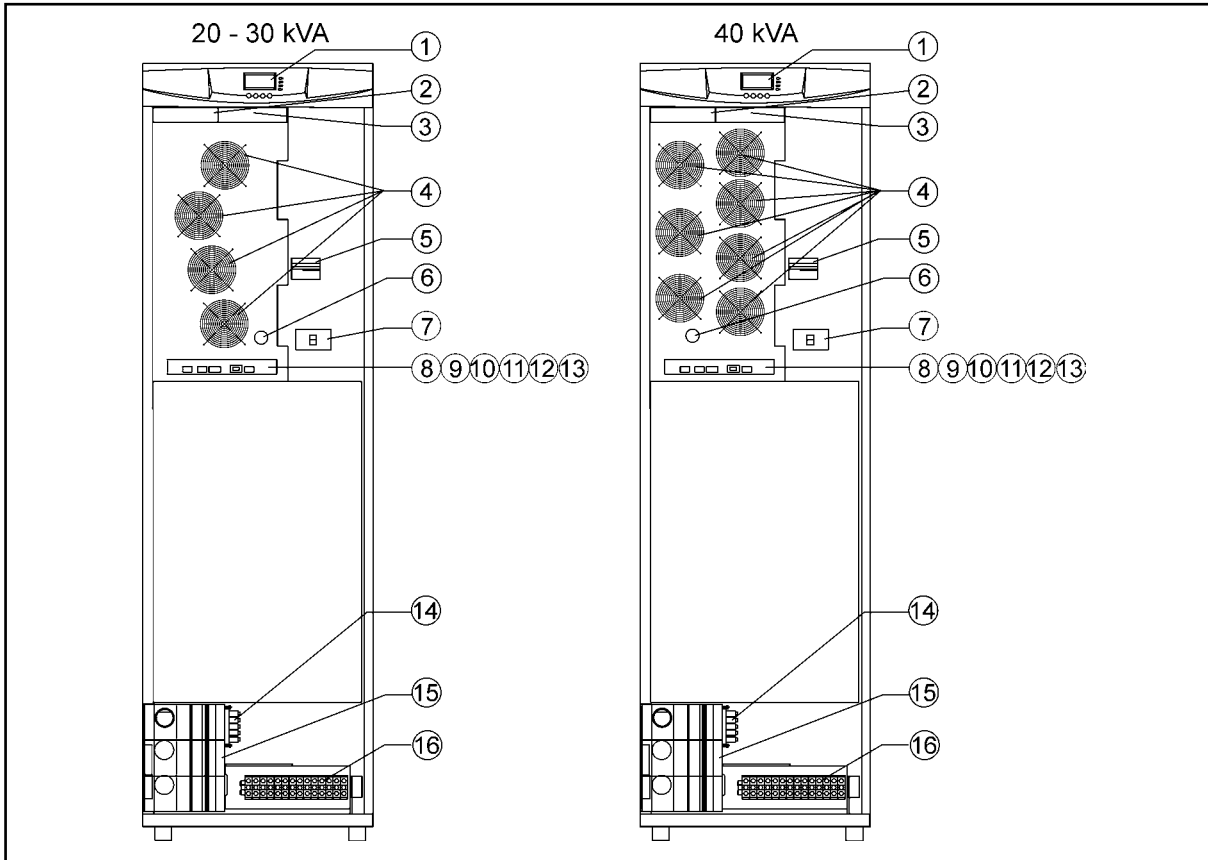
**Figure 4** UPS and external battery cabinets.



### Note!

**UPS cabinets can fall over if the shipping brackets are not used. Both rear and front shipping brackets must be used to secure the UPS cabinet to the floor.**

The UPS family has several alternative battery cabinets and configurations depending on the selected back-up time and quality of batteries.



**Figure 5** Powerware 9355 20-30 kVA and 40 kVA layout: 1:Graphical LCD; 2:XSlot-1; 3:XSlot-2; 4:Fans; 5:Input (rectifier) breaker (20-30 kVA)/switch (40 kVA); 6:Battery start button; 7:Battery breaker; 8-13: Connectivity terminals; 14:Ground terminal; 15:MBS; 16:Power cable terminals

## Maintenance bypass switch

The maintenance bypass switch (MBS) shall be mounted in the bottom of the UPS cabinet. It can be ordered factory installed.

## External battery cabinet option

It's recommended to install external battery cabinet(s) next to the UPS unit. The external battery can be placed on either side of the UPS unit, but it is recommended to instal on left hand side. Check before the installation that the battery voltage values in the type plate of the UPS and external battery cabinets are the same. The cables are delivered with the external battery cabinet.



**Warning!**

**The UPS contains high DC voltages. A qualified person must do the connections between the UPS and the external battery cabinet(s). The battery cabinet is connected electrically in parallel with the internal batteries of the UPS.**



**Warning!**

**If available, the internal battery has to be disconnected first because the external battery terminals may be hazardous due to parallel battery strings.**

## Battery racks

External battery racks shall be sized to take the voltage drop in the cable into account. To obtain support and help contact the local office or agent authorised by the manufacturer.

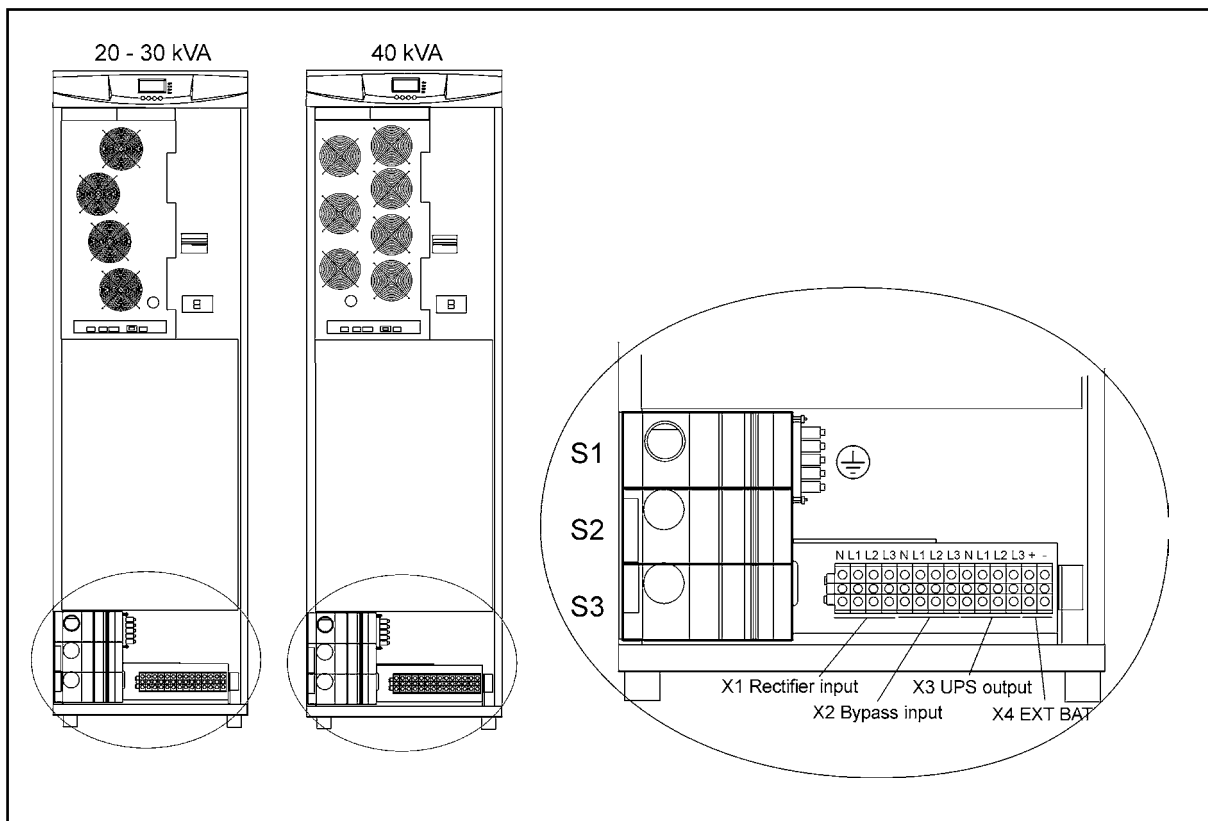
## 6. Electrical installation

The customer has to supply the wiring to connect the UPS to the local power source. The electrical installation procedure is described in the following text. The installation inspection and initial start up of the UPS and extra battery cabinet must be carried out by a qualified service personnel such as a licensed service engineer from the manufacturer or from an agent authorised by the manufacturer.



### Warning!

**Physical injury or death may follow, or damage may occur to the UPS, or the load equipment if these instructions are ignored.**



**Figure 6** Location of the power terminals. S1:Service Bypass Switch; S2:Static Bypass Input Switch; S3:UPS Output Switch. Disconnect all internal battery strings before operating with the terminal X4.



The UPS unit has the following power connections:

- **Three-phase** (L1, L2, L3), Neutral (N) and protective earth (PE) connection for the *rectifier input*
- **Three-phase** (L1, L2, L3), Neutral (N) and protective earth (PE) connection for the *bypass input* (N is common for rectifier and bypass inputs)
- **Three-phase** (L1, L2, L3), Neutral (N) and protective earth (PE) connection for the *load output*
- Plus (+), minus (-) and protective earth (PE) connection for the *external batteries*



**Note!**

**The rectifier requires a Neutral to operate. It's connected internally from the bypass terminal to the rectifier, see wiring diagram.**

## Power cables and protective fuses

Always use copper cable types to fit terminals with approx. 1.5 Nm torque for different load currents. The Cu cable sizing is based on multi-core cables laid in conduits/trunkings on the wall or on the floor (installation procedure C), ambient temperature 25°C, PVC insulation, surface temperature up to 70°C. Cables of several UPS can be installed in parallel to each other.

Standards SFS 6000-5-52 (2002) and IEC 60364-5-52 (2001-08) "Electrical installations of buildings" with normal 1.7 x Neutral conductor rating for IT loads are used as a sizing guide. For any other conditions, size the cables according to the local safety regulations regarding installation environment, appropriate voltage and currents of the UPS.

Fuses are sized according to local safety regulations, appropriate input voltage and the rated current of the UPS. Therefore, protect the input and bypass cables with gG (gL) fuses or B-C-D type of circuit breakers against overload and short-circuit.

Contact the manufacturer's authorised agent or the local office for assistance at fuse and cable sizing. Refer to the recommended cable and fuse ratings in the below table.

UPS rating		Input		Bypass		Load	I nom	PE	Battery
		Fusing	Cable	Fusing	Cable	Cable		Cable	Cable
20 kVA	3-phase	3x35 A	4x10 mm <sup>2</sup>	3x35 A	4x10 mm <sup>2</sup>	4x10 mm <sup>2</sup>	28.1 A	10 mm <sup>2</sup>	16 mm <sup>2</sup>
30 kVA	3-phase	3x50 A	4x10 mm <sup>2</sup>	3x50 A	4x10 mm <sup>2</sup>	4x10 mm <sup>2</sup>	42.1 A	10 mm <sup>2</sup>	16 mm <sup>2</sup>
40 kVA	3-phase	3x80 A	4x25 mm <sup>2</sup>	3x63 A	4x16 mm <sup>2</sup>	4x16 mm <sup>2</sup>	56.1 A	16 mm <sup>2</sup>	16 mm <sup>2</sup>
Maximum	3-phase	3x80 A	4x35 mm <sup>2</sup>	3x63 A	35 mm <sup>2</sup>	4x35 mm <sup>2</sup>		35 mm <sup>2</sup>	35 mm <sup>2</sup>

**Table 2** Minimum Cable and fuse ratings for the different UPS ratings with installation procedure C

## Wiring procedure

The power cable terminals are located in the bottom of the UPS unit. The service personnel is responsible for the correct electrical installation.

### The installation procedure:

1. Remove the cover plate(s) at the bottom or back of the UPS cabinet to make a route for input and output wires. Refer to the dimensional drawing for the correct location at the back of the unit.
2. Route the cables through the hole at the bottom or back of the unit. If more installation space is needed the lowest battery shelf can be removed temporarily.
3. Connect the conductors of the rectifier and bypass input cables to the proper terminals.
4. Connect the conductors of the load cable to the proper terminals.
5. Connect the conductors of an external battery cabinet cable to the external battery +, - and PE terminals. Check for the correct polarity. See also section External Battery Cabinet (EBC) installation procedure.



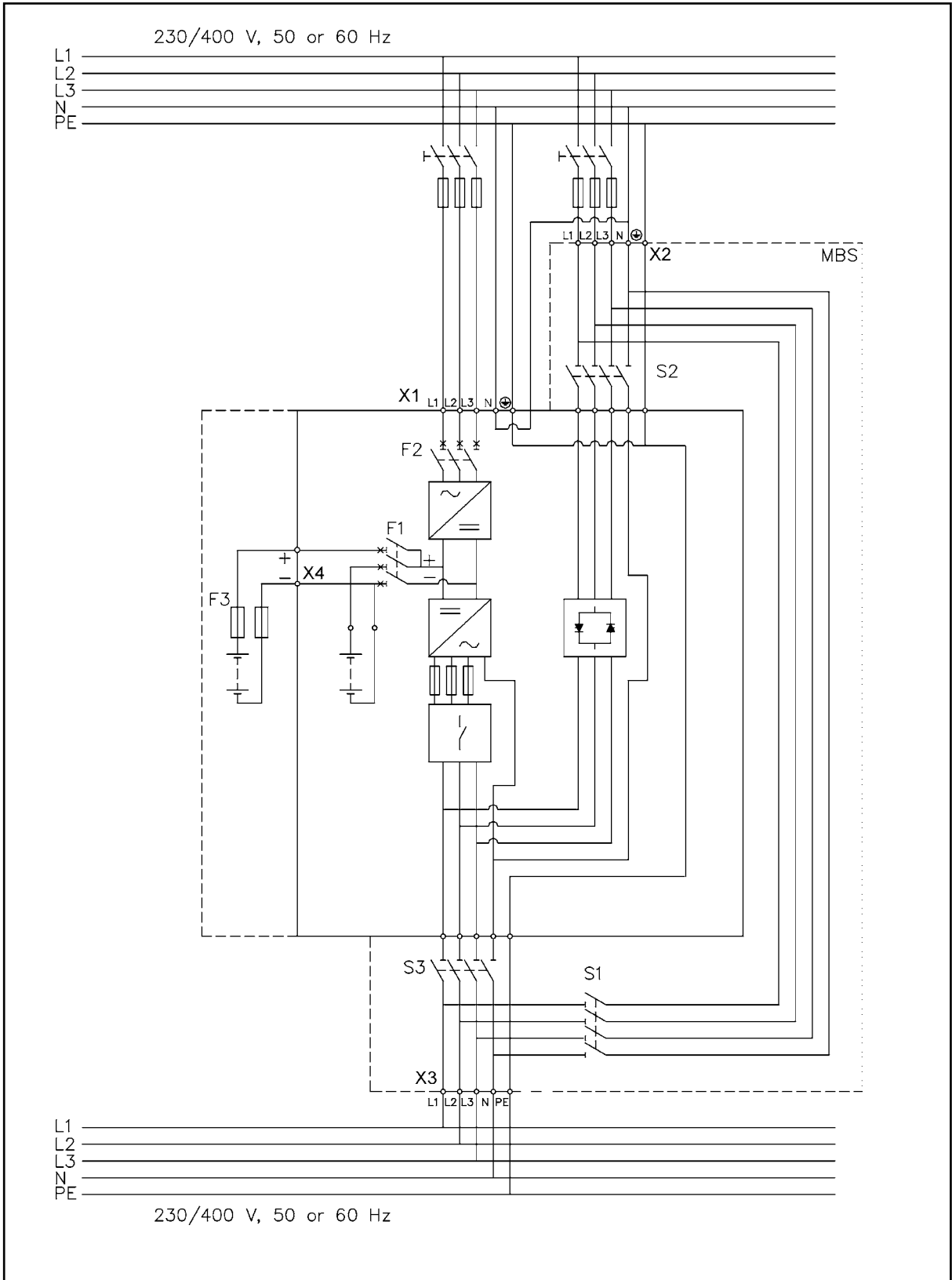
#### **Warning!**

**If available, the internal battery has to be disconnected first because the external battery terminals are hazardous due to the parallel battery string.**

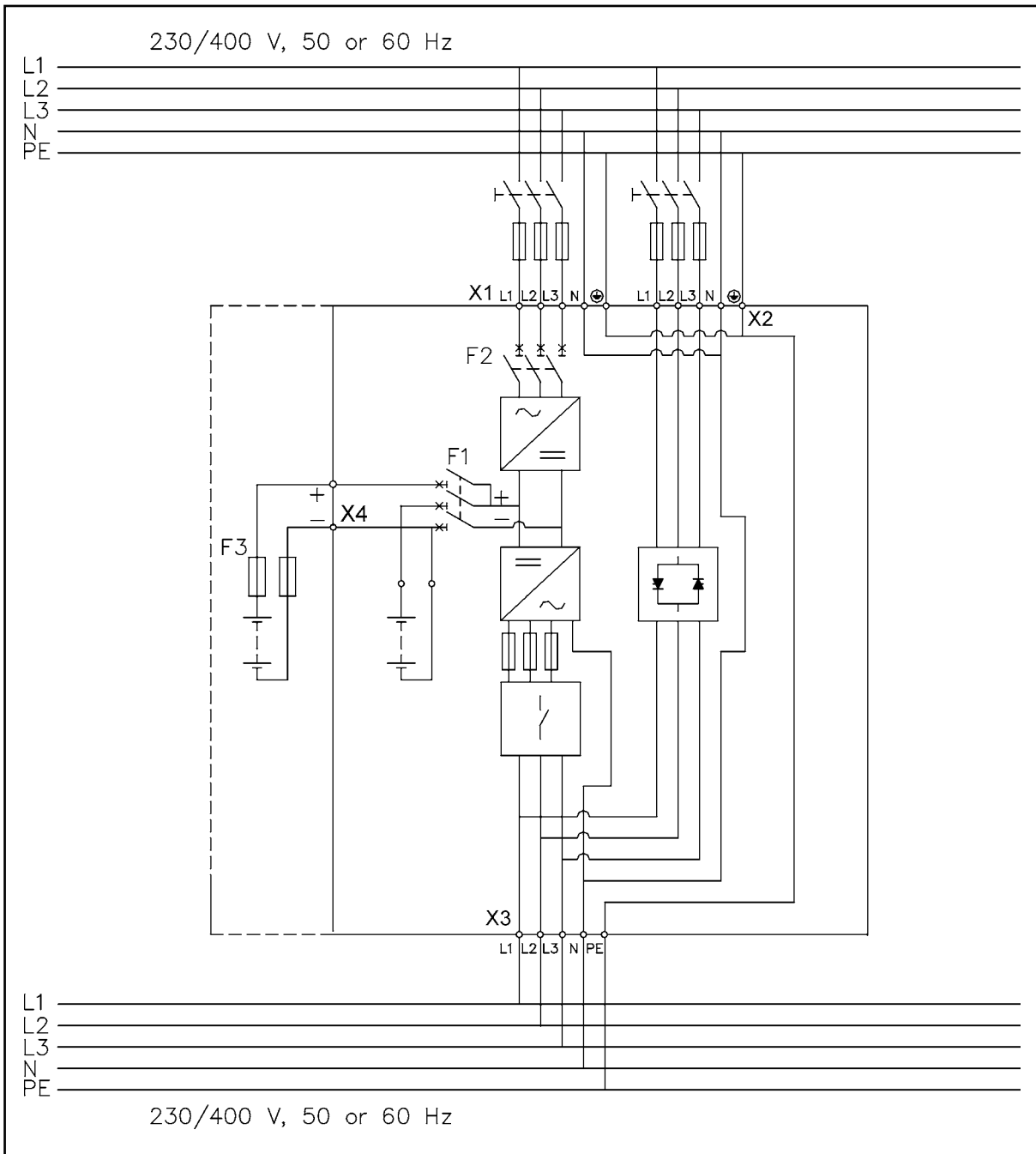
The IEC/EN 62040-1 safety instructions require the fitting by the user of a warning label on all primary power isolators installed remote from the UPS area. The warning label for electrical maintenance personnel shall carry the following wording or equivalent:

**“ISOLATE UNINTERRUPTIBLE POWER SUPPLY (UPS) BEFORE WORKING ON THIS CIRCUIT.”**

A readily accessible disconnect device shall be incorporated in the building installation wiring as shown in diagrams.



**Figure 7** Wiring diagram of UPS N-model with integral MBS.



**Figure 8** Wiring diagram of UPS N-model.

## External Battery Cabinet (EBC) installation procedure

The installation procedure is as follows:

1. The External Battery Cabinet (EBC) is recommended to be placed to left hand side of the UPS unit.
2. The required minimum distance for UPS unit and EBC is 10 millimeters, which is also required distance between two EBCs.
3. Turn F1 battery breaker from the UPS unit to OFF position.
4. Before connecting cables to the EBC disconnect one of the cables (+ or -) from each EBC's battery string and remove fuses from upper part of the cabinet. To be on the safe side, measure the voltage across the terminals to be 0 (zero).



### **Warning!**

**Turn F1 battery breaker from the UPS unit to OFF position and measure the voltage across the terminals (X4) to be 0 (zero) before any operations with terminal X4.**

5. When all the EBCs are connected parallel, measure the voltage across the terminals (X4) to be 0 (zero) and connect cables to terminal block X4 of the UPS unit.
6. After installation place removed fuses to original position, reconnect disconnected battery strings, check that the removed plates on right positions and turn breaker F1 to ON position.
7. Finally change the number of battery strings from User Settings.  
SETTINGS -> USER SETTINGS -> NUMBER OF BATTERY STRINGS.

## 7. Software and connectivity

The Software Suite CD-ROM that is bundled with the UPS contains software distributions and documentation in CD format. Furthermore, the comprehensive connectivity option portfolio includes Web/SNMP adapters for networked environments, Modem card for 24/7 remote monitoring, ModBus/Jbus card for building management system integration, relay interface cards for industrial and facilities use and RS-232 cards for serial communication to one or multiple computers.

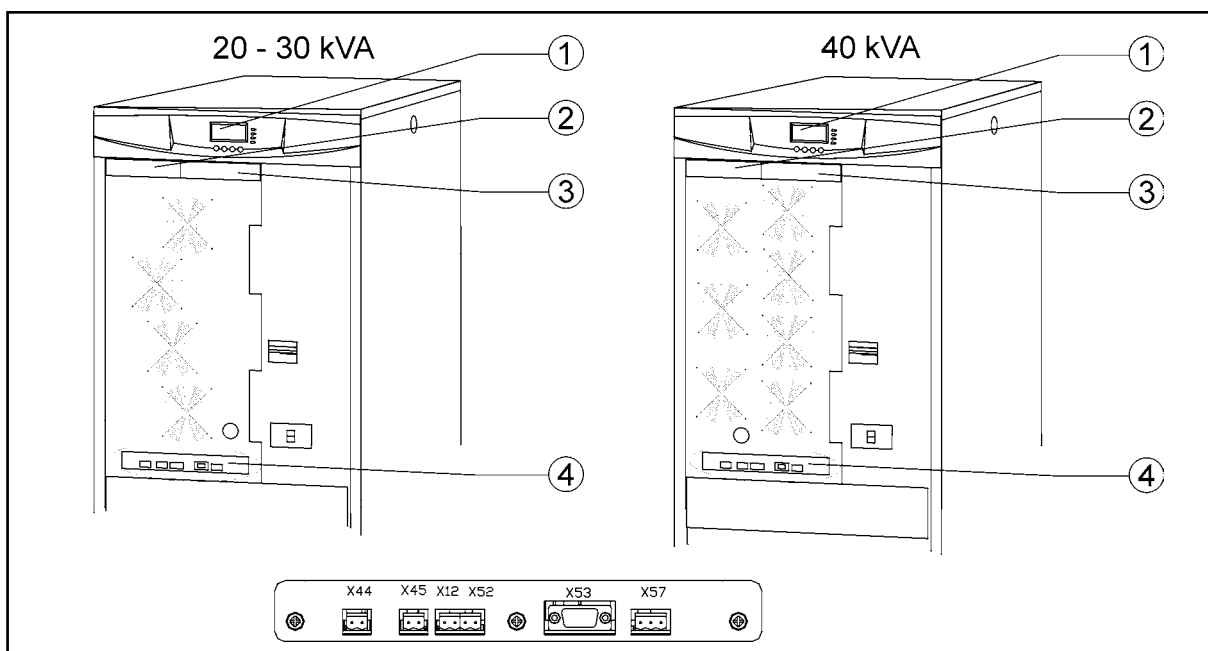
### Communication cables

It is recommended that the control cables and power cables be installed on separate trays. Where control cables will cross power cables make sure they are arranged at an angle as near to 90 degrees as possible.

All control cables shall preferably be shielded. If the shield is grounded, this shall take place on only one end of the cable.

The procedure for connecting the control cables is the following:

1. Remove the door by opening locks and lifting the door away of its original position.
2. Locate the control terminal or XSlot module where you want to install the communications cable.



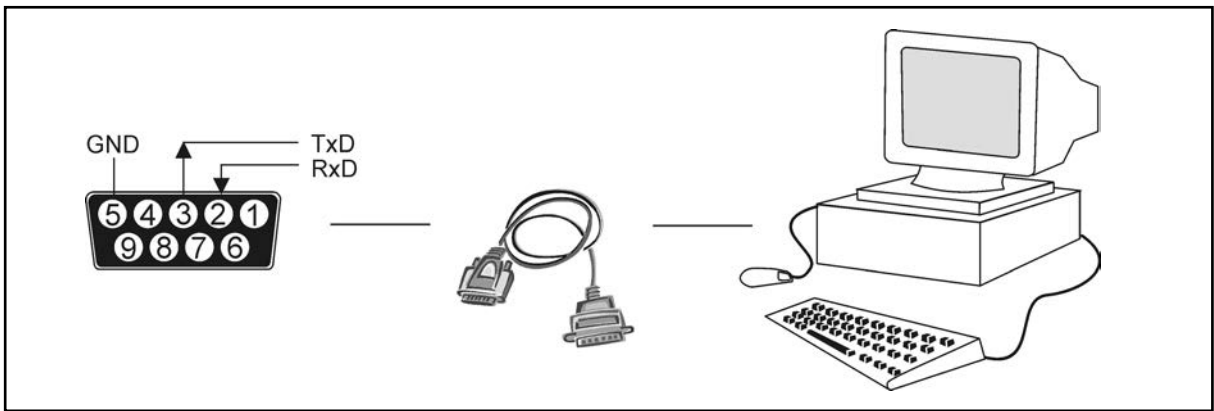
**Figure 9** Location of control cable terminals and LCD display: 1:Graphical LCD; 2:XSlot-1; 3:XSlot-2; 4: Signal inputs (X44 &X45); EPO (NC (X12) & NO (X52)); RS-232 (X53); Relay output (X57).

## Connection to the standard RS-232 port (X53)

The standard RS-232 interface uses 9-pin female D-sub connector. It shall be used with the delivered cable for a computer or external modem connection. The data is transmitted with XCP protocol that includes status and meters information about the UPS. The RS-232 port has the following format:

- Communication speed 19200 bps\*
- Data bits 8
- Parity None
- Stop bits 1
- Handshake None

\*Communication speed can be changed via LCD menu



**Figure 10** Identification of the interface port pins.

## LanSafe software

LanSafe software shuts down computers and whole networks in case of an extended power failure. It provides basic monitoring, data logging, notification and event actions for a single UPS solution. The software is bundled free of charge in Software Suite CD.

The connection procedure for the RS-232 interface port is following:

1. Connect the RS-232 communication cable to the computer.
2. Connect the RS-232 communication cable to the serial interface on the UPS.
3. Run the UPS software installation disk (Software Suite CD) on the computer.



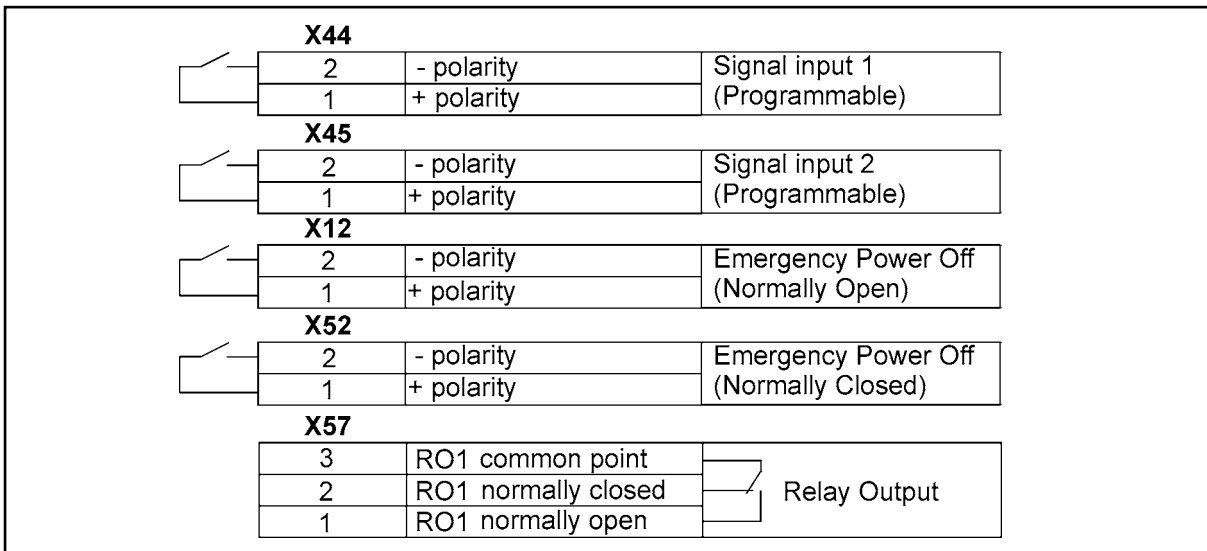
### Note!

**If communication does not work choose the correct bit rate from the LCD display. Please refer to the optional software documentation for appropriate bit rate settings.**

## External control connections

The UPS has an input/output interface for direct communication with your computer system. It is located behind the front door of the UPS unit. The cables connected to these terminals should be connected to cable clips.

Input and output terminals have a functional isolation from terminal to terminal. They are connected to the chassis through individual 1 MΩ resistors.



**Figure 11** External control cable connections to the UPS.



### Note!

**Pay attention to proper polarity if one is using a semiconductor switch type. A relay or other maintenance control is a preferred method.**

## Emergency Power Off (EPO)

This input is used to shut down the UPS from a distance. This feature can be used for emergency power down. There are two modes of operation, normally closed at X52 and normally open at X12. Remote shut down terminal X52 pins 1 and 2 are as factory default linked (X12 is open). When the loop on X52 is opened, the logic circuitry will immediately shut down the UPS output and open the battery breaker (F1).



### Note!

**EPO does not necessarily disconnect supply to load when unit is on internal or external bypass. Quaranteed disconnection of bypass supply has to be through a separate disconnect switch located in the supplying switchgear cabinet.**



In order to have the UPS running again pins 1 and 2 of connector X52 have to be reconnected and the UPS started manually. The pins must be shorted in order to keep the UPS running. Maximum resistance is 10 ohm. The EPO shall not be galvanically connected to any mains connected circuits. Reinforced insulation to the mains is required. See also "Start-up after EPO".

If the use of normally open EPO operation is desired, the loop on X52 has to be retained and the normally open EPO switch connected to X12. Operation is as above.

## Relay outputs

The UPS incorporates a programmable relay output with potential free contacts at X57 for remote alarm indications. It is rated for max. 30 VAC 1 A or 60 VDC 0,2 A nominal values. Additional (4) relay outputs can be obtained with the XSlot compatible AS/400 Relay Module. For more information, see the section "Using relay outputs".



### Warning!

**The relay contacts must not be directly connected to mains related circuits. Reinforced insulation to the mains is required.**

## Programmable signal inputs

The UPS incorporates two programmable inputs (X44, X45). Use of a non-polar (relay) control input is recommended. The pins must be shorted with maximum resistance of 10 ohm in order to activate the specific input.



### Note!

**Please note the polarity of the inputs as indicated in the external control connections if used with a polarity control.**

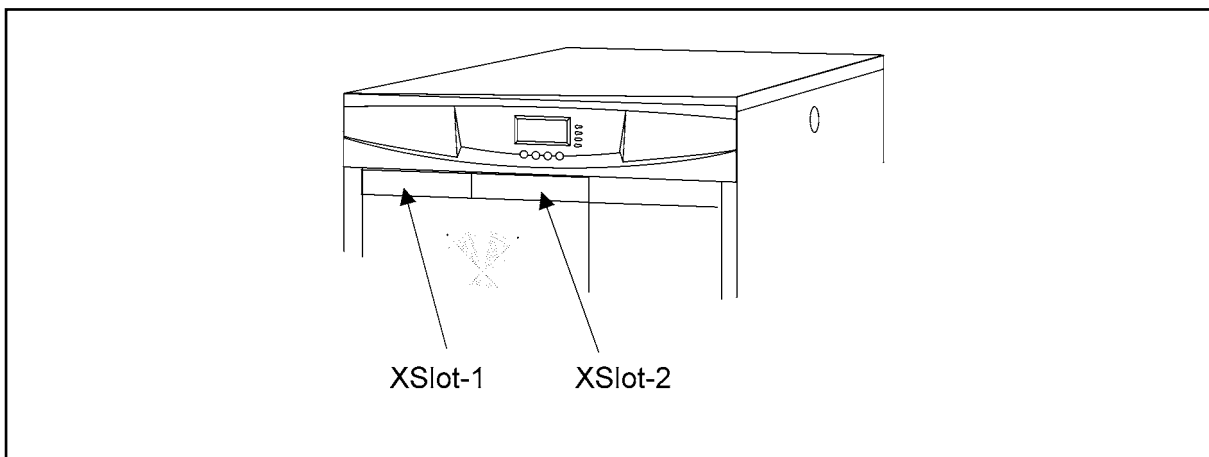
The default and programmable settings for the signal inputs are

- a) **Disable Bypass Operation**  
If active the automatic transfer to the static bypass is prevented.
- b) **Charger off**  
If active the batteries charging is disabled. In case of mains power outage the discharge of batteries is supported.
- c) **Remote ON/OFF**  
If active the UPS output turns off regardless of mode of operation. Auxiliary power, fan, communications and rectifier/battery charger shall remain functional. Restart initiated immediately when inactive.
- d) **Request Bypass**  
If active the UPS transfers to bypass if bypass voltage, frequency and synchronisation are ok.

- e) **Request Normal**  
If active the UPS transfers to inverter operation if not prohibited by EPO or alarm condition.
- f) **Force Bypass**  
If active the UPS is forced to static bypass operation regardless of the bypass status.
- g) **External Battery Breaker Status**  
If active the UPS knows that the batteries are disconnected.
- h) **Building alarm 1-6**  
These can be activated separately or at the same time with other building alarms.
- i) **Not in use (default)**
- j) **Shutdown**  
If active the UPS will shutdown immediately.
- k) **Delayed Shutdown**  
If active the UPS will shutdown after user configurable delay time. Restart initiated immediately when inactive.
- l) **Normal/Bypass**  
If active the UPS transfers to bypass if ok. If inactive the UPS transfers to inverter when possible.

## XSlot communication

XSlot modules allow the UPS to communicate in a variety of networking environments and with different types of devices. The UPS incorporates two (2) empty XSlot communication bays.



**Figure 12** Location of empty XSlot bays.

The UPS supports two serial communication devices according to the table below.

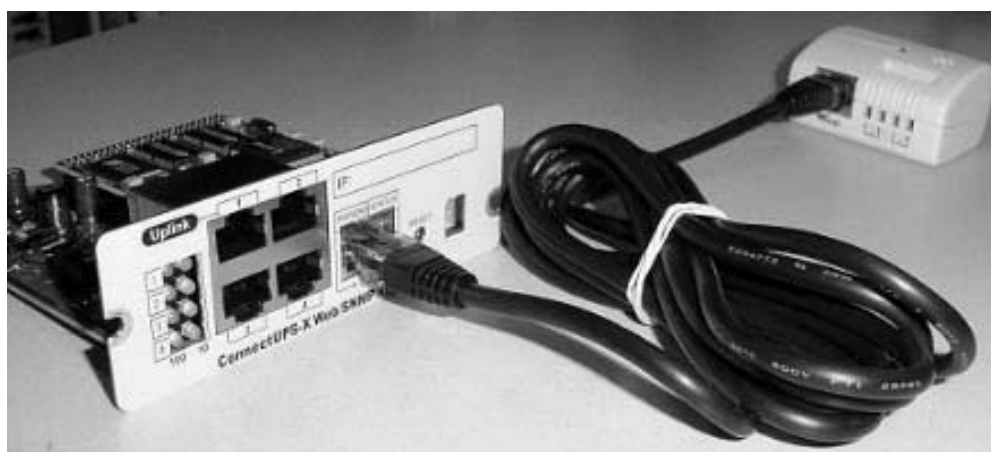
Configuration	Independent	Multiplexed	
	XSlot-1	Xslot-2	Std. RS-232 port
Default #1	Any XSlot Module	Any XSlot Module	Not in use
Default #2	Any XSlot Module	Relay Module	Available
Default #3	Any XSlot Module	Not in use	Available
Default #4	Any XSlot Module	Hot Sync card	Available

**Table 3** Typical XSlot configurations for UPS communication.

### Web/SNMP Module (optional)

The module supports HTTP and SNMP compliant remote monitoring and shutdown for the protected computer systems. It can be connected to a twisted-pair Ethernet network (10/100BaseT) using an RJ45 connector.

The Web/SNMP module has a build-in switching hub that allows three (3) additional network devices to be connected to the network without the requirement of additional network drops. In addition, an Environmental Monitoring Probe (EMP) can be requested from the UPS manufacturer to obtain humidity, temperature and two relay inputs. It is connected to the communication port of the Web/SNMP module as option.

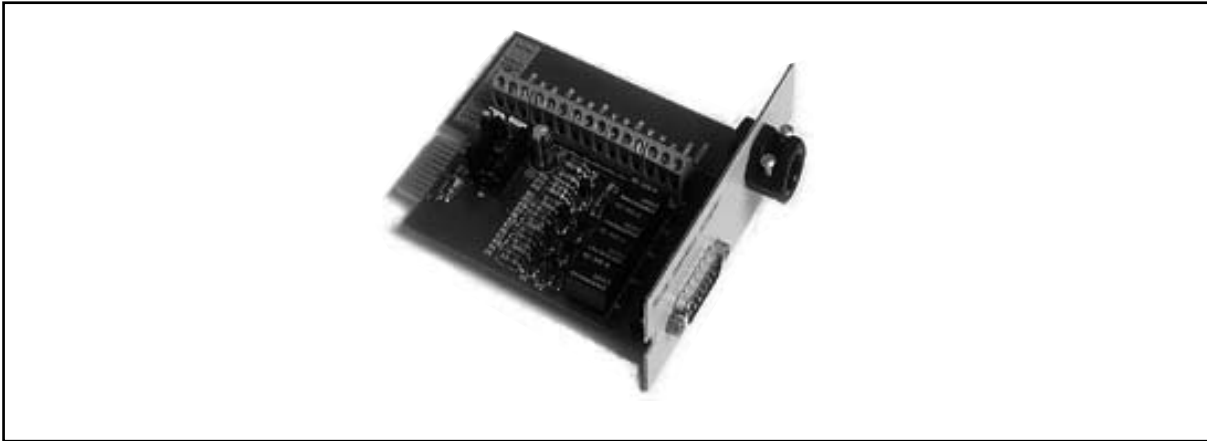


**Figure 13** ConnectUPS-X SNMP/Web Module and Environmental Monitoring Probe (EMP).

### AS/400 Relay Module (optional)

The Relay Module provides potential free relay interface for AS/400 connected computers and industrial applications. The relay interface supports both 15-pin D-sub connector and terminal block connections up to four (4) potential free relays.

The relay contacts are rated for 1 A, 30 Vac or 200 mA, 60 Vdc, and they have a galvanic isolation from the other circuits of the UPS unit.



**Figure 14** AS400 Relay Module.

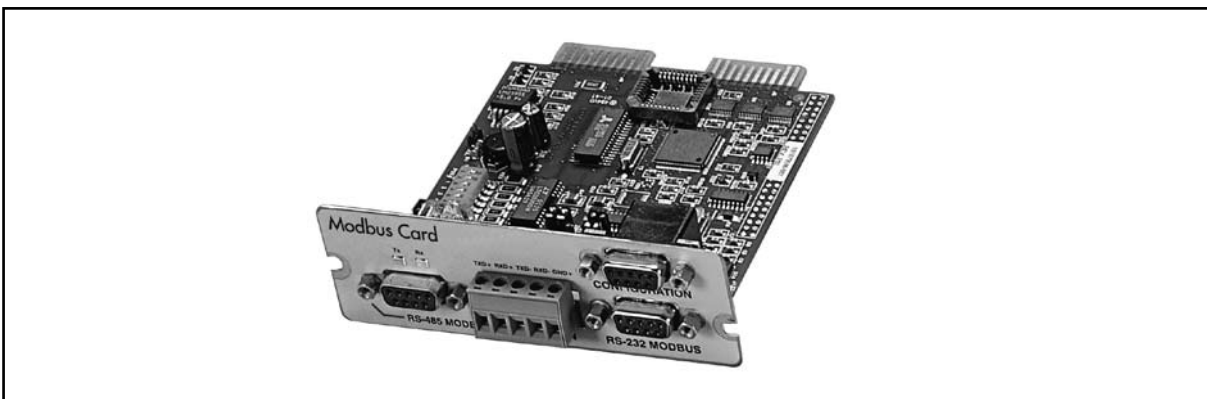
### **Single Serial Port Module (optional)**

To establish communication between the UPS and a computer, connect your computer to the UPS communication port using the supplied communication cable.

When the communication cable is installed, power management software can exchange data with the UPS. The software polls the UPS for detailed information on the status of the power environment. If a power emergency occurs, the software initiates the saving of all data and an orderly shutdown of the equipment.

### **Modbus/Jbus Module (optional)**

The Modbus module provides monitoring and integration to the Building Management Software (BMS) such as Wonderware. It features continuous and reliable communication through isolated DB9 ports (RS485/RS232) or a terminal strip (RS485).



**Figure 15** Modbus/Jbus Module.

## 8. User operations

The UPS has a four-button graphical LCD with backlight. It provides useful information about the unit itself, load status, events, measurements, and settings.

The LCD backlight is switched on by pressing any button. It has a timeout that automatically switches off after 15 minutes of inactivity.

### Display functions

As default and after 15 minutes of inactivity the UPS is showing the selectable start screen:

1. Logo screen (Product name)
2. Mimic screen (See User Settings on LCD screen)

The screen backlit has automatic shutdown after long period of inactivity. It will light up once a button is pushed. The right side button will initiate the text to the screen. The scrolling through the menu structure is done with buttons indicated by the  $\uparrow$   $\downarrow$  images of the LCD screen. The menu structure is shown in the table below. There are small differences in the menu structure between single and parallel mode.

Parallel Mode	Single Mode	Main Menu	Submenu	Menu functions
x	x	UPS STATUS	->	UPS off / System normal / UPS supporting load / UPS on battery / UPS on bypass / +active alarms and notices / +battery status (resting, charging, floating, not connected, discharging)
x	x	EVENT LOG	->	Notice / Alarm
x	x	MEASUREMENTS	PARALLEL SYSTEM	Parallel unit 1...4 kW/Parallel total kW
			OUTPUT	Voltage / Current / Frequency / Power
			BATTERY	Voltage / Current / Runtime
			INPUT	Voltage / Current / Frequency
			BYPASS	Voltage / Frequency
x	x	CONTROL	->	Goto bypass / Battery test / Display test / Reset error state
x	x	SETTINGS	USER SETTINGS	Date / LCD contrast / Change language / Relay config / Signal inputs / Serial port config / Parallel operation settings / Start screen / User password / Audible alarms / Battery charging method / +list of std. settings
			SERVICE SETTINGS	Adjust parameters / Adjust events / Reset custom / Clear history / + modem call settings
x	x	IDENTIFICATION	->	UPS Type / Part nro. / Serial nro / Revisions
	x	TURN UPS ON	->	-
	x	TURN UPS OFF		
x		TURN SYSTEM ON		
x		TURN UPS OFF		
x		TURN SYSTEM OFF		

**Table 4** Menu map for display functions.

## User Settings

The UPS has the following typical settings that are user configurable. Note that some of the settings become effective at the next start-up of the UPS. User settings can be configured via the front panel. Select: SETTINGS -> USER SETTINGS.

Description	Available settings	Default setting
<b>General:</b>		
Display contrast adjustment	+ / -	Moderate
Display language	[English], [Spanish], [French], [German]	English (British)
Date & time	[xxxx-xx-xx]	0001-01-01
Audible alarms	[Normal], [Disabled]	Normal
Normal screen in display	[logo], [mimic]	Product name
User settings password	[Not required], [Set]	Not required
<b>Nominal values:</b>		
Nominal output voltage (L-N)	[220], [230], [240]	230 Volts
Nominal output frequency	[50 Hz], [60 Hz]	50 Hz
Rectifier phase current limit	Step: 1 A	56 / 72 A
<b>Communication and connectivity:</b>		
Disable control commands	[Enabled], [Disabled]	Disabled
Communication speed	[1200], [2400], [9600], [19200]	19200 bps.
Std. relay output function	[UPS ON/OK], [Custom], [Battery low], [System on bypass], [System on battery]	UPS ON/OK
Signal input #1-2 function	[Empty], [see Signal inputs]	Empty
Hardware remote off delay for hardware Remote off with restart function.	Step: 1 sec.	120 sec
XSlot relay output 1-4 function	[Nothing], [see Signal inputs]	XSlot defaults: #1: on battery #2: battery low #3: UPS on/ok #4: on bypass
XSlot input signal (long break via Rx)		Nothing
XSlot shutdown signal activation delay before the signal is accepted.	Step: 1 sec.	5 sec
<b>Bypass and synchronisation:</b>		
Usage of bypass	[Enabled], [Disabled]	Enabled
Require synch at transfer on bypass	[Required], [Not Required]	Not required
Transfer on bypass on overload	[Immediately], [after delay]	Immediately
Synchronization enable	[Enabled], [Disabled]	Enabled
Bypass voltage deviation high limit	+1% ... +20%, step: 1%	+10%
Bypass voltage deviation low limit	-1% ... -20%, step: 1%	-15%
Synchronization window	0.5 ... 3.0 Hz, step: 0.1 Hz	±2.0 Hz
Frequency slew rate (not in parallel mode)	0.1 ... 3.0 Hz/s, step 0.1 Hz/s	0.2 Hz/s

<b>Battery information and settings:</b>		
ABM charging cycling disable	[Enabled], [Disabled]	Enabled
Charging temp compensation	[Enabled], [Disabled]	Enabled
Battery size setting	Step: 1 Watts/cell	24 Watts/cell
Number of 36 pcs. battery strings	0 (no batteries), 1, 2, 3, 4...	1 string
Battery low alarm level	Step: 0.01 V/cell	1.88 V/cell
Automatic battery support test	[Enabled], [Disabled]	Enabled
Maximum charging current	Step: 0.1 A [max. 25 Amps]	6 Amps
Output on, automatic delay time before turning the output on	[Disabled], [Set delay, step: 1 sec]	0 sec.
Output off, automatic delay time on battery after which output is turned off	[Disabled], [Set delay, step: 1 sec]	Disabled
<b>User preferences:</b>		
Operation priority while rectifier input break	[On battery], [On bypass]	On battery
Site wiring fault w/ wrong Neutral connection	[Enabled], [Disabled]	Enabled
Power Strategy	[Standard], [High Efficiency]	Standard
<b>Parallel settings:</b>		
Parallel unit number	[Single unit], [Unit #1], [Unit #2], [Unit #3], [Unit #4]	Single unit
Parallel operation mode	[Redundant mode], [Capacity mode]	Redundant mode
Synchronization	[Enabled], [Disabled]	Enabled
Start auto calibration		
Parallel XCP	[System], [Unit]	System
Minimum units to support load	[0], [1], [2], [3], [4]	2

**Table 5** User setting in the LCD menu screen.

## Changing language

Pressing and holding down the first button on the left for about 3 seconds is a shortcut to the language menu. This action is possible from any LCD menu screen.

The default firmware has four main languages: English, Spanish, French and German. Other local language packages including Chinese, Greek and Russian can be requested from the local service representative.

## Using relay outputs

Relay outputs can be used for remote alarm indications.

Each relay has four standard pre-programmed settings for alarms:

- On bypass, UPS ok, battery low and on battery

One of the standard relay setting is 'Custom', which can be customised by the user.

The procedure to customise alarms:

1. Push any key of the control panel to enable the functions on the LCD screen.
2. First select "SETTINGS", then "USER SETTINGS" and finally "RELAY CONFIG" from the LCD menu.
3. Select the relay what is needed to be configured (ALARM-1 is fixed relay output X57).
4. Select "empty" to clear old settings.
5. Select "custom" and activate needed alarms with the button on the right.
6. After the selection press "OK" button.
7. Finally test that UPS alarms correctly.

## Normal start-up

Check the mechanical and electrical installation of the UPS before start-up. Go through the checklist below together with another person.

### Check

- Read the attached safety manual before you work on the unit.
- The unit is fixed according to maintenance installation
- The ambient conditions are within specification.
- The cooling air will flow freely.
- The UPS is grounded properly.
- The input and bypass voltages match the UPS nominal voltage.
- The input, bypass, battery and output terminal connections are OK
- Appropriate input and bypass fuses and disconnectors are installed.
- Appropriate backfeed warning sign for disconnectors are installed.
- Appropriate cables sizes are used.
- The external control connections inside the UPS are OK.
- There are no tools, foreign objects or dust inside the UPS from the installation.
- Covers are in place.
- Optional MBS is placed to UPS position as default.



You are then ready to proceed with the starting up the UPS:

1. Turn the battery breaker (F1) and input circuit breaker/switch (F2 MAINS 63A/F2 MAINS 125 A) to ON position.
2. UPS will enter a stand-by mode and starts to charge batteries with coolings fan operational. Output is without the voltage in the stand-by mode.
3. Push any key of the control panel to enable the functions of the LCD screen
4. Select "TURN UPS ON" from the LCD menu (see: Display Functions)
5. Press and hold ↵ button for 2 sec. There is a "ticking" sound during the hold.

The UPS shall check its internal functions, synchronise to bypass and start to supply the load. The green LED is blinking if there occurs an active notice. In normal operation the green LED is constantly lit if no new active notices present.

The output voltage shall be verified from the output measurements screen of the LCD. If there is voltage in the output then UPS is supplying the load.

## Battery start-up

UPS will start on battery if mains is not available. Note that the UPS behaviour may be slightly different from the normal start-ups. In battery start-up battery breaker need to be closed and a green battery start button (on the left hand side of the battery breaker) pressed till display lits up.

## Start-up after EPO

1. Find out the reason that caused EPO
2. Check that there are no risk to start the UPS again
3. Follow Normal start-up check list and procedure

## Shutdown

The procedure to shutdown from LCD is following:

1. Push any key of the control panel to enable the functions of the LCD screen
2. Select "TURN UPS OFF" from the LCD menu (see: Display Functions)
3. Press and hold ↵ button for 5 sec. There shall be an indication sound during the hold.
4. UPS will enter a stand-by mode and continues charging batteries with a cooling fan operational. Output is without the voltage in the stand-by mode.
5. Press and hold ↵ button for 5 sec. There shall be an indication sound during the hold.
6. UPS shall do a shutdown routine.
7. Turn the battery breaker (F1) and input circuit breaker/switch (F2) to OFF position to finalise the shutdown procedure.



**The behaviour is different if UPS is turned off from the programmable input or through communication cards. If battery and input circuit breakers are left ON, UPS will enter a stand-by mode and starts to charge batteries with a cooling fan operational. Output is without the voltage in the stand-by mode.**

## 9. Maintenance

All operations inside the unit must be performed only by a service engineer from the manufacturer or from an agent, authorised by the manufacturer.

The troubleshooting procedure gives simple remedial if a malfunction occurs in the UPS. The operator should start the trouble shooting if there is an active alarm indicated on the LCD screen. Service should be contacted if the active alarm is abnormal and displayed as a service code.

Call service if you are not able to solve the problem.

LCD display	Description	Action
Overload	The connected load needs more power than the UPS is rated to provide. The inverter or static bypass is supplying the excessive load level.	Shut down the least important load that is connected to the UPS. The UPS should switch back to normal operation once the load level is acceptable.
Battery test failed	Your batteries are detected to be faulty.	Batteries should be replaced and you need to contact the local office or representative of the UPS manufacturer.
Battery low	The UPS is operating in stored energy mode. It will shut down soon due to low battery voltage.	Make controlled shutdown of the protected load immediately to prevent loss of data.
On battery	The UPS is operating in stored energy mode.	Save your data and perform a controlled shutdown of your load.
Overtemperature	High UPS temperature is detected.	Check that fans are operational and ventilation holes are not blocked. Make sure the ambient temperature is not excessive

**Table 6** Typical alarms displayed in the LCD screen of the UPS unit.

### Regular service/intervals

The UPS requires very little maintenance if installed in an appropriate environment. In order to ensure maximum availability of the UPS, manufacturer recommends signing a proactive service agreement with a local authorised service provider.

Maintenance	Interval
Batteries change	~ 3-5 years / service
Batteries test	~ 18 months / service
Cooling fan change	~ 5 years / service

**Table 7** Routine maintenance intervals recommended by the manufacturer.

## Batteries

The condition of the batteries is crucial for operation. The UPS will indicate by audible and visual alarms if the capacity of the battery bank has decreased. The UPS units are provided with the automatic battery test and ABM management function to continuously monitor the condition of the battery bank.

Servicing of batteries should be performed or supervised by personnel knowledgeable about batteries and required precautions. When replacing batteries, replace with the same type and number of batteries.



### Note!

**Do not dispose of batteries in a fire. The batteries may explode.  
Do not open or mutilate batteries. Released electrolyte is harmful to the skin and eyes. It may be toxic.**

## Cooling fan

The cooling fan lifespan of the UPS unit is about 60 000 operating hours. The actual lifespan depends on the environment and ambient temperature.

Fan failure can be predicted by increasing noise from the fan bearings. The fan replacement is recommended once this symptom starts appearing.

Do not use other than manufacturer's specified spare parts.

## LED Indicators

The UPS unit has (4) LEDs to indicate the status.

Graphical sign	LED	Description	Note
	Green	UPS status is ok.	Blinking when a new notice message is active.
	Yellow 1	UPS is in battery mode	
	Yellow 2	UPS is in bypass mode	
	Red	UPS has an active alarm	Blinking when new alarm is not reset and still active.

**Table 8** Description of the LED indicators.

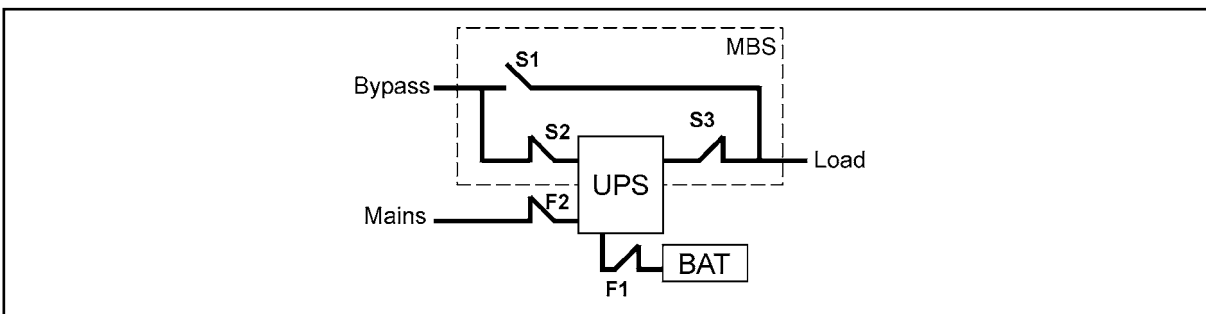
## Maintenance bypass switch (MBS) operation

The maintenance bypass switch may be as standard or as optional in your system depending on the ordered configuration. The operation of the MBS is allowed for a trained person only who is familiar with the UPS behaviour and functions. The full UPS wiring diagram with a MBS switch is presented in the installation part of the manual. The MBS is located in the bottom of the UPS near power terminals



### Note!

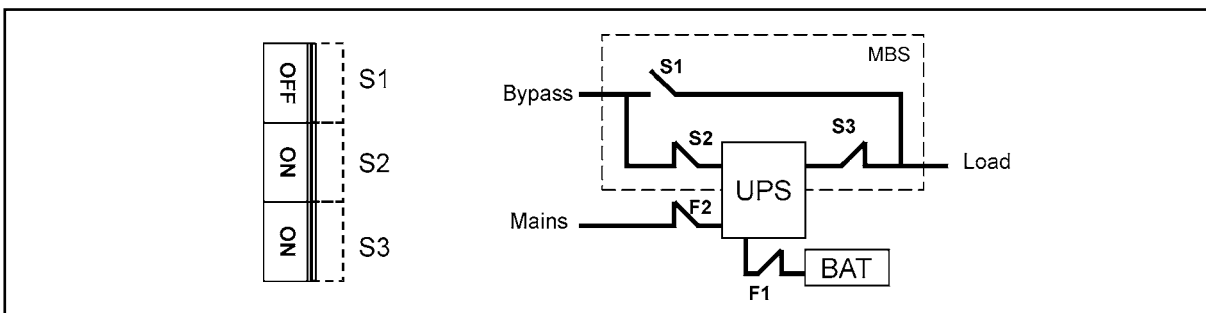
The MBS consist of three switches and failure to understand the correct sequence may drop the critical load.



**Figure 16** The normal positions of the three MBS switches.

### Turn UPS from normal mode to maintenance bypass mode (service bypass mode)

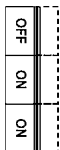
The procedure to turn the UPS to maintenance bypass switch is described below.



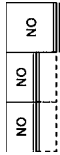
**Figure 17** The normal (UPS supplying the load) positions of the three MBS switches.

### No break transfer from normal mode to Service Bypass:

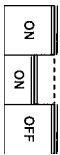
1. The normal start position should be following:



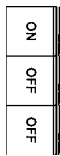
2. Use LCD to turn the UPS on internal static bypass mode. Select: CONTROL -> GOTO BYPASS MODE. Remember to verify the transfer before proceeding the next step.
3. Remove the locking plate of the S1-3 switches.
4. Turn ON the S1 switch to bypass UPS:



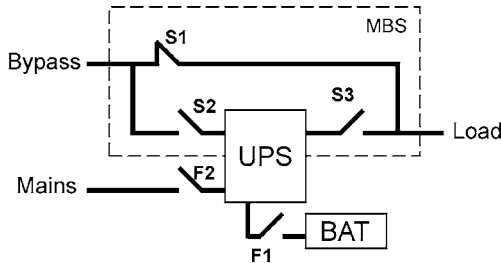
5. Turn OFF the S3 switch to disconnect UPS output:



6. Use LCD to turn UPS OFF.
7. Turn **F1** battery breaker and **F2** input to OFF position.
8. Turn OFF the S2 switch to disconnect UPS bypass input:

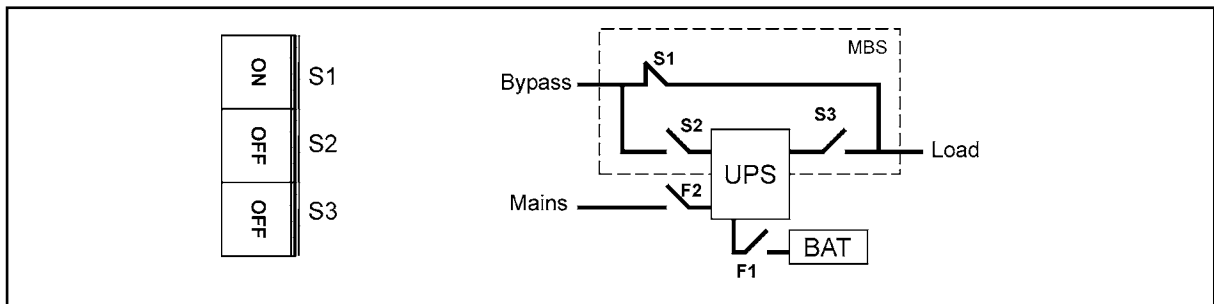


9. Remount the locking plate of the S1-3 switches to the position to prevent the use of them.
10. UPS is now in the maintenance bypass mode, see below:



### Turn UPS from maintenance bypass to normal mode

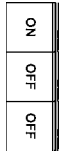
The procedure to turn the UPS back to normal mode is described below.



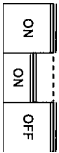
**Figure 18** The service (bypass supplying the load) positions of the three MBS switches.

**No break transfer from Maintenance Bypass to normal mode:**

1. The normal start position should be following:

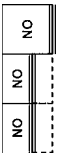


2. Turn ON S2 switch to connect bypass input to UPS:

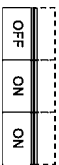


3. Turn the F1 battery breaker and F2 input breaker/switch to ON position.
4. Use LCD to “Turn UPS on” and wait until fully started.
  - Make sure the UPS is not displaying alarms or notices alarm with the green LED lit.
  - You may verify the output voltage from the meters screen of the LCD.
5. Use LCD to transfer the UPS to internal static bypass. Remember to verify the transfer before proceeding the next step.

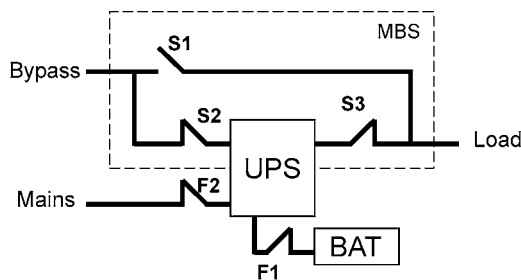
6. Turn ON S3 switch to connect UPS output to load:



7. Turn OFF S1 switch to disconnect bypass output:



8. Use LCD to transfer the UPS to normal mode. Select: CONTROL → GOTO NORMAL MODE.
9. UPS is now in Normal mode, see below:



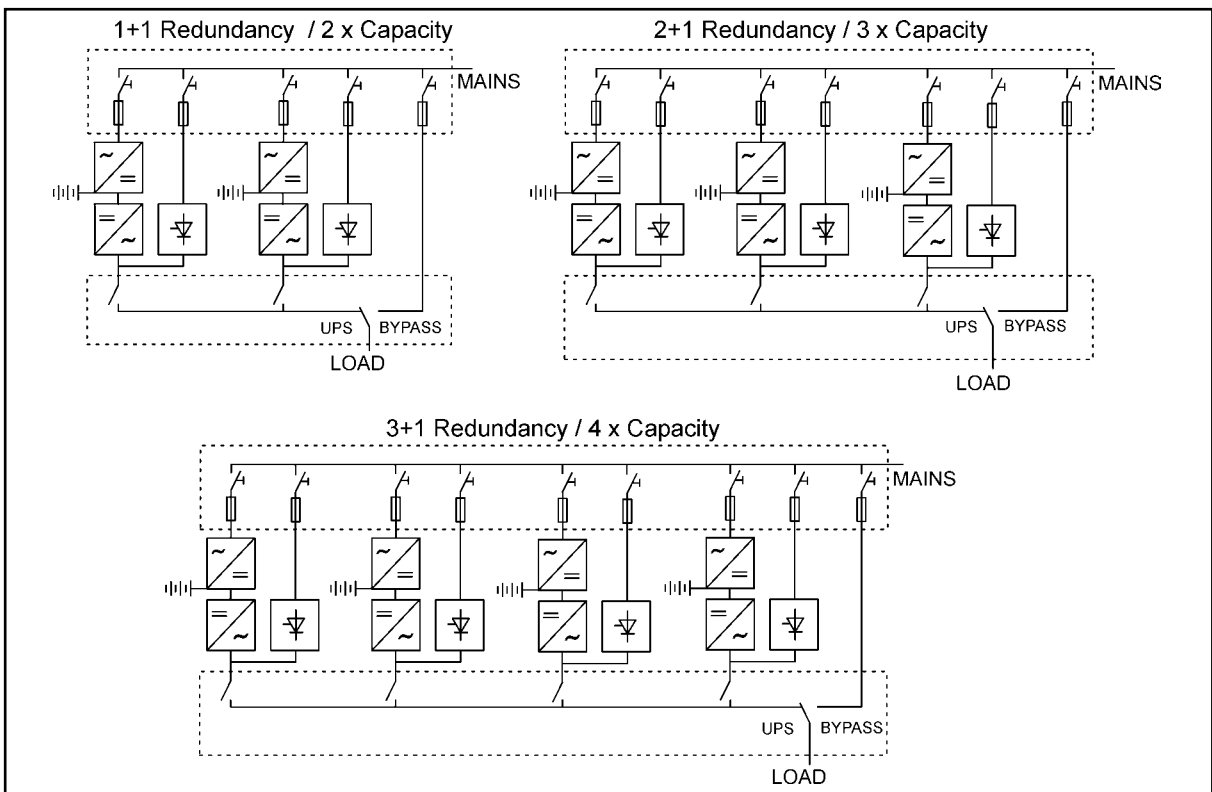
# 10. Parallel systems

## Overview

Parallel UPS configurations are recognised as either redundancy or capacity systems. The redundancy system is used to improve the system reliability with N+1 redundant UPS module. The capacity system for its part provides the maximum output power without focusing to the highest system reliability.

A parameter selection is used to switch between the redundancy and capacity modes. It is important to remember that the mode is affecting to the output power rating and overall system reliability.

UPS modules of the parallel system share equally the load with Hot Sync™ technology. The parallel outputs can be combined in a System Parallel Module or cabinet. It is the system component containing the obligatory service switches. Customer's low-voltage distribution panel can also be used instead of the System Parallel Module. In the redundancy system, service switches enable the maintenance or service on an UPS module. In the capacity system, one needs to have a common system bypass switch to do the maintenance or service without safety hazards.



**Figure 19** Parallel configurations with UPS modules.

Field upgrading can be used to extend existing capacity/redundancy systems with UPS modules. The upgrading must be carried out by service personnel from the manufacturer or from an agent authorised by the manufacturer.

## SPM cabinets

The system parallel modules (SPM), provided by UPS manufacturer, have input connections for two or four parallel UPS modules and make-before-brake type of system bypass switch.

Part nro	Type	Description
1025475	SPM-30-2	Wall-mounted SPM cabinet for 1-2 x UPS 20-30 kVA modules
1025476	SPM-60-2	Wall-mounted SPM cabinet for 1-2 x UPS 40-60 kVA modules
1025831	SPM-30-4	Floor-standing SPM cabinet for 1-4 x UPS 20-30 kVA modules
1025832	SPM40-4	Floor-standing SPM canibet for 1-4 x UPS 40 kVA modules

**Table 9** System Parallel Module (SPM) for redundant & capacity systems

SPM tie cabinets provide the UPS connection terminals for the shared load bus. These cabinets also enable the make-before-break transfer of the load to the system bypass. This can be used for service or test purposes.

The available SPM modules have the following maximum power ratings:

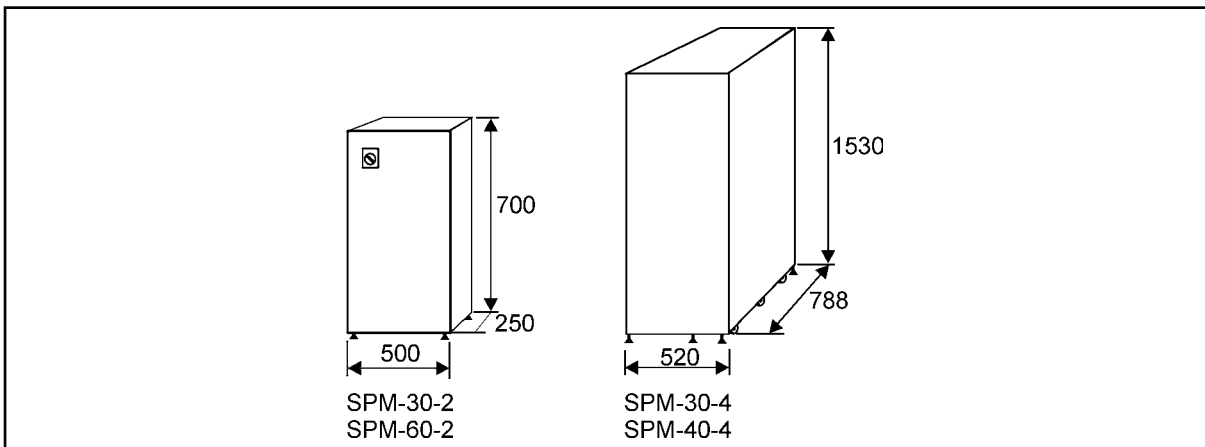
Type	UPS rating	Bypass rating	System voltage
SPM-30-2	1-2 pcs x 30 kVA	60 kVA	400/230 V, 50 or 60 Hz
SPM-60-2	1-2 pcs x 60 kVA	120 kVA	400/230 V, 50 or 60 Hz
SPM-30-4	1-4 pcs x 30 kVA	120 kVA	400/230 V, 50 or 60 Hz
SPM-40-4	1-4 pcs x 40 kVA	160 kVA	400/230 V, 50 or 60 Hz

Input terminals have a five-wire connection (L1, L2, L3, N, and PE). Power cables with copper conductors should be used to fit the terminals. The wiring shall be done according to the wiring diagram. The terminals and cable routing is shown it the figure below.

Auxiliary contact information of the system bypass switch enables a safe transfer of the load. Pay attention that the signal cable of the bypass switch aux. contact is wired correctly to the UPS modules: the polarity of the signal must be the same for all parallel connected UPS modules because the signal sensing is done against the ground.

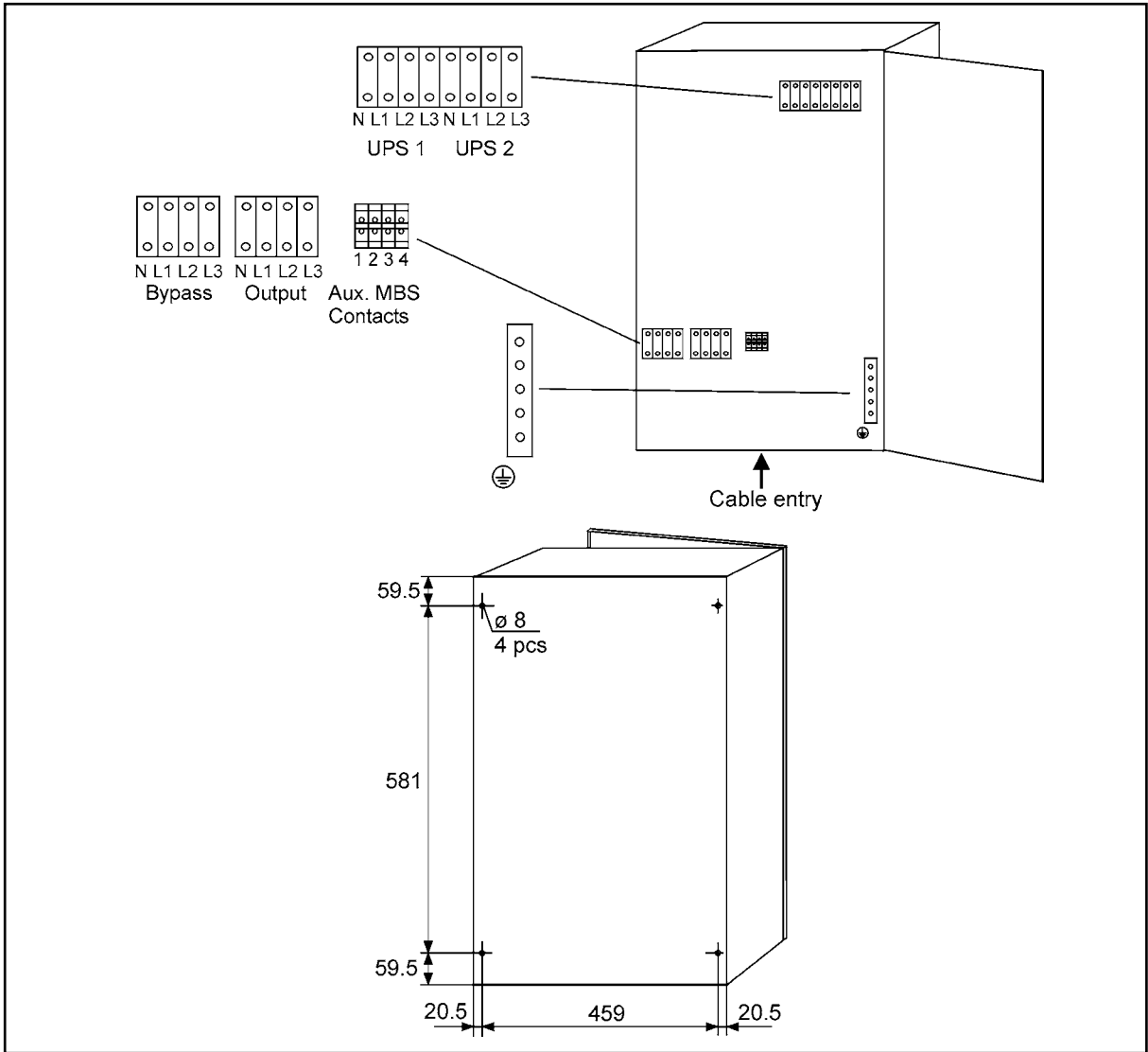
### Notice!

UPS modules should get a minimum of 10 ms leading closed-contact signal when the system bypass switch is turned from UPS to BYPASS position.

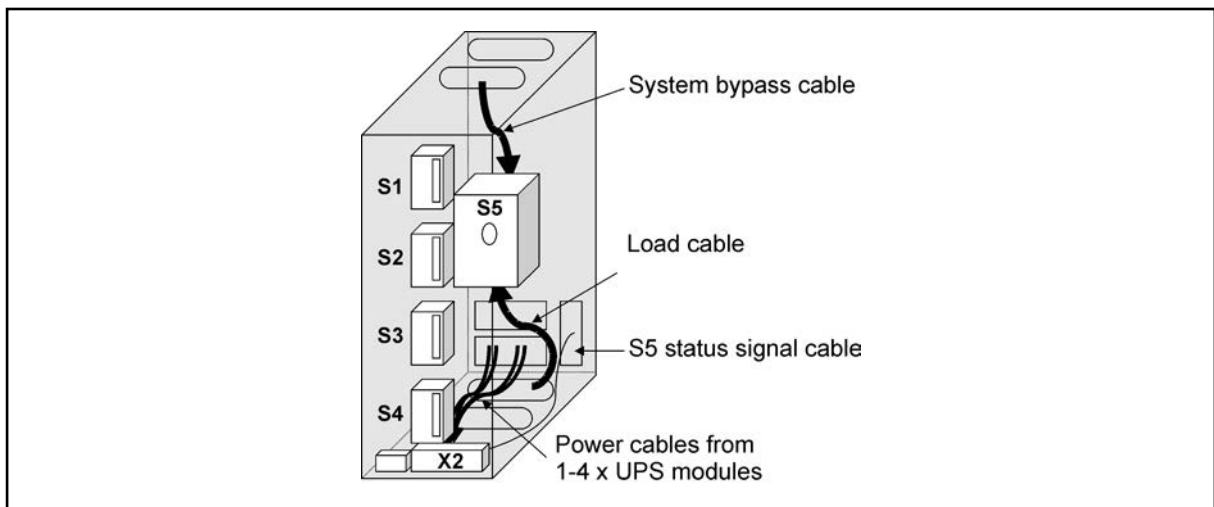


**Figure 20** Dimensions of the SPM-30-2 and SPM-60-2, SPM-30-4 and SPM-40-4

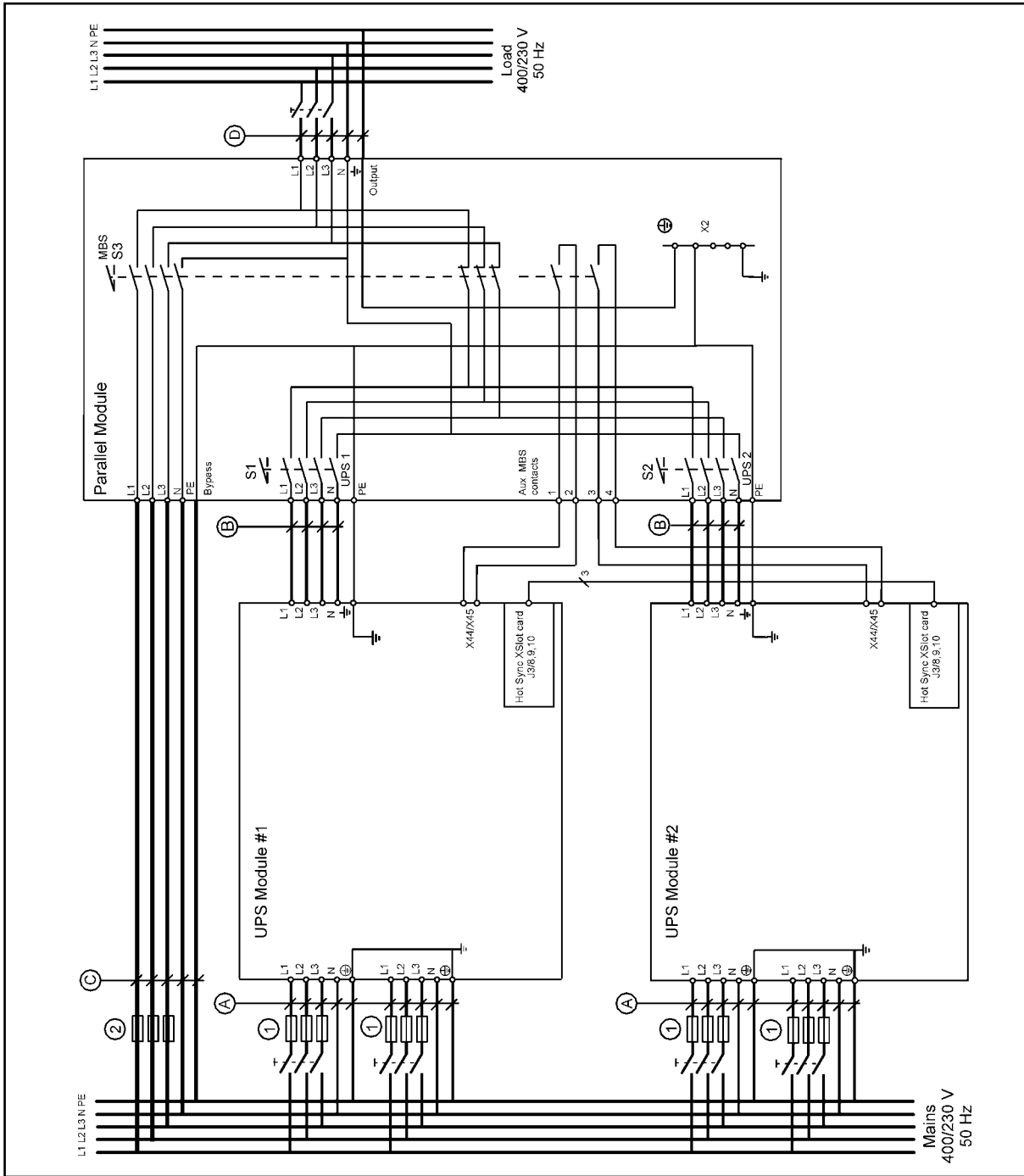




**Figure 21** Cable routing and mounting holes



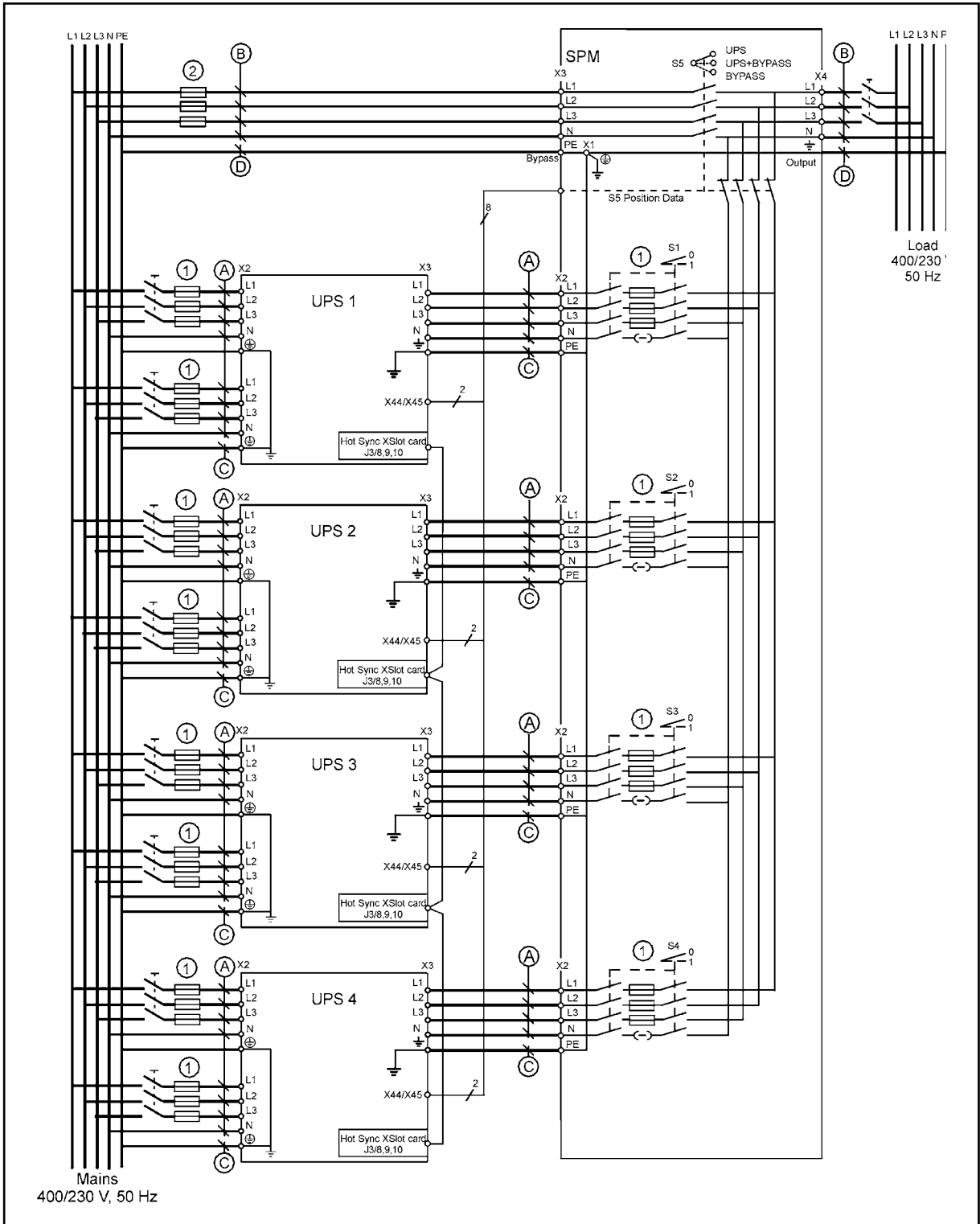
**Figure 22** Cable routing of SPM-30-4 and SPM-40-4 cabinets



**Figure 23** Wiring diagram with SPM-30-2 and SPM-60-2

Power	Fuse 1	Fuse 2*	Cable A/B	Cable C/D
20 kVA	35 A	63 A	10 mm <sup>2</sup>	16 mm <sup>2</sup>
30 kVA	50 A	100 A	10 mm <sup>2</sup>	35 mm <sup>2</sup>
40 kVA	80 A	125 A	25 mm <sup>2</sup>	50 mm <sup>2</sup>
60 kVA	100 A	200 A	35 mm <sup>2</sup>	95 mm <sup>2</sup>


**Table 10** Recommended cables and fuses for the wiring diagram  
 (\*These fuses are sized for capacity systems)



**Figure 24** Wiring diagram with SPM-30-4 and SPM-40-4

UPS module	Cable A	Cable C	Fuse 1
20 kVA	16 mm <sup>2</sup>	16 mm <sup>2</sup>	50 A
30 kVA	16 mm <sup>2</sup>	16 mm <sup>2</sup>	50 A
40 kVA	25 mm <sup>2</sup>	16 mm <sup>2</sup>	80 A
SPM module	Cable B	Cable D	Fuse 2
20 kVA	16 mm <sup>2</sup>	16 mm <sup>2</sup>	50 A
30 kVA	16 mm <sup>2</sup>	16 mm <sup>2</sup>	50 A
40 kVA	16 mm <sup>2</sup>	16 mm <sup>2</sup>	63 A
50 kVA	25 mm <sup>2</sup>	16 mm <sup>2</sup>	80 A
60 kVA	35 mm <sup>2</sup>	16 mm <sup>2</sup>	100 A
80 kVA	50 mm <sup>2</sup>	25 mm <sup>2</sup>	125 A
90 kVA	70 mm <sup>2</sup>	35 mm <sup>2</sup>	160 A
100 kVA	95 mm <sup>2</sup>	50 mm <sup>2</sup>	200 A
120 kVA	95 mm <sup>2</sup>	50 mm <sup>2</sup>	200 A
150 kVA	120 mm <sup>2</sup>	70 mm <sup>2</sup>	250 A
160 kVA	150 mm <sup>2</sup>	95 mm <sup>2</sup>	250 A

**Table 11** Recommended cables and fuses for the wiring diagram



**Note!**

**Protection fuses need to be used for load cabling if manufacturers SPM (or similar) not used.**

Required parallel system wiring length should be in accordance with the following rule, as referenced to the diagram below to ensure approximately equal current sharing when in static bypass mode (see figure below):

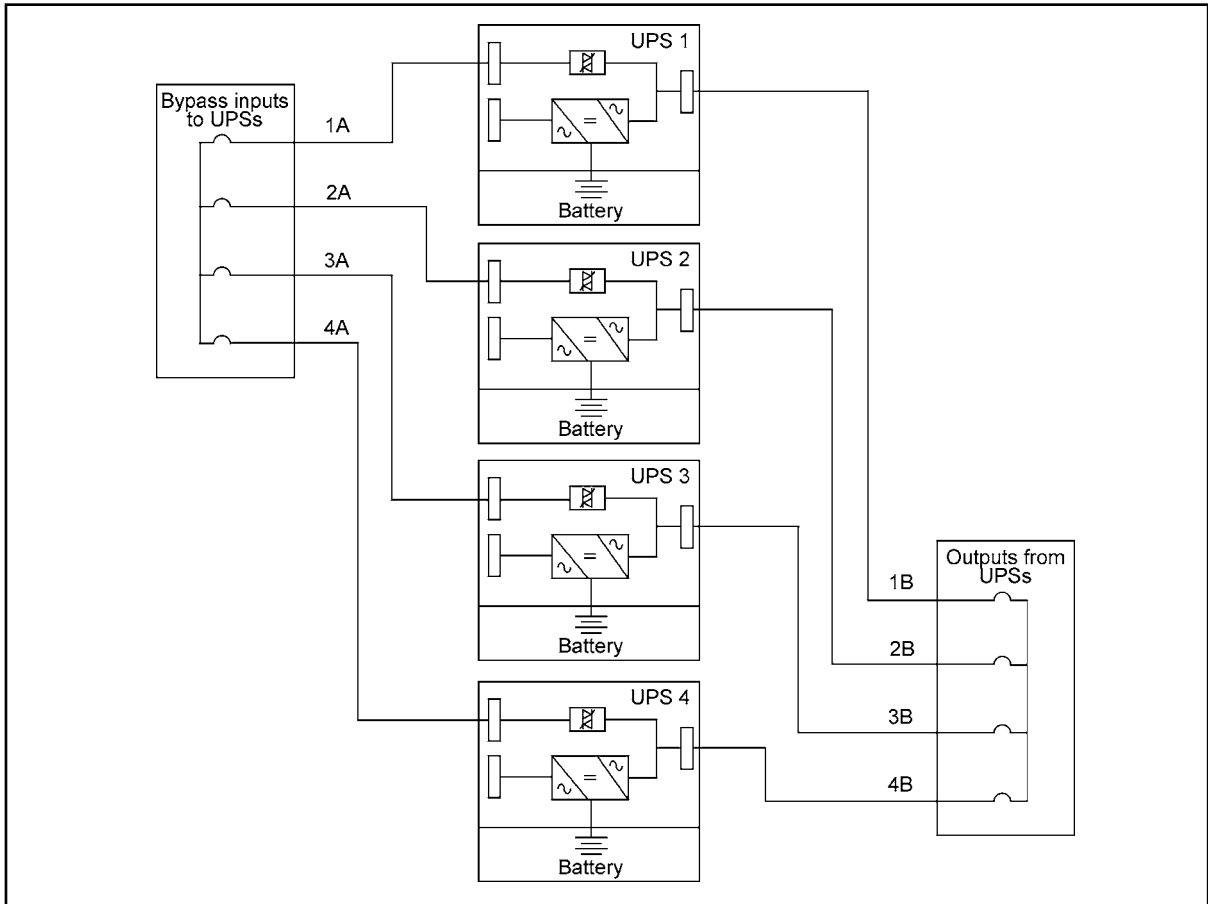
$$\text{Total length of } 1A + 1B = \text{Total length of } 2A + 2B$$

$$= \text{Total length of } 3A + 3B$$

$$= \text{Total length of } 4A + 4B$$

This rule has a tolerance of approximately  $\pm 10\%$  for the combined input and output wire lengths. If installing only two UPS modules (redundant), this requirement is no longer required as each UPS is capable of supporting the full bypass requirement. However, this would preclude future expansion.

The recommended length of B cables is 2 m or more.



**Figure 25** Bypass wiring diagram and cable length notes

## Aux. MBS contacts

Position data connection between SPM and UPS should also be done before taking system in operation. Follow the procedure below to build up position data connection:

1. Remove the door from the UPS.
2. Connect the cables in UPS's programmable input terminal X44 or X45.
3. Connect communication cables to terminals 1 and 2 for UPS Module #1 and to terminals 3 and 4 for UPS Module #2 in the SPM.



**Note!**

**Signal input cables need to be connected to all UPS when used.**

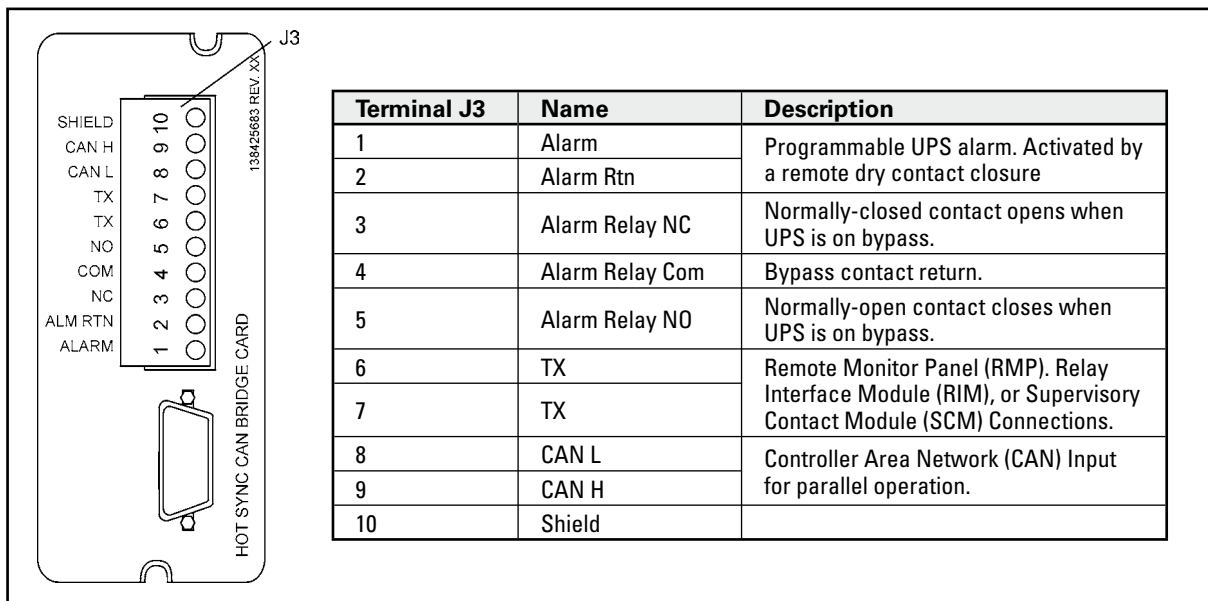
Before proceeding see the Start-up procedure.

4. Start the UPS(s) if not already started.
5. Push any key of the control panel of the UPS to enable the functions on the LCD screen

6. First select "SETTINGS", then "USER SETTINGS" and finally "SIGNAL INPUT" from LCD menu.
7. Select "INPUT 1" (X44) or "INPUT 2" (X45).
8. Browse the menu and select "FORCE BYPASS".
9. Finally check that all the connections have been made correctly and test the functioning of the bypass switch. Check also from the UPS that it goes to bypass mode.

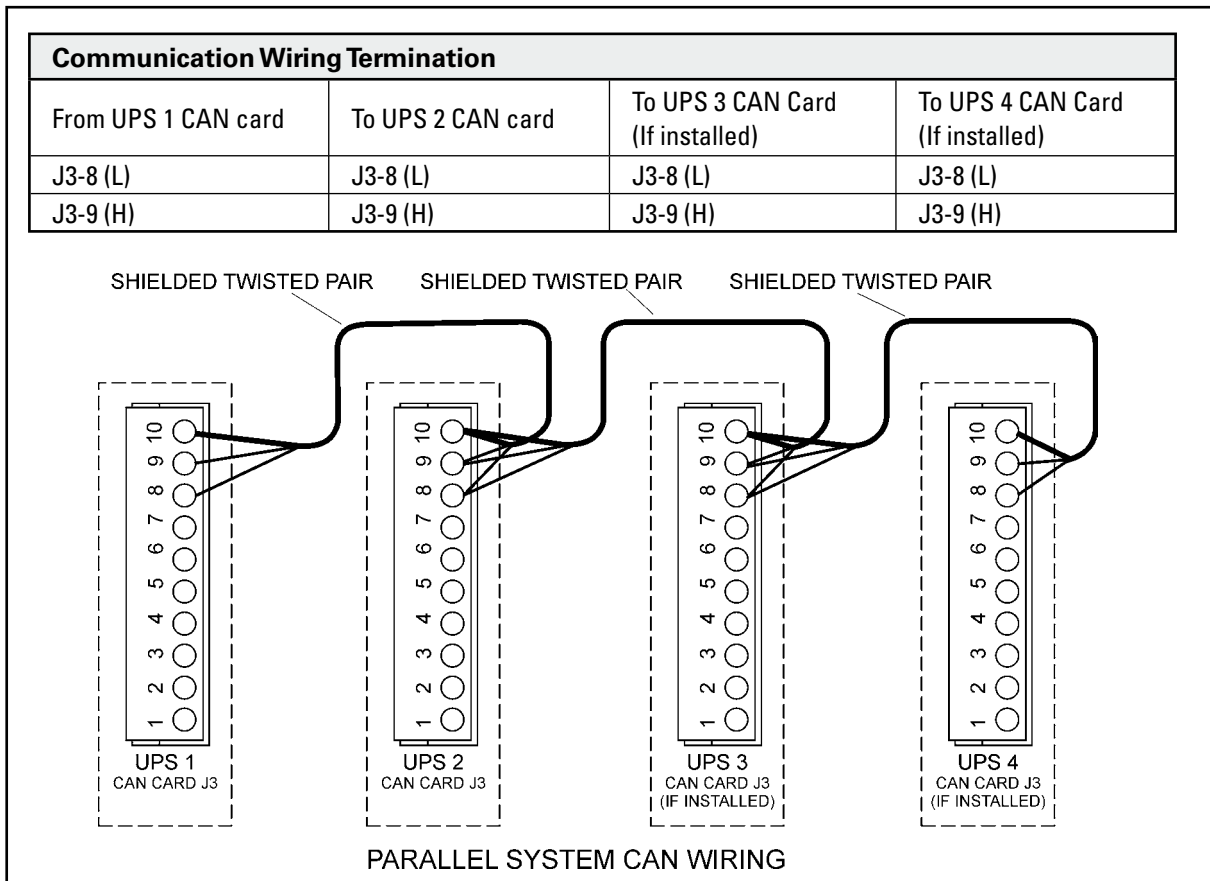
## XSlot Hot Sync card: installing and wiring

To enable parallel operation all the UPSs in the system need the XSlot Hot Sync card (see Figure below) installed into an open XSlot on the front of the UPS (see chapter XSlot communication).



**Figure 26** XSlot Hot Sync card and terminal interface

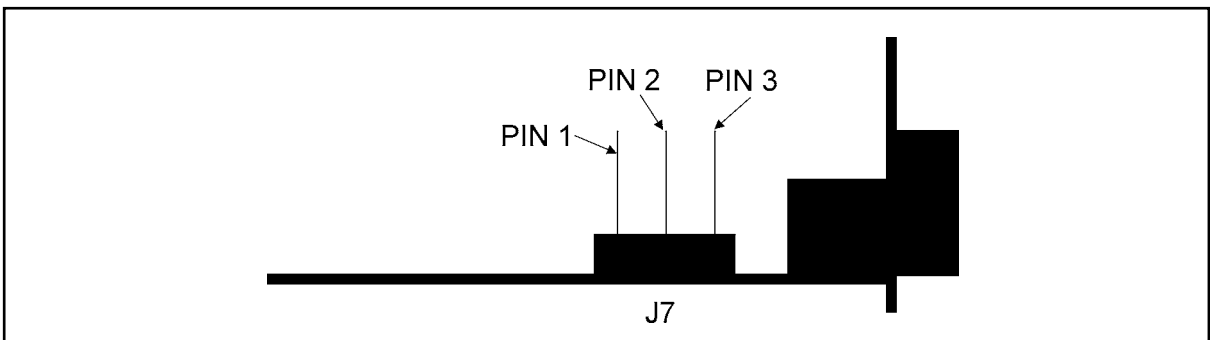
The Hot Sync communication wiring procedure should be done with shielded twisted pair (STP) as presented in the figure below. The maximum length of the cable is 40 m with shield connected to the terminal pin 10 from end of the both cables. Pay attention that you don't mix the polarity among the UPS modules.



**Figure 27** Communication cabling wiring

**⚠ Note!**

**XSlot Hot Sync card has built-in termination resistor enabled by a jumper J7. The default jumper setting without termination resistor is J7: Pin 2-3. The first and the last UPS modules should have the termination resistor enabled by connecting Pins 1 and 2 with the jumper J7.**



**Figure 28** XSlot Hot Sync card and jumper settings: Resistor ON: PIN 1 and PIN 2 connected, No resistor: PIN 2 and PIN 3 connected (default setting).

# Start-up and operation

## Start-up procedure



### Note!

**Before start-up make sure that UPS installations have been carried out correctly and ground connections of both UPS units and parallel module have been connected. Check also that the XSlot HotSync cards are installed correctly an the communication line between UPSs is connected according to figure Communication cabling wiring.**

When installation is completed correctly the start procedure can be started.



### Note!

**If some settings are changed from User settings the same changes need to be done separately to all of the UPSs in the system.**

Carry out the following procedure to **each UPS** you want to have in system.

1. Turn the battery and input circuit breakers to ON position.
2. UPS will enter a stand-by mode and starts to charge batteries with a cooling fan operational. Output is without the voltage in the stand-by mode.
3. Push any key of the control panel to enable the functions of the LCD screen.
4. Select unit number in parallel system: Unit #1, Unit #2, Unit #3 or Unit #4. Select: SETTINGS -> USER SETTINGS -> PARALLEL OPERATION SETTINGS -> PARALLEL UNIT NUMBER
5. Select minimum units to support load: 0-4. Select: SETTINGS -> USER SETTINGS -> PARALLEL OPERATION SETTINGS -> MINIMUM UNITSTO SUPPORT LOAD  
Do the following item (item 6) only for one UPS, which belongs to the system.
6. Return to main menu and select TURN SYSTEM ON.

All the UPSs shall check their internal functions, synchronize to bypass and start to supply the load.



### Note

**After the first start the load sharing of the system needs to be calibrated. Before starting the calibration the system needs to support some load.**

7. Select: SETTINGS -> USER SETTINGS -> PARALLEL OPERATION SETTINGS -> START AUTO CALIBRATION



## Operating system bypass switch

The system bypass switch is used to bypass the parallel system during maintenance or servicing. Maintenance bypass switch is located on the front panel of the optional SPM cabinet. using the switch does not cause any break in the output voltage, if the input voltage and frequency are accepted and the system is synchronised to the input mains.

### SPM-30-2 and SPM-60-2

The parallel module includes a mechanical bypass switch S3 (Make-Before-Break type) and two maintenance switches S1 and S2 for disconnecting the outputs of UPS modules during maintenance or service.

The maintenance bypass switch has the following positions:

- 'I' or 'UPS' normal position, the load is supplied from the UPS modules.
- 'II' or 'BYPASS' position, the UPS modules are bypassed and the critical load is supplied from the system bypass power line.

### SPM-30-4 and SPM-40-4

The parallel module includes a mechanical bypass switch S5 (Make-Before-Break type) and four maintenance switches S1, S2, S3, and S4 for disconnecting the outputs of UPS modules during maintenance or service.

The maintenance bypass switch has the following positions:

'I' or 'UPS' normal position, the load is supplied from the UPS modules.

'I'+ 'II' or 'UPS+BYPASS' position, the load is supplied from UPS modules (internal bypass mode) and the system bypass in parallel.

'II' or 'BYPASS' position, the UPS modules are bypassed and the critical load is supplied from the system bypass power line.

If the system bypass switch needs to be used it is recommended to check that the bypass input power is connected and present in the SPM cabinet. The switch is used only on rare occasions and the procedure is following:

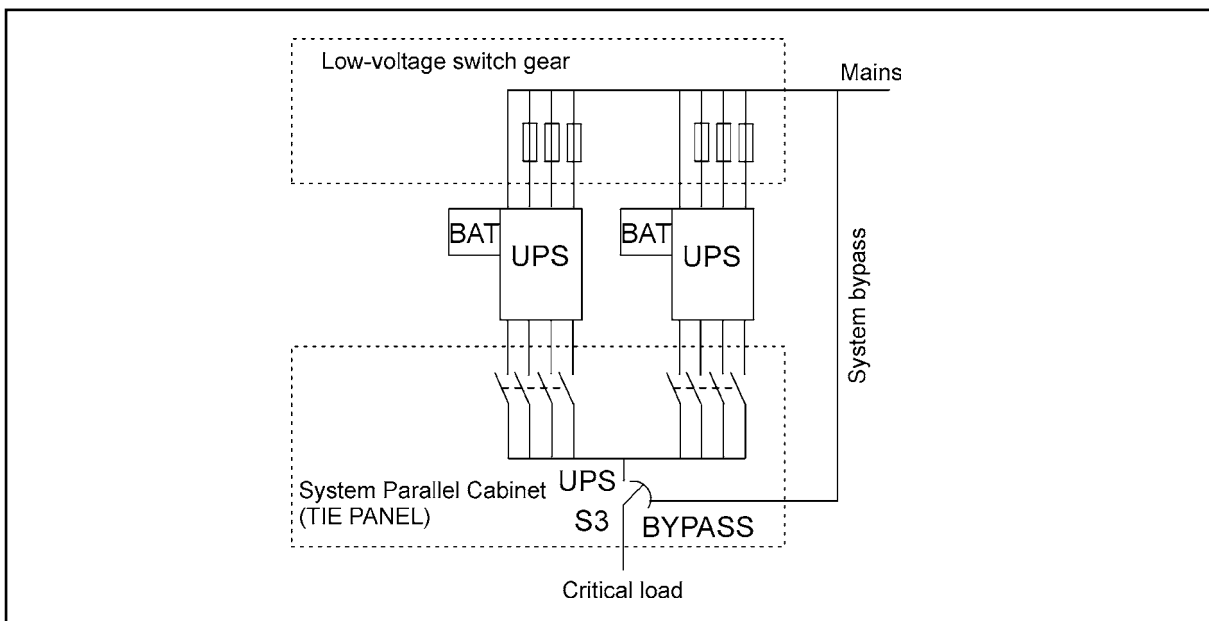
1. Check that the 'bypass not available' alarm is not active in the UPS modules. (Press menu button, choose UPS status display).
2. Use LCD to turn UPS unit(s) on internal bypass mode.  
Select: CONTROL -> GOTO BYPASS MODE
3. Verify the transfer before proceeding the next step.
4. Turn the maintenance bypass switch to BYPASS position.



**The use of the maintenance bypass switch will cause a break in the output voltage if the input voltage or frequency is not correct and the UPS system is not synchronised to mains.**

Following procedure does returning to normal online mode:

1. Make sure UPS modules have been started according to chapter 'Start-up procedure',.
2. Check that UPS ON and BYPASS LED's are lit in the front panel.
3. Make sure service switches S1...S2/S4 in the SPM are in 'ON' position.
4. Turn the system bypass switch S3/S5 to 'UPS' position.
5. Use LCD to turn UPS unit(s) to normal mode.  
Select: CONTROL -> GOTO NORMAL MODE.
6. Verify the transfer by checking that the yellow bypass LED is turned off.



**Figure 29.** System bypass switch of the optional SPM

## Shut-down procedure

While system is running and UPSs are supporting load, there are two different ways to perform a shutdown. The user can select either to shutdown the whole system or only one UPS.

1. Select TURN SYSTEM OFF from the main menu → All the UPSs in the system will go to stand-by mode.
2. Select TURN UPS OFF → Only the selected UPS will go stand-by mode.

Either 1 or 2 is selected ↓ button needs to be pressed for 5 seconds.

When UPS is in stand-by mode it still charges its batteries and uses cooling fans. Stand-by mode possible a fast restart. If some UPS or all the UPSs in the system need to be shutdown completely, proceed to item 3.

3. Select TURN UPS OFF and press and hold ↵ button for 5 seconds. There shall be an indication sound during the hold.
4. UPS shall do a shutdown routine.
5. Turn the battery and input circuit breakers to off position to finalise the shutdown procedure.

### Local tie panel solutions

The internal wiring diagrams of tie cabinets can be used as a reference when designing local tie panels.


Parallel UPS configurations require a tie panel at the system output. It must facilitate service switches for each UPS module output. The system bypass switch is optional but helps when doing the maintenance for the whole parallel UPS system. It's recommend to source cabinet, cables, busbars, terminals, fuses, switches and breaker components from the local market.

## 11. Recycling the used UPS or batteries


Before scrapping UPS or its battery cabinet, the battery bank must be removed. Local requirements must be followed in battery recycling or discard. The removal of batteries is allowed only by authorised service personnel due to high energy and voltage.

Do not discard waste electrical or electronic equipment in the trash. For proper disposal, contact your local collecting/recycling/reuse or hazardous waste center and follow the local legislation.


These symbols indicate on a product:



Use proper local collecting centers meeting local legislation when handling waste of electrical and electronic equipment.

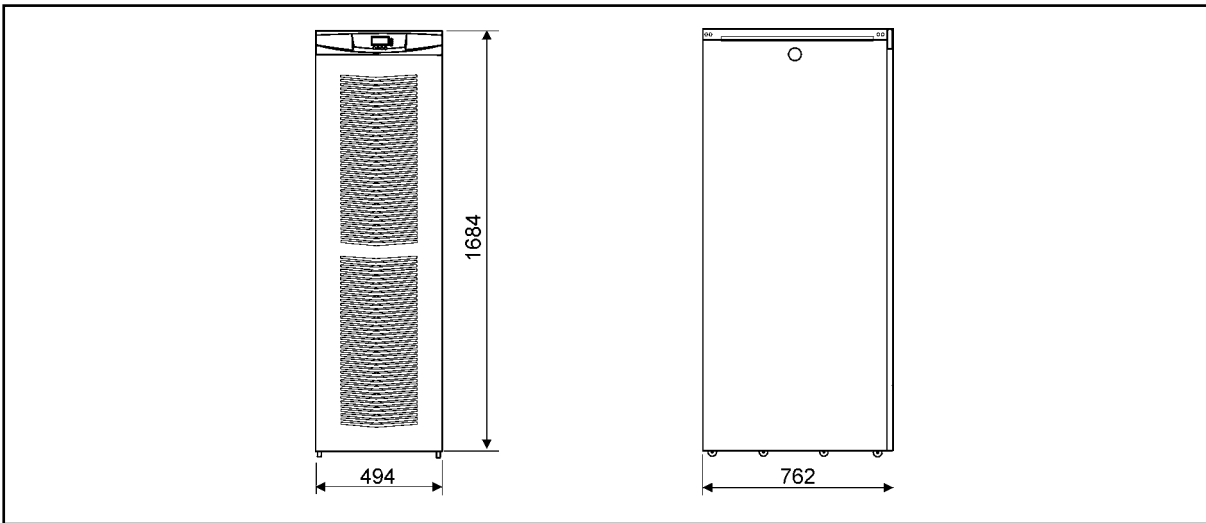


**WARNING!**

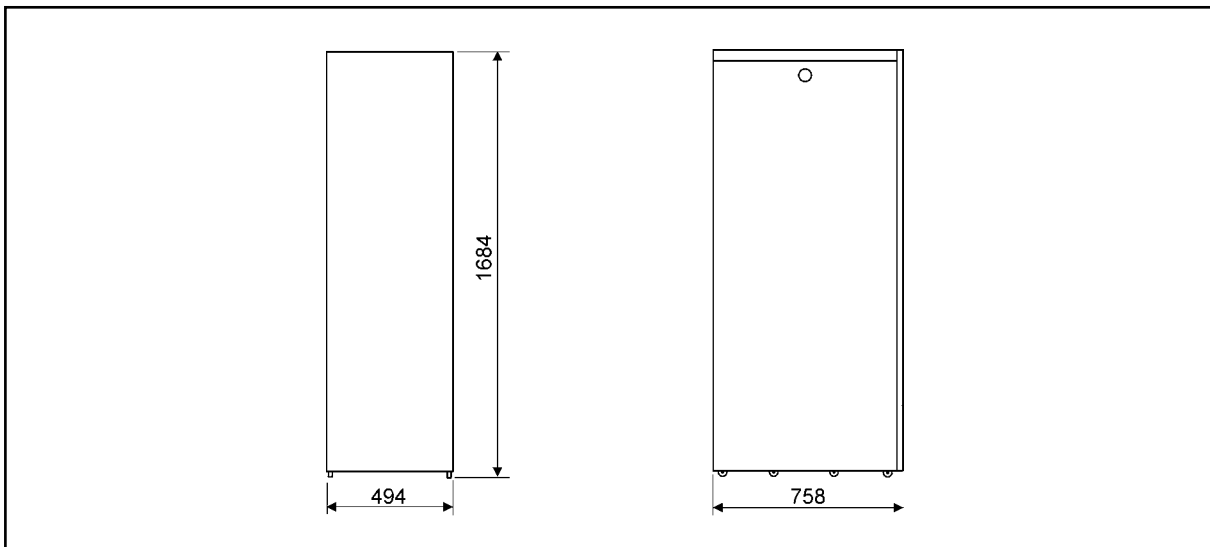


**HAZARDOUS MATERIALS. Batteries may contain HIGH VOLTAGES, and CAUSTIC, TOXIC and FLAMMABLE substances. Batteries can injure or kill people and damage equipment if used improperly. DO NOT DISCARD unwanted batteries or battery material in the public waste disposal system. Follow ALL applicable, local regulations for storage, handling and disposal of batteries and battery materials.**

## 12. Dimensional drawings



**Figure 30** Dimensions of the UPS cabinet.



**Figure 31** Dimensions of the External Battery Cabinet

# 13. Technical data

## Standards

UPS	20 kVA	30 kVA	40 kVA
Safety	IEC 62040-1-1, EN 62040-1-1 and EN 60950		
EMC	EN 50091-2		
Product	IEC 62040-3 and EN 62040-3		

## Environment

UPS	20 kVA	30 kVA	40 kVA
Amb. temperature	0 to +40°C (electronics), 15 to +25°C (batteries)		
Relative humidity	0 to 95%, no condensation allowed		
Altitude	<1000 m above sea level		
Vibration	IEC 68-2-6; max. 0.3 mm (2 to 9 Hz), max. 1 m/s <sup>2</sup> (9 to 200 Hz) sinusoidal		

## Maintenance configuration

UPS	20 kVA	30 kVA	40 kVA
Dimensions			
- Width	494 mm		
- Depth	762 mm		
- Height	1684 mm		
Weight			
- no battery	200 kg		217 kg
- 36 battery	300 kg		317 kg
- 72 battery	400 kg		417 kg
- 108 battery	500 kg		517 kg
- 144 battery	600 kg		617 kg
Colour	RAL 9005 black		

## Characteristics

Powerware 9355	20 kVA	30 kVA	40 kVA
Efficiency			
- nominal load	Up to 93%	Up to 93%	Up to 93%
Heat losses	<1600 W	<1900 W	<2550 W
Backup time	5 min (36 bat 9Ah) 13 min (72 bat 9Ah)	- 7 min (72 bat 9Ah)	- -
- load pf 0.7	22 min (108 bat 9Ah)	13 min (108 bat 9Ah)	8 min (108 bat 9 Ah)
- temperature 25°C	31 min (144 bat 9Ah)	20 min (144 bat 9Ah)	12 min (144 bat 9 Ah)
Noise (ISO 7779)	50 - 53 dB(A) depending on the load	50 - 53 dB(A) depending on the load	50 - 53 dB(A) depending on the load

## AC input

Powerware 9355	20 kVA	30 kVA	40 kVA
Rectifier input	3 phases + N		
Bypass input	3 phases + N		
Voltage (L-N)	192 to 276 Volts without using battery		
Frequency	45 to 65 Hz		
Power factor	0.99		
Input distortion	< 5% THD(I)		
Rated input current	28.1 A	42.1 A	56.1 A

## DC circuit

Powerware 9355	20 kVA	30 kVA	40 kVA
Management	Advanced Battery Management		
Nominal voltage	432 Volts		
Battery qty	36 / string		
Float voltage	2.30 VPC		
Battery type	VRLA 12 Volts		
Cut off voltage	1.75 VPC		
Battery charging	6 A, user selectable		

## AC output

Powerware 9355	20 kVA	30 kVA	40 kVA
Active power	18 kW	27 kW	36 kW
Number of phases	3-phases + N		
Frequency	50 Hz or 60 Hz, user selectable		
Voltage (L-N)	220, 230 or 240 Volts, user selectable		
Short circuit capability	110 A, < 300 ms		145 A, < 300 ms
Overload capability	10 min > 100 – 110% load 1 min > 110 – 125% load 5 sec > 125 – 150% load 300 ms > 150% load		
Overload capability (mains available)	60 min > 100 – 110% load 10 min > 110 – 125% load 1 min > 125 – 150% load		

## 14. Warranty

The product is warranted against defects in design, materials and workmanship for a period of twelve (12) months from its original date of purchase. The local office or distributor may grant a warranty period different to the above and refer to local terms of liability as defined in the supply contract.

The UPS manufacturer is not responsible for

- Any costs resulting from a failure if the installation, commissioning, repair, alternation, or ambient conditions of the equipment do not fulfil the requirements specified in the documentation delivered with the unit and other relevant documentation.
- Equipment subjected to misuse, negligence or accident
- Equipment comprised of materials provided or designs stipulated by the purchaser.

Under no circumstances shall the manufacturer, its suppliers or subcontractors be liable for special, indirect, incidental or consequential damages, losses or penalties.

The technical data, information and specifications are valid at the time of printing. The UPS manufacturer reserves the right to modifications without prior notice.

