

User's Guide

IMPORTANT SAFETY INSTRUCTIONS

SAVE THESE INSTRUCTIONS

This manual contains important instructions that you should follow during installation and maintenance of the UPS and batteries. Please read all instructions before operating the equipment and save this manual for future reference.

This is a product for commercial and industrial application in the second environment. Installation restrictions or additional measures may be needed to prevent disturbances.

**© 2013 Eaton Corporation
All Rights Reserved**

The contents of this manual are the copyright of the publisher and may not be reproduced (even extracts) without the written approval of Eaton Corporation. Every care has been taken to ensure the accuracy of the information contained in this manual, but no liability can be accepted for any errors or omission. The right to make design modifications is reserved.

Contents

1 Safety instructions.....	1
1.1 Audience.....	1
1.2 CE marking.....	1
1.3 User precautions.....	1
1.4 Environment.....	2
1.5 Inquiries.....	2
2 Introduction.....	3
2.1 System description.....	3
2.2 Active-Front technology.....	4
2.3 Advanced Battery Management (ABM) [™]	5
2.4 Hot Sync [®] technology.....	5
2.5 DNV Type approval and ABS product design assessment.....	6
2.6 Basic system configuration.....	6
3 Mechanical installation.....	7
3.1 Delivery check.....	7
3.2 Unpacking and visual inspection.....	7
4 Planning before installation.....	9
5 Cabinet installation.....	11
5.1 Maintenance bypass switch.....	11
5.2 Transformer option.....	12
5.3 External battery cabinet option.....	13
5.4 Battery racks.....	13
6 Electrical installation.....	14
6.1 Power cables and protective fuses.....	15
6.2 Wiring procedure.....	15
6.2.1 UPS models without an internal transformer.....	16
6.2.2 UPS models with an internal input transformer.....	17
6.2.3 UPS models with an internal output transformer.....	19
6.3 External Battery Cabinet (EBC) installation procedure.....	37
7 Software and connectivity.....	40
7.1 Communication cables.....	40
7.2 Connection to the standard RS-232 port (X53).....	41
7.2.1 LanSafe software.....	41
7.3 External control connections.....	42
7.3.1 Emergency Power Off (EPO).....	42
7.3.2 Relay outputs.....	43
7.3.3 Programmable signal inputs.....	43
7.3.4 EPO relay (option).....	44
7.3.5 Earth fault monitor (option).....	45
7.4 XSlot communication (option).....	45
7.4.1 Web/SNMP Module (optional).....	46
7.4.2 AS400 Relay Module (optional).....	47
7.4.3 Single Serial Port Module (optional).....	47
7.4.4 Modus/Jbus Module (optional).....	48
8 User operations.....	49
8.1 Display functions.....	49
8.2 User settings.....	50
8.2.1 Configuring user settings.....	53
8.2.2 Changing language.....	53
8.2.3 Changing charging current.....	53
8.2.4 Using relay outputs.....	54
8.3 Normal start-up.....	54
8.4 Battery start-up.....	56

8.5 Start-up after EPO.....	56
8.6 Shutdown.....	56
9 Maintenance.....	57
9.1 Regular service/intervals.....	57
9.1.1 Batteries.....	58
9.1.2 Cooling fan.....	58
9.2 LED indicators.....	58
9.3 Maintenance bypass switch (MBS) operation.....	59
9.3.1 Internal maintenance bypass switch operation.....	59
9.3.1.1 Turn UPS from normal mode to mechanical bypass.....	60
9.3.1.2 Turn UPS from mechanical bypass to normal mode.....	61
9.3.2 Maintenance bypass switch operation.....	62
9.3.2.1 Turn UPS from normal mode to mechanical bypass.....	63
9.3.2.2 Turn UPS from mechanical bypass to normal mode.....	64
10 Parallel systems.....	66
10.1 Overview.....	66
10.2 Tie cabinets.....	67
10.3 XSlot Hot Sync card: installing and wiring.....	73
10.4 Parallel operations.....	76
11 Recycling the used UPS or batteries.....	78
12 Dimensional drawings.....	79
13 Wiring diagrams for internal transformer.....	85
14 Technical data.....	88
15 Warranty.....	92

List of Figures

Figure 2-1: Marine UPS units 8-15 kVA type approved models.....	4
Figure 3-1: Type designation label.....	8
Figure 4-1: Marine UPS units 8-15 kVA.....	9
Figure 5-1: Marine UPS unit with internal input transformer.....	11
Figure 5-2: UPS unit with battery module(s) and the rear mounted mechanical bypass switch.....	12
Figure 5-3: UPS unit with the factory installed isolation transformer.....	13
Figure 6-1: The location of the power terminals for UPS unit without an internal transformer.....	16
Figure 6-2: The location of the power terminals for UPS unit with an internal input transformer.....	17
Figure 6-3: Cable connections into a transformer section.....	18
Figure 6-4: The location of the power terminals for UPS unit with an internal output transformer.....	19
Figure 6-5: Wiring diagram of 9155 N-model (3-phase in / 1-phase out). For cable and fuse sizes, see the Table 6-1.....	21
Figure 6-6: Wiring diagram of type approved 9155 N-model (3-phase in / 1-phase out). For cable and fuse sizes, see the Table 6-1.....	22
Figure 6-7: Wiring diagram of 9155 NT-model with internal MBS (3-phase in / 1-phase out). For cable and fuse sizes, see the Table 6-2.....	24
Figure 6-8: Wiring diagram of type approved 9155 NT-model with internal MBS (3-phase in / 1-phase out). For cable and fuse sizes, see the Table 6-2.....	25
Figure 6-9: Wiring diagram of 9155 S-model (1-phase in / 1-phase out). For cable and fuse sizes, see the Table 6-3.....	27
Figure 6-10: Wiring diagram of type approved 9155 S-model (1-phase in / 1-phase out). For cable and fuse sizes, see the Table 6-3.....	28
Figure 6-11: Wiring diagram of 9155 ST-model with internal MBS (1-phase in / 1-phase out). For cable and fuse sizes, see the Table 6-3.....	29
Figure 6-12: Wiring diagram of type approved 9155 ST-model with internal MBS (1-phase in / 1-phase out). For cable and fuse sizes, see the Table 6-3.....	30
Figure 6-13: Wiring diagram of 9355 N-model (3-phase in / 3-phase out). For cable and fuse sizes, see the Table 6-4.....	32
Figure 6-14: Wiring diagram of type approved 9355 N-model (3-phase in / 3-phase out). For cable and fuse sizes, see the Table 6-4.....	33
Figure 6-15: Wiring diagram of 9355 NT-model (3-phase in / 3-phase out). For cable and fuse sizes, see the Table 6-4.....	34
Figure 6-16: Wiring diagram of type approved 9355 NT-model (3-phase in / 3-phase out). For cable and fuse sizes, see the Table 6-4.....	35
Figure 6-17: Connections of the UPS unit and External Battery Cabinets.....	37
Figure 6-18: Cable connections of the External Battery Cabinet.....	38
Figure 6-19: To minimise safety risk remove + or - cable from battery string before connecting UPS and EBCs.....	39
Figure 7-1: Location of control cable terminals: Signal inputs (X44 & X45); EPO (NC (X12) & NO (X52)); RS-232 (X53); Relay output (X57).....	40
Figure 7-2: Identification of the interface port pins.....	41
Figure 7-3: External control cable connections to the UPS.....	42
Figure 7-4: EPO relay and the connection diagram.....	44
Figure 7-5: Earth fault monitor and the connection diagrams for 9155 and 9355 models.....	45
Figure 7-6: Location of empty XSlot bays.....	46
Figure 7-7: ConnectUPS-X Web/SNMP Module and Environmental Monitoring Probe.....	47
Figure 7-8: AS400 Relay Module.....	47
Figure 7-9: Modus/Jbus Module.....	48
Figure 9-1: The normal (UPS supplying the load) positions of the MBS switches.....	60
Figure 9-2: The normal positions of the MBS switches.....	60
Figure 9-3: The positions of the MBS switches in the mechanical bypass mode.....	61
Figure 9-4: The normal (UPS supplying the load) positions of the MBS switches.....	63
Figure 9-5: The normal positions of the three MBS switches.....	63
Figure 9-6: The positions of the three MBS switches in the mechanical bypass mode.....	64
Figure 9-7: The normal positions of the MBS switches in the Normal mode.....	65
Figure 10-1: Parallel configurations with UPS modules.....	66
Figure 10-2: Dimensions of the Tie Cabinet.....	67
Figure 10-3: Cable routing of the Tie Cabinet: 1-phase model on the left and 3-phase model on the right.....	68
Figure 10-4: 1-phase Tie Cabinet's wiring diagram with three UPS units.....	68
Figure 10-5: 1-phase Tie Cabinet's wiring diagram with two UPS units and bypass connected.....	69
Figure 10-6: 3-phase Tie Cabinet's wiring diagram with three UPS units.....	70
Figure 10-7: 3-phase Tie Cabinet's wiring diagram with two UPS units and bypass connected.....	71
Figure 10-8: Bypass wiring diagram and cable length notes.....	73
Figure 10-9: XSlot Hot Sync card and terminal interface.....	74
Figure 10-10: Communication cabling wiring.....	75
Figure 10-11: XSlot HotSync card and jumper settings.....	75
Figure 11-1: WEEE symbol.....	78
Figure 11-2: Recycling batteries symbol.....	78
Figure 12-1: Standard and type approved marine UPS models with one bottom battery module.....	79
Figure 12-2: Standard and type approved marine UPS models with two bottom battery modules.....	80
Figure 12-3: Standard and type approved marine UPS models with one bottom transformer module.....	81
Figure 12-4: Standard and type approved marine UPS models with middle battery and bottom transformer module.....	82
Figure 12-5: Standard and type approved marine UPS models with no battery or transformer modules.....	83
Figure 12-6: External battery cabinet models with two and three modules.....	84
Figure 13-1: Internal transformer wirings for 9155 NT model.....	85
Figure 13-2: Internal transformer wirings for 9155 ST model.....	86
Figure 13-3: Internal transformer wirings for 9355 NT model.....	87

List of Tables

Table 4-1: The floor surface must withstand these weights (Standard models).....10

Table 4-2: The floor surface must withstand these weights (TA models)..... 10

Table 6-1: Recommended cable and fuse sizes for 9155 N-model (No transformer)..... 23

Table 6-2: Recommended cable and fuse sizes for 9155 NT-model..... 26

Table 6-3: Recommended cable and fuse sizes for 9155 S model and 9155 ST model.....31

Table 6-4: Recommended cable and fuse sizes for 9355 N-model and 9355 NT-model..... 36

Table 7-1: Typical XSlot configurations for UPS communication.....46

Table 8-1: Menu map for display functions.....49

Table 8-2: User setting in the LCD menu screen..... 51

Table 8-3: Required battery charge currents.....53

Table 9-1: Typical alarms displayed in the LCD screen of the UPS unit.....57

Table 9-2: Routine maintenance intervals recommended by the manufacturer.....57

Table 9-3: Description of the LED indicators..... 58

Table 10-1: Minimum cable and fuse rating for the different parallel system with installation procedure C * (system bypass not allowed)..... 69

Table 10-2: Minimum cable and fuse rating for the different parallel system with installation procedure C * (system bypass not allowed)..... 71

Table 10-3: Description for figure XSlot Hot Sync card and terminal interface.....74

Table 10-4: Communication Wiring Termination..... 75

Table 14-1: Standards..... 88

Table 14-2: Environment..... 88

Table 14-3: Mechanical configuration..... 88

Table 14-4: Characteristics..... 89

Table 14-5: AC input..... 89

Table 14-6: DC circuit..... 90

Table 14-7: AC output..... 91

1 Safety instructions

The UPS operates with mains, battery or bypass power. It contains components that carry high currents and voltages. The properly installed enclosure is earthed and IP22 rated against electrical shock and foreign objects. However, only qualified personal is allowed to install and service the UPS.



WARNING

Operations inside the UPS must be performed by a service engineer from the manufacturer or from an agent authorised by the manufacturer.

Do not ever service inside the UPS when mains power is applied or the UPS is in battery mode. Use the optional mechanical bypass if installed to the system. Remember to open battery breaker. Always ensure by measuring with a multi-meter that no dangerous voltages are present.

.1 Audience

The intended audiences of this manual are people who plan the installation, install, commission, and use or service the UPS. The manual provides guidelines to check delivery, installing and commissioning of the UPS.

The reader is expected to know the fundamentals of electricity, wiring, electrical components and electrical schematic symbols. This manual is written for a global reader.



OTE

Read the manual before operating or working on the UPS.

.2 CE marking

The product has the CE marking in compliance with the following European directives:

- LV Directive (Safety) 72/23/EEC and 93/68/EEC
- EMC Directive 89/336/EEC and 93/68/EEC

Declaration of conformity with UPS harmonised standards and directives EN 62040-1-1 (Safety) and EN 62040-2 (EMC) are available on the web site (www.eaton.com/powerquality).

.3 User precautions

The only user operations permitted are:

- Start up and shut down of the UPS, excluding the commissioning start-up.
- Use of the LCD control panel and Maintenance Bypass Switch (MBS).
- Use of optional connectivity modules and their software.

The user must follow the precautions and only perform the described operations. Any deviations from the instructions could be dangerous to the user or cause accidental load loss.



WARNING

The user is not permitted to open of any screws excluding connectivity plates and the MBS locking plate. Failure to recognise the electrical hazards could prove fatal.

.4 Environment

The UPS must be installed according to the recommendations in this manual. UPS units and battery cabinets are designed for installation in non-hazardous environments. Under no circumstances the UPS or the batteries should be installed in an airtight room, in the presence of flammable gases, or in an environment exceeding the specification.

For battery cabinets, the ventilation of the environment should be designed so that the concentration of hydrogen stays below 4% Lower Explosive Limit (LEL). Designing the ventilation according to EN50242-2 is recommended.

Excessive amount of dust in the operating environment of UPS may cause damage or lead to malfunction. The UPS should be always protected from the outside weather and sunshine. The recommended operating temperature is from +15 to +25 Celsius degrees.

.5 Inquiries

Address any inquiries about the UPS and battery cabinet to the local office or agent authorised by the manufacturer. Please quote the type code and the serial number of the equipment.

2 Introduction

The product described in this manual is an Uninterruptible Power System (UPS) intended for marine applications. It is a true online, continuous duty, double conversion, static state, single- or three-phase system, providing conditioned and uninterruptible AC power to protect the customer's load from all the different power failures.

2.1 System description

The UPS units are used to provide back-up power for safety, propulsion and cruising related systems, protect sensitive IT equipment and prevent loss of valuable electronic information, minimise equipment downtime, and minimise the adverse effect on different equipment due to unexpected power problems.

The UPS system continually monitors incoming electrical power and removes the surges, spikes, sags, and other irregularities that are inherent in commercial utility power. Working with a vessel's electrical system, the UPS system supplies clean, consistent power that sensitive electronic equipment requires for reliable operation. During brownouts, blackouts, and other power interruptions, batteries provide emergency power to safeguard operation.

The UPS system is housed in single freestanding cabinets. The cabinets line up and match in style and colour, and have safety shields behind the doors for hazardous voltage protection.

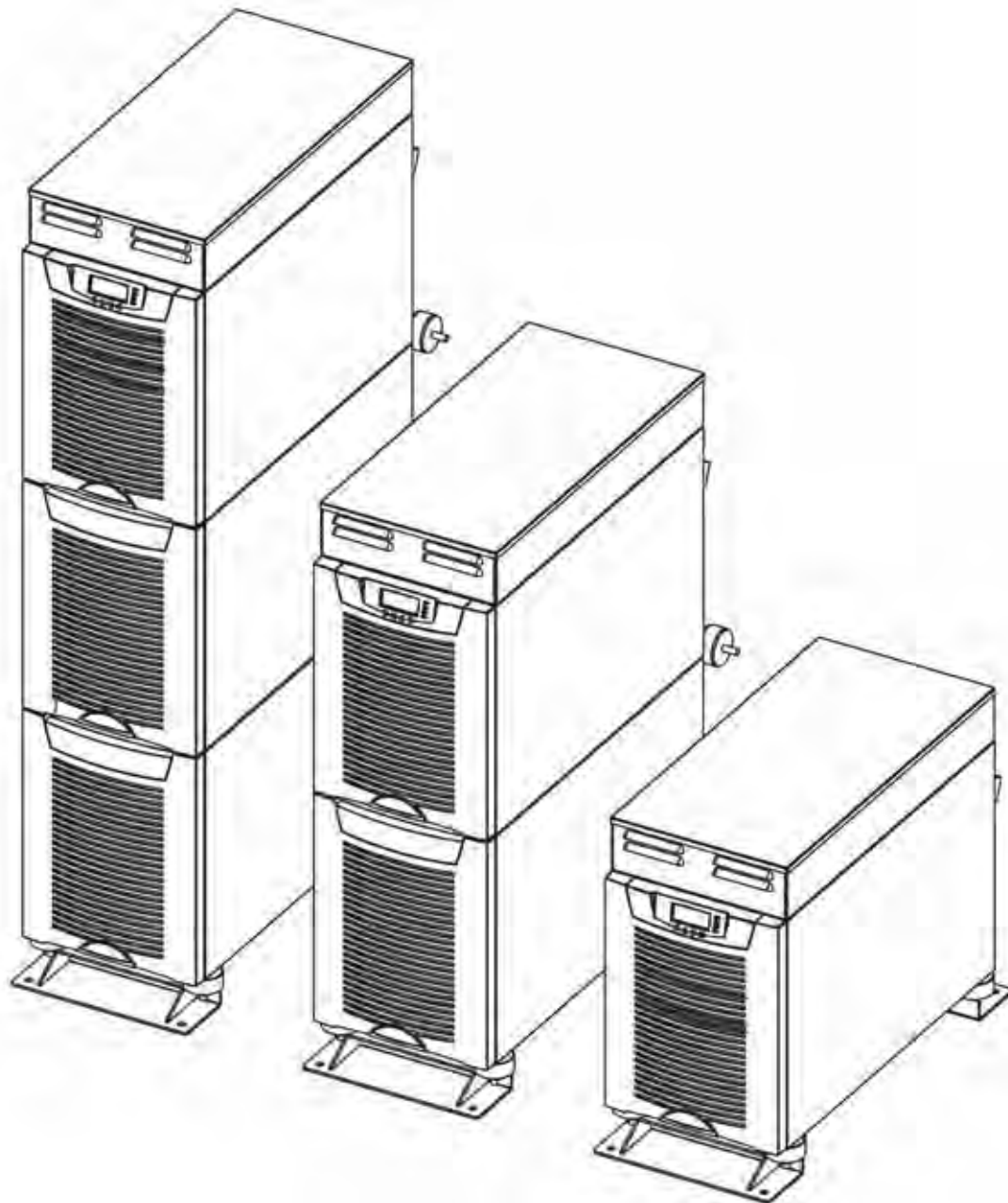

Figure 2-1: Marine UPS units 8-15 kVA type approved models

2.2 Active-Front technology

Traditional input THD filters are no longer needed with this UPS product. The build-in advanced rectifier technology of UPS modules provides perfect sinusoidal input power quality at 0.99 input power factor with harmonic content less than 5% THD(i). This leads to more reliable total system operation and savings in generator and transformer sizing as losses in the windings are minimised.

Due to the active front rectifier, the UPS is comparable to a clean resistor load from the mains perspective. Thus, the high input power factor provides minimised cabling and fusing costs due to no reactive power consumption.

The low harmonic currents are due to high input power factor and provide the benefits:

- No additional losses in wires and cables
- No extra heating of transformers and generators with shortened service life
- No false circuit breaker tripping and malfunction
- No erratic operation of computers, telecommunication, monitors, electronic test equipment etc.
- No Resonance with power factor correction capacitors

2.3 Advanced Battery Management (ABM)[™]

The ABM monitors the status of the battery and charges it only when the battery needs charging. This is the key to long battery life with the ABM due to low generation of corrosion inside the battery. It also monitors that the load never crashes because of bad or defected battery.

The main cause for corrosion is current flowing through battery. The more current going through battery, the shorter the battery life. Current flows through battery when it is discharged or charged. There is very little that can be done for discharging, because it depends on number of power outages in utility line.

The ABM is very valuable feature since most of the time battery does not need any charging. The charging is controlled and initiated on the following occasions:

- When turning the unit on
- After maximum 28 days without charging
- If the open cell voltage decreases below predetermined voltage level

Hence, the function of ABM system is to prolong the battery life considerably compared to traditional system that uses float-charging technology. This means that there is no current going through batteries all the time and causing corrosion. In a traditional online UPS the inverter also causes ripple-current to be fed to batteries causing corrosion.

2.4 Hot Sync[®] technology

The UPS product features U.S. #5,745,365 patented paralleling technology that provides N+X redundancy without introducing a single-point-of-failure. The products utilising the Hot Sync are completely autonomous and the only thing common among them is the critical output power bus.

The Hot Sync is 100% mathematical firmware that makes it more reliable than traditional paralleling techniques. Because the solution is implemented intrinsically, and Hot Sync is always active, the UPS modules do not know whether or not they are even in parallel.

A parallel UPS system means the linking together of two or more UPS units in parallel so that in the unlikely event one fails the other can automatically take up the load. Traditionally a parallel redundancy configuration is achieved by having a random or fixed master-slave relationship among the UPS units. This master logic gives out individual commands to all the slaves units. This master logic gives out individual commands to all the slaves units, but if the master logic or communication to slaves fails, it can lead to a single-point-of-failure for the whole system, and cause the whole UPS system to be in trouble.

The Hot Sync® technology was developed to allow parallel capacity system and to maintain the highest system availability. An industry leading paralleling technology in its own right, the patented Hot Sync enables you to set up a parallel redundant system giving you 100% conditioned power at all times. Its unique digital design eliminates the system level single point of failure inherent in traditional parallel UPS modules, and exponentially increases the reliability of the overall system.

Hot Sync allows up to four UPS units to cover the same load in parallel and redundant configuration. No vulnerable master logic is needed in this patented design. It provides automatic load sharing and module level redundancy with nothing other than the power connecting the Hot Sync version of UPS modules.

2.5 DNV Type approval and ABS product design assessment

Eaton 9155 and 9355 Marine UPS units can also be ordered with RFI filters installed at the factory, making them especially suitable for use with vessel's sensitive bridge equipment. With an RFI filter, the electromagnetic compatibility (EMC) requirements are complied with according to system standard (IEC 60945). This design has Det Norske Veritas (DNV) type approval and American Bureau of Shipping (ABS) product design assessment. To save space, the filter is mounted on the top of the UPS module.

2.6 Basic system configuration

The following basic UPS system configurations are available:

A single UPS system:

- UPS cabinet (Single-phase in/out: 8-10 kVA, three-phase in and single-phase out: 8-10-12-15 kVA, three-phase in/out: 8-10-12-15 kVA)
- Battery cabinets for extended back-up time
- Internal and/or external transformers with multiple input and output voltage choices
- Multilingual LCD display for easy configuration (Std.)
- Basic communication capability (Std.)
- Internal or external Maintenance Bypass Switch (MBS) for isolating the UPS during maintenance, without interrupting continuous power to the load.

Adding optional accessories can enhance the UPS system configuration. These include extensive X-slot communication adapters.

3 Mechanical installation

The UPS and accessories are delivered on a specifically designed pallet that is easy to move with a forklift or a pallet jack. Keep the UPS always in upright position and do not drop the equipment. Do not stack the pallets because of high-energy batteries involved and the heavy weight.

3.1 Delivery check

The UPS is delivered with the following items:

- Plastic bag containing:
 - User's Guide, paper format, English language
 - UPS Safety Manual, multilingual
 - Residual voltage warning stickers
 - Software Suite, CD-ROM format, English language
 - RS-232 serial cable for the Software Suite
- Delivery documents

3.2 Unpacking and visual inspection

Check that there are no signs of shipping damages. The models higher than 1m are equipped with 'Tip&Tel' indicator. The indicator should be intact if the equipment has been transported in the upright position.



O TE

A claim for shipping damage must be filed immediately and the carrier must be informed within 7 days of receipt of the equipment. The packing materials should be stored for further investigation.

Before unpacking, use a forklift or pallet jack to move the equipment as close as possible to the installation site. Unpack the equipment by removing the packing and shipping materials. Make a visual inspection and check that the inside 'Drop&Tel' indicator is intact. Make sure that the floor surface is solid and suitable for heavy weight and remove the equipment slowly from the pallet using lifting belts or other suitable method. Be sure to always lift from the bottom of the unit as the top of the cabinet is not designed to carry any weight. Discard or recycle the pallet and the other shipping materials in a responsible manner.

Check the information on the type designation label of the equipment to verify that the unit is of the correct type. The type designation label includes ratings, a CE marking, a type code, a part number and a serial number. The serial number is important when making inquiries. It allows individual recognition of the equipment.

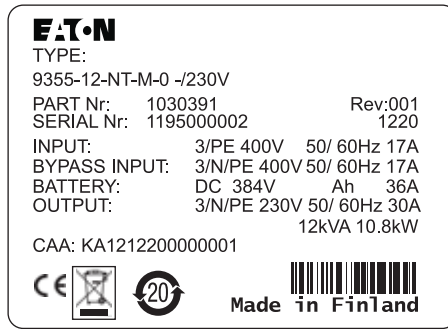

Figure 3-1: Type designation label

4 Planning before installation

The equipment must be installed in upright position and it requires space both front and back side to enable cooling airflow. The cooling air enters the unit through air inlets in the front and exits from the rear of the unit. The required minimum clearance from unit rear to an obstruction is 150 mm. For service and maintenance, 500 mm of empty space above the UPS unit is also required.

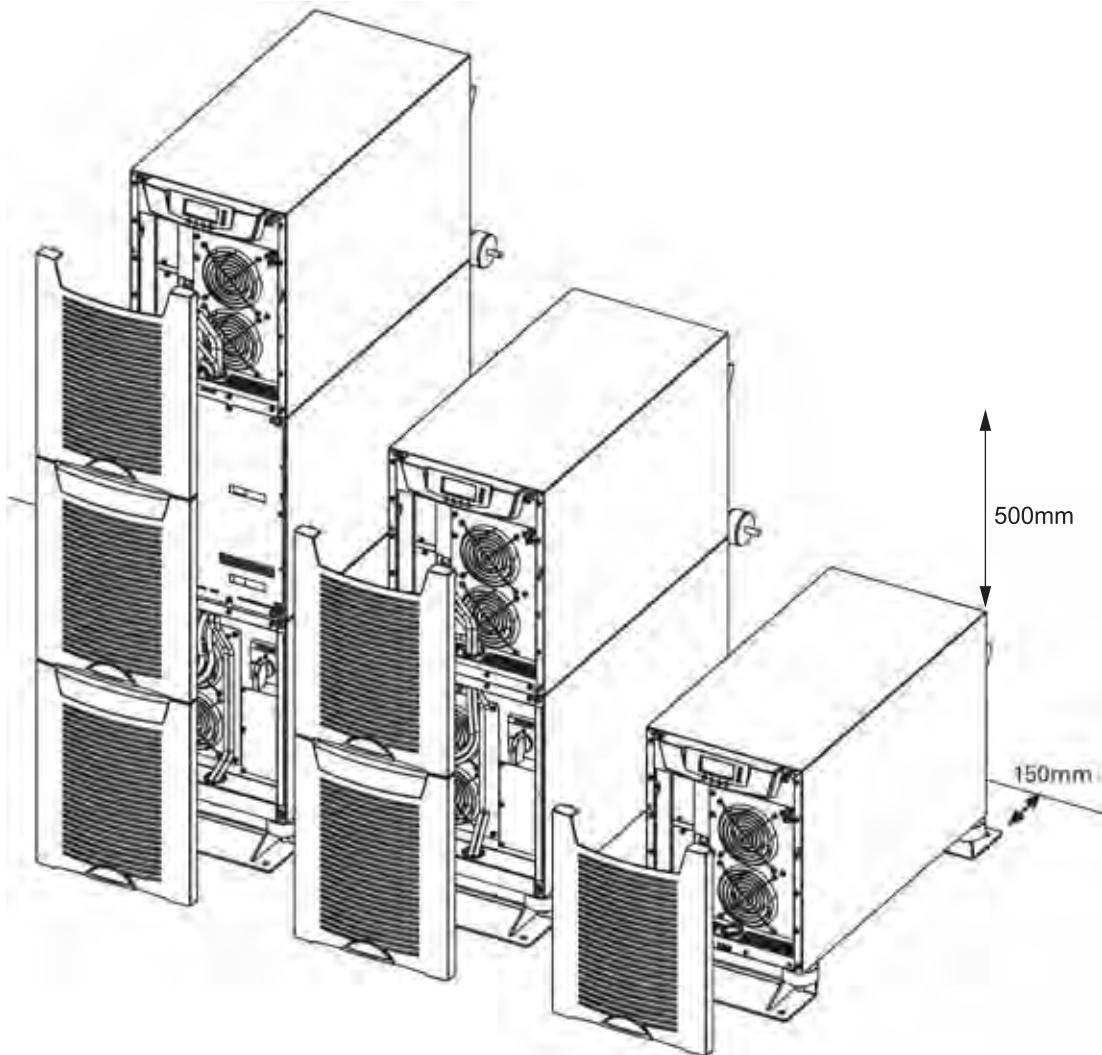

Figure 4-1: Marine UPS units 8-15 kVA

It is required to arrange ventilation of the UPS room. Sufficient amount of air cooling is needed to keep the max. room temperature rise at desired level:

- Temperature rise of max. +5°C requires the airflow of 600 m³ per 1 kW of losses.
- Temperature rise of max. +10°C requires the airflow of 300 m³ per 1 kW of losses.

An ambient temperature of 15 to 25 Celsius degrees is recommended to achieve a long life of the UPS and batteries. The cooling air entering the UPS must not exceed +45 °C. Avoid high ambient temperature, moisture and humidity.

The floor material should be non-flammable and strong enough to support the heavy load.

Equipment Standard	Weight (kg)	Point (kg/cm ²)	Distributed (kg/m ²)	ote
UPS	58	0,09	272	No batteries
UPS + BAT	161	0,25	754	Batteries installed
UPS + 2 BAT	265	0,41	1241	Batteries installed
UPS + BAT (EMPTY)	81	0,13	379	No batteries installed
UPS + 2 BAT (EMPTY)	105	0,16	492	No batteries installed
UPS + TRAFO	161	0,25	754	No batteries
UPS + TRAFO + BAT	243	0,38	1138	Batteries installed
2 BAT	217	0.34	1016	Batteries installed
3 BAT	323	0.50	1513	Batteries installed

Table 4-1: The floor surface must withstand these weights (Standard models)

Equipment TA model	Weight (kg)	Point (kg/cm ²)	Distributed (kg/m ²)	ote
UPS	68	0,11	319	No batteries
UPS + BAT	171	0,27	801	Batteries installed
UPS + 2 BAT	275	0,43	1288	Batteries installed
UPS + BAT (EMPTY)	91	0,14	426	No batteries installed
UPS + 2 BAT (EMPTY)	115	0,18	539	No batteries installed
UPS + TRAFO	171	0,27	801	No batteries
UPS + TRAFO + BAT	253	0,40	1185	Batteries installed
2 BAT	217	0.34	1016	Batteries installed
3 BAT	323	0.50	1513	Batteries installed

Table 4-2: The floor surface must withstand these weights (TA models)

5 Cabinet installation

The required distance for UPS units next to each other is 10 mm, but for maintenance and service purposes, it is recommended to leave 100 mm space on both sides of the unit when possible. The same applies to the optional battery cabinets that should be installed next to the UPS cabinet.

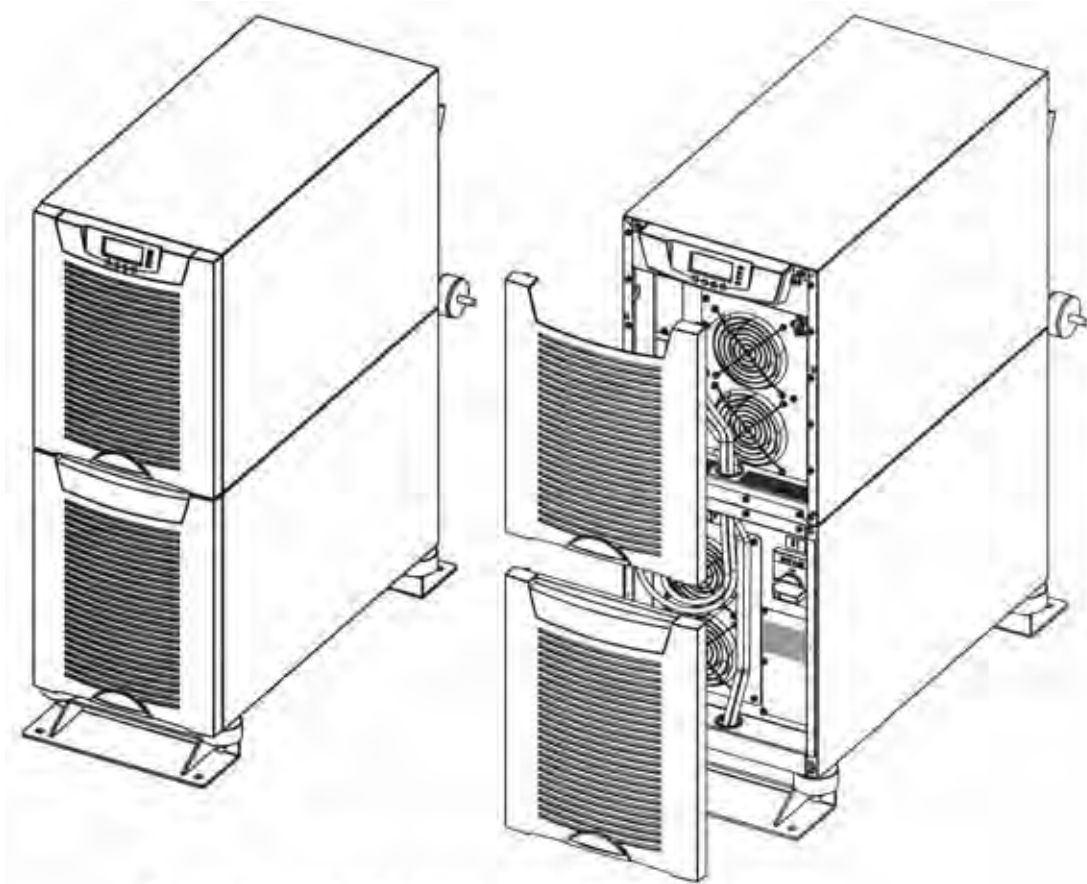

To remove a plastic cover, place your hand on the bottom of the cover plate and push upwards

Figure 5-1: Marine UPS unit with internal input transformer

The UPS family has several alternative battery cabinets and configurations depending on the selected back-up time and quality of batteries.

.1 Maintenance bypass switch

UPS models with an integrated input transformer are supplied with an internal maintenance bypass switch (MBS). The MBS may also be ordered as an integrated MBS mounted on the back of the UPS, or as a separate MBS for wall mounting near the UPS. The internal MBS and the rear-mounted MBS are factory installed.

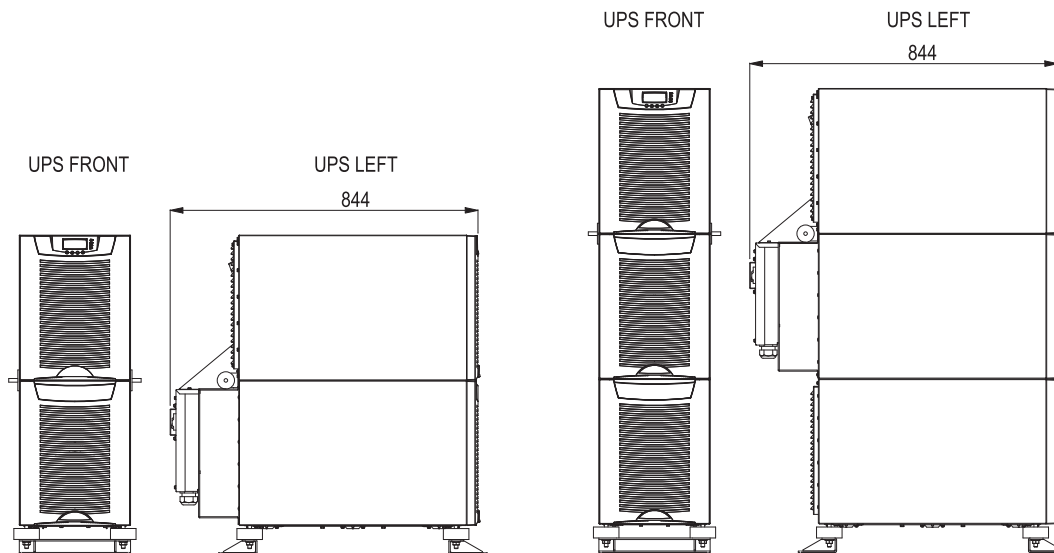

Figure 5-2: UPS with battery module(s) and the rear mounted mechanical bypass switch

.2 Transformer option

The galvanic isolation transformer can be ordered as factory installed. The transformer is an integral part of the UPS unit and it can be connected to the input or the output of the system. Systems with factory installed transformers are referred to as: 9155 NT-model (3 phase in, 1 phase out), 9155 ST-model (1 phase in, 1 phase out) or 9355 NT-model (3 phase in, 3 phase out). With transformers, UPS can also operate in different voltages. Transformer configurations and operation voltages can be customized to match the customer needs. Alternatively, isolation transformers can be purchased as separate items.

The over temperature sensor cable from the transformer module is connected to the control input (X44) and the status information from the maintenance bypass switch is connected to the control input (X45). In the factory installed systems these cables are ready-made for use.

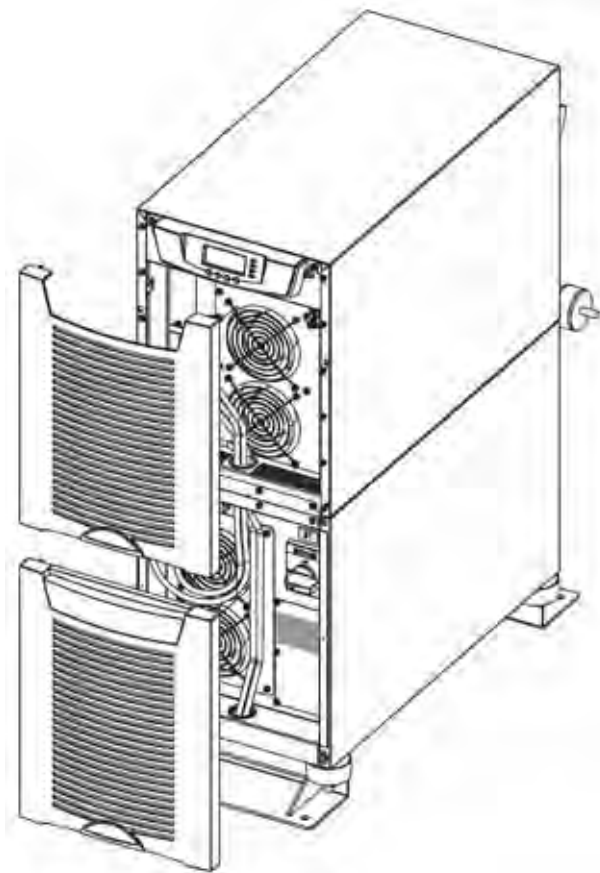

Figure 5-3: UPS unit with the factory installed isolation transformer

.3 External battery cabinet option

It's recommended to install external battery cabinets next to the UPS unit. The battery cabinet can be placed on either side of the UPS unit. Before the installation, check that the battery voltage values, in the type plate of the UPS and the external battery cabinets, are the same. The cables are delivered with the external battery cabinets. See *Chapter 6.3 External Battery Cabinet (EBC) installation procedure* on page 37.



WARNING

The UPS contains high DC voltages. A qualified person must do the connections between the UPS and the external battery cabinet(s). The battery cabinet is connected electrically in parallel with the internal batteries of the UPS.

.4 Battery racks

External battery racks shall be sized to take the voltage drop in the cable into account. To obtain support and help contact the local office or agent authorised by the manufacturer.

6 Electrical installation

The customer has to supply the wiring to connect the UPS to the local power source. The electrical installation procedure is described in the following text. The installation inspection and initial start up of the UPS and extra battery cabinet shall be carried out by a qualified engineer with UPS installation experience.



WARNING

Physical injury or death may follow, or damage may occur to the UPS, or the load equipment if these instructions are ignored.

The UPS unit has the following power connections:

Rectifier input:

- Three-phase (L1, L2, L3) and protective earth (PE) connection
- Single-phase (L1) and protective earth (PE) connection. Neutral (N) has isolated connection point and Neutral from the bypass input is used in the rectifier. N can work also as L2.

Bypass input:

- Three-phase (L1, L2, L3), Neutral (N) and protective earth (PE)
- Single-phase (L1), Neutral (N) and protective earth (PE) connection. N can work also as L2.

Load output:

- Three-phase (L1, L2, L3), Neutral (N) and protective earth (PE) connection
- Single-phase (L1), Neutral (N) and protective earth (PE) connection. N can work also as L2.

Battery:

- Plus (+), minus (-) and protective earth (PE) connection for the external batteries.



OTE

The rectifier requires a Neutral (midpoint) to operate. It's connected internally from the bypass terminal to the rectifier, see wiring diagrams later in this chapter.



OTE

Care needs to be taken to ensure that the input supply neutral reference is not disconnected whilst the UPS is in service.

6.1 Power cables and protective fuses

Always use copper cable types to fit terminals with approximately 1.5 Nm torque for different load currents. The Cu cable sizing is based on multi-core cables laid in conduits/trunkings on the wall or on the floor (installation procedure C), ambient temperature 25°C, PVC insulation, surface temperature up to 70°C. Cables of several UPS can be installed in parallel to each other.

Standards SFS 6000-5-52 (2002) and IEC 60364-5-52 (2001-08) "Electrical installations of buildings" with normal 1.7 x Neutral conductor rating for IT loads are used as a sizing guide. For any other conditions, size the cables according to the local safety regulations regarding installation environment, appropriate voltage and currents of the UPS.

Fuses are sized according to local safety regulations, appropriate input voltage and the rated current of the UPS. Therefore, protect the input and bypass cables with gG (gL) fuses or B-C-D type of circuit breakers against overload and short-circuit.

Contact the manufacturer's authorised agent or the local office for assistance at fuse and cable sizing. Refer to the recommended cable and fuse ratings in the tables presented with the wiring diagrams.

6.2 Wiring procedure

Depending on the model the power cable terminals can be located either in the back of the UPS unit, in the front of the factory installed transformer or on top in Type Approved (TA) models. The qualified engineer is responsible for the correct electrical installation. They must be authorised by the manufacturer.

6.2.1 UPS models without an internal transformer

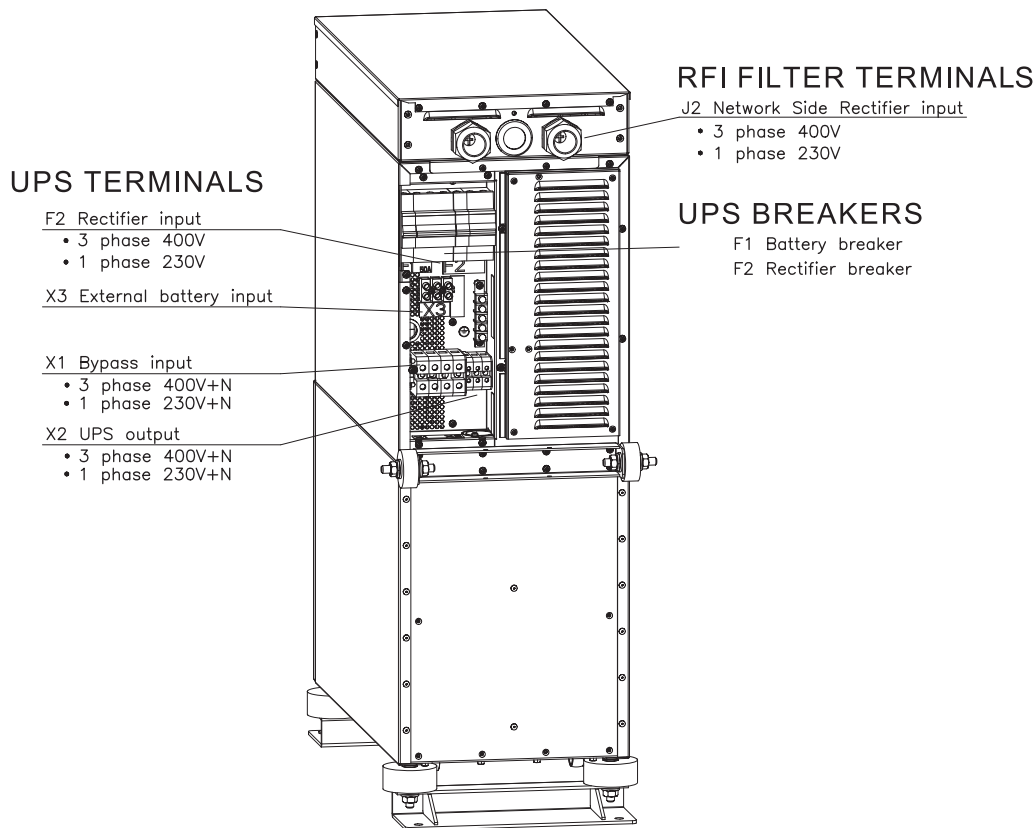

Figure 6-1: The location of the power terminals for UPS unit without an internal transformer

The installation procedure for models without an internal transformer is described below.

1. Remove the cover(s) of the terminal box of the power cables with a screwdriver. In TA models rectifier input cables are connected to the filter, which is located on top of the unit. Refer to the dimensional drawing for the correct location of the unit.
2. Slide the cables through the grommets of the connection box.
3. Connect the conductors of the rectifier and bypass input cables to the proper terminals. With single phase unit it is recommended to use the same phases for rectifier and bypass inputs.
4. Connect the conductors of the load cable to the proper terminals.
5. Connect the conductors of an external battery cabinet cable to the external battery +, - and PE terminals. Check for the correct polarity. See *Chapter 6.3 External Battery Cabinet (EBC) installation procedure* on page 37.



WARNING

If available, the internal battery has to be disconnected first because the external battery terminals are hazardous due to the parallel battery string.

6. Secure the cables with the grommets in the connection box.
7. Fasten the cover of the terminal box and filter enclosure with a screwdriver.

The IEC/EN 62040-1 safety instructions require the fitting by the user of a warning label on all primary power isolators installed remote from the UPS area. The warning label for electrical maintenance personnel shall carry the following wording or equivalent:

“ISOLATE UNINTERRUPTIBLE POWER SUPPLY (UPS) BEFORE WORKING ON THIS CIRCUIT.”

A readily accessible disconnect device shall be incorporated in the building installation wiring as shown in diagrams.

6.2.2 UPS models with an internal input transformer

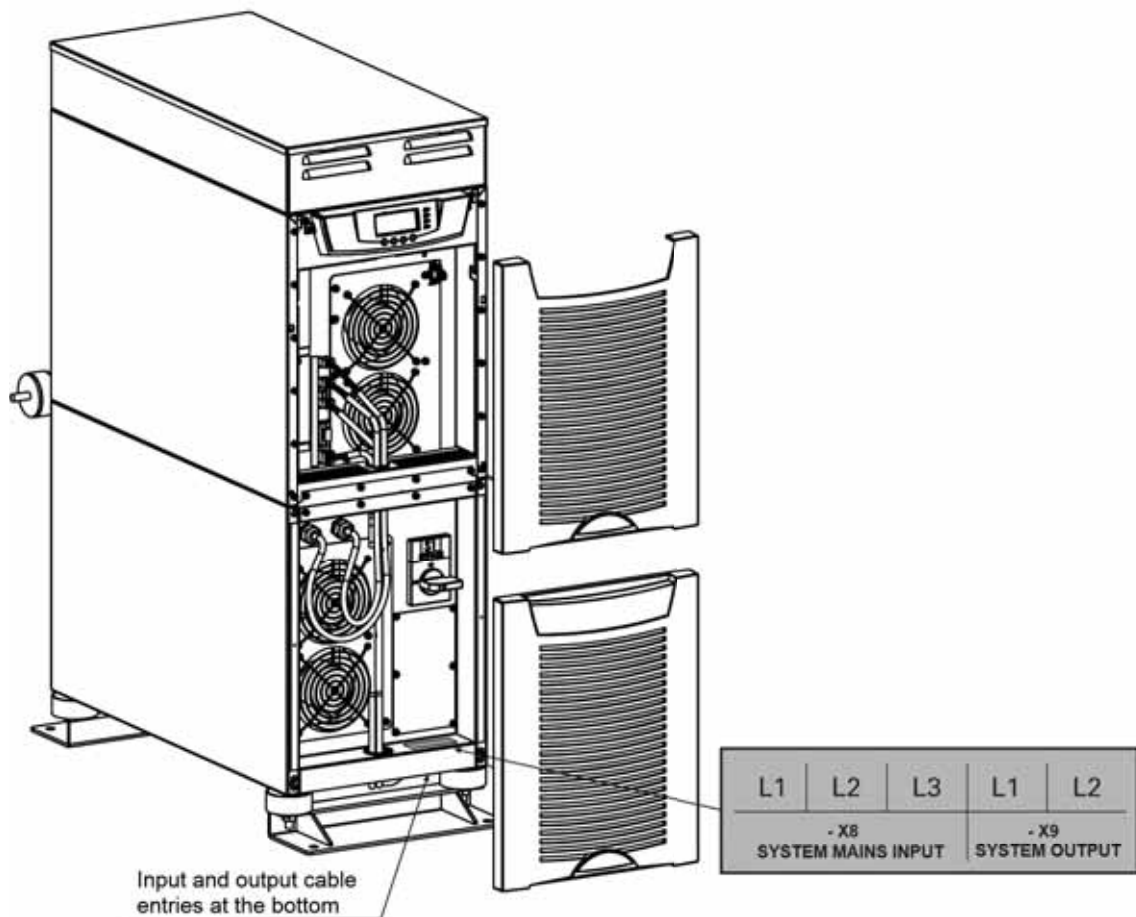

Figure 6-2: The location of the power terminals for UPS unit with an internal input transformer

The installation procedure for models with an internal input transformer is described below.

1. Remove the plastic front cover of a transformer.
2. Remove the cover of the terminal box of the power cables with a screwdriver. Refer to the dimensional drawing for the correct location at the front of the unit.
3. Slide the cables through the membrane glands from the bottom of the unit.
4. Connect the input cables to the proper terminals.
5. Connect the conductors of the load cable to the proper terminals in the same section.

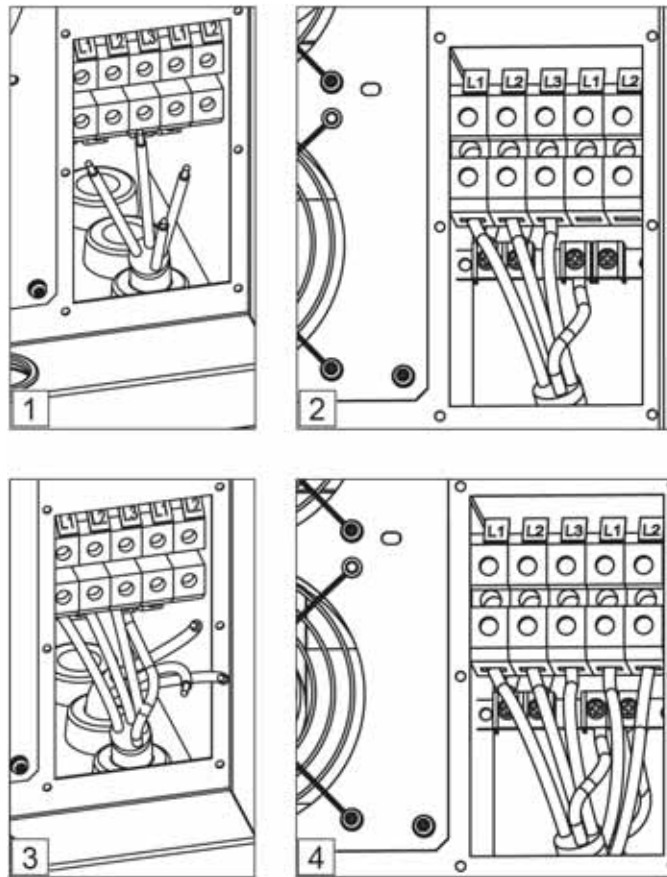

Figure 6-3: Cable connections into a transformer section

6. Connect the conductors of an external battery cabinet cable to the external battery +, - and PE terminals. Check for the correct polarity. See *Chapter 6.3 External Battery Cabinet (EBC) installation procedure* on page 37.



WARNING

If available, the internal battery has to be disconnected first because the external battery terminals are hazardous due to the parallel battery string.

7. Fasten the cover of the terminal box with a screwdriver.
8. Fasten the plastic front cover of a transformer.

The IEC/EN 62040-1 safety instructions require the fitting by the user of a warning label on all primary power isolators installed remote from the UPS area. The warning label for electrical maintenance personnel shall carry the following wording or equivalent:

“ISOLATE UNINTERRUPTIBLE POWER SUPPLY (UPS) BEFORE WORKING ON THIS CIRCUIT.”

A readily accessible disconnect device shall be incorporated in the building installation wiring as shown in diagrams.

6.2.3 UPS models with an internal output transformer

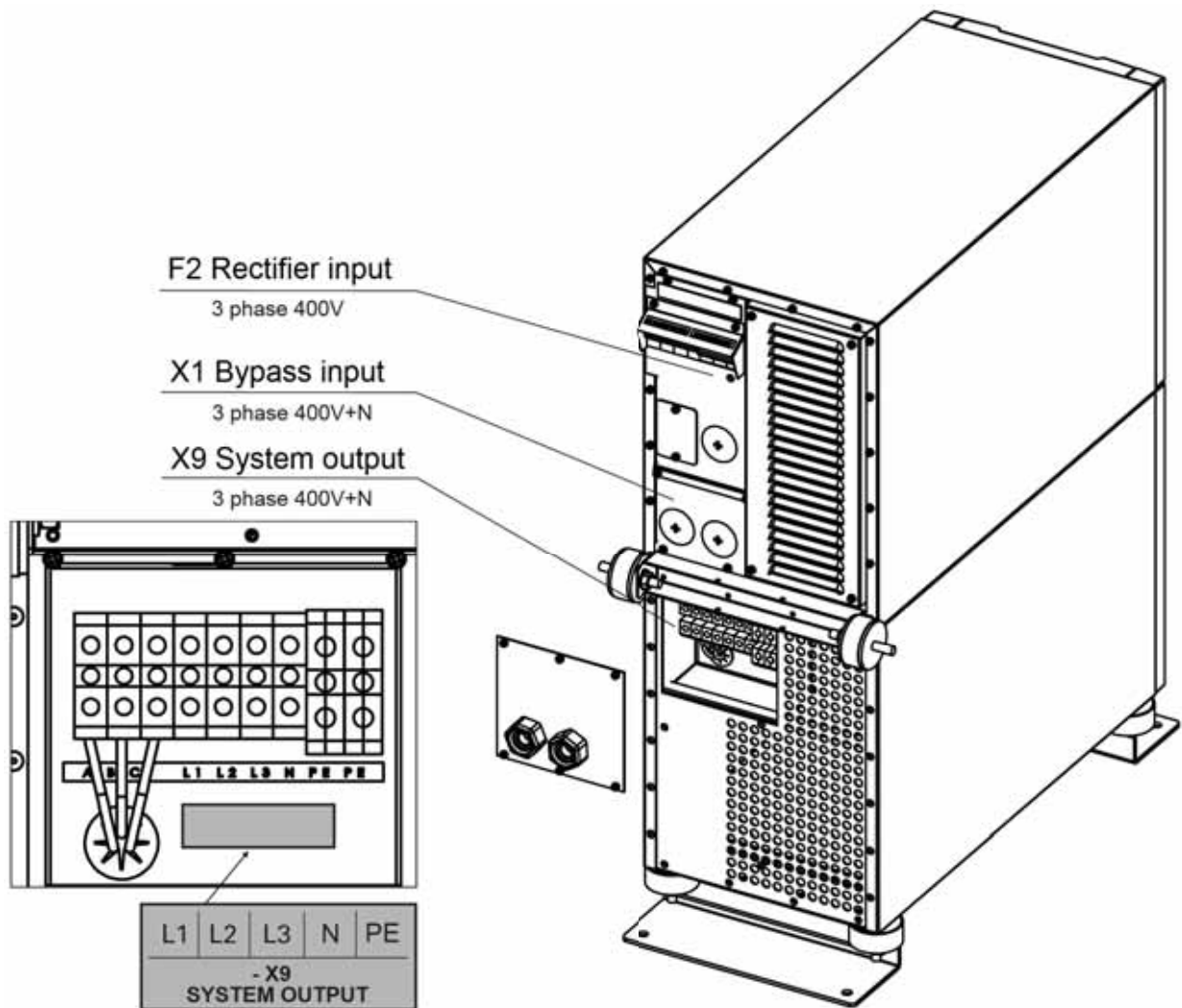

Figure 6-4: The location of the power terminals for UPS unit with an internal output transformer

The installation procedure for models with an internal output transformer is described below.

1. Remove the cover(s) of the terminal box of the power cables with a screwdriver. In TA models rectifier input cables are connected to the filter, which is located on top of the unit. Refer to the dimensional drawing for the correct location of the unit.
2. Slide the cables through the grommets of the connection box.
3. Connect the conductors of the rectifier and bypass input cables to the proper terminals. With single phase unit it is recommended to use the same phases for rectifier and bypass inputs.
4. Connect the conductors of the load cable to the proper terminals at the back of the transformer.
5. Connect the conductors of an external battery cabinet cable to the external battery +, - and PE terminals. Check for the correct polarity. See *Chapter 6.3 External Battery Cabinet (EBC) installation procedure* on page 37.



WARNING

If available, the internal battery has to be disconnected first because the external battery terminals are hazardous due to the parallel battery string.

6. Secure the cables with the grommets in the connection box.
7. Fasten the cover of the terminal box and filter enclosure with a screwdriver.

The IEC/EN 62040-1 safety instructions require the fitting by the user of a warning label on all primary power isolators installed remote from the UPS area. The warning label for electrical maintenance personnel shall carry the following wording or equivalent:

“ISOLATE UNINTERRUPTIBLE POWER SUPPLY (UPS) BEFORE WORKING ON THIS CIRCUIT.”

A readily accessible disconnect device shall be incorporated in the building installation wiring as shown in diagrams.

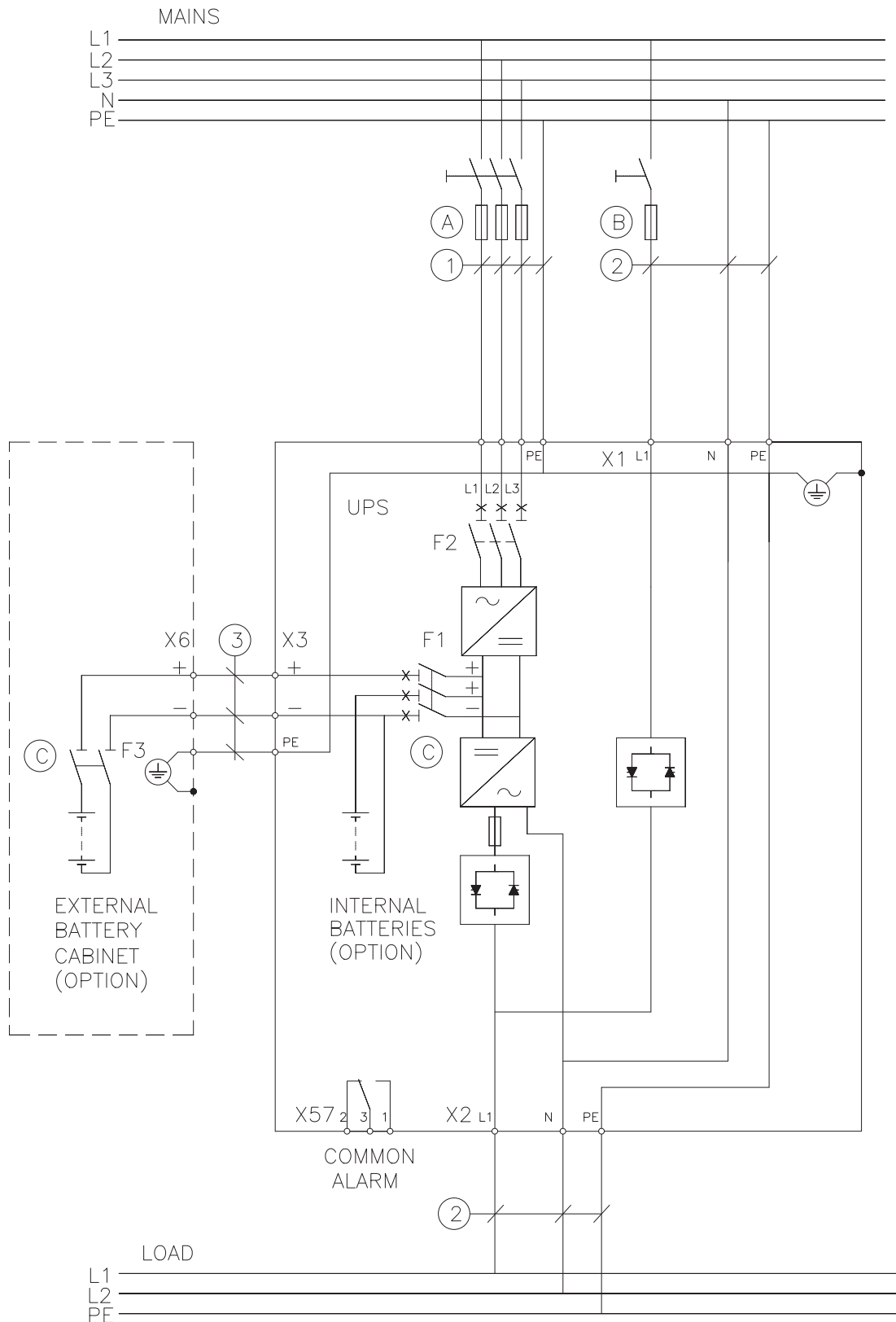

Figure 6-5: Wiring diagram of 9155 N-model (3-phase in / 1-phase out). For cable and fuse sizes, see the Table 6-1.

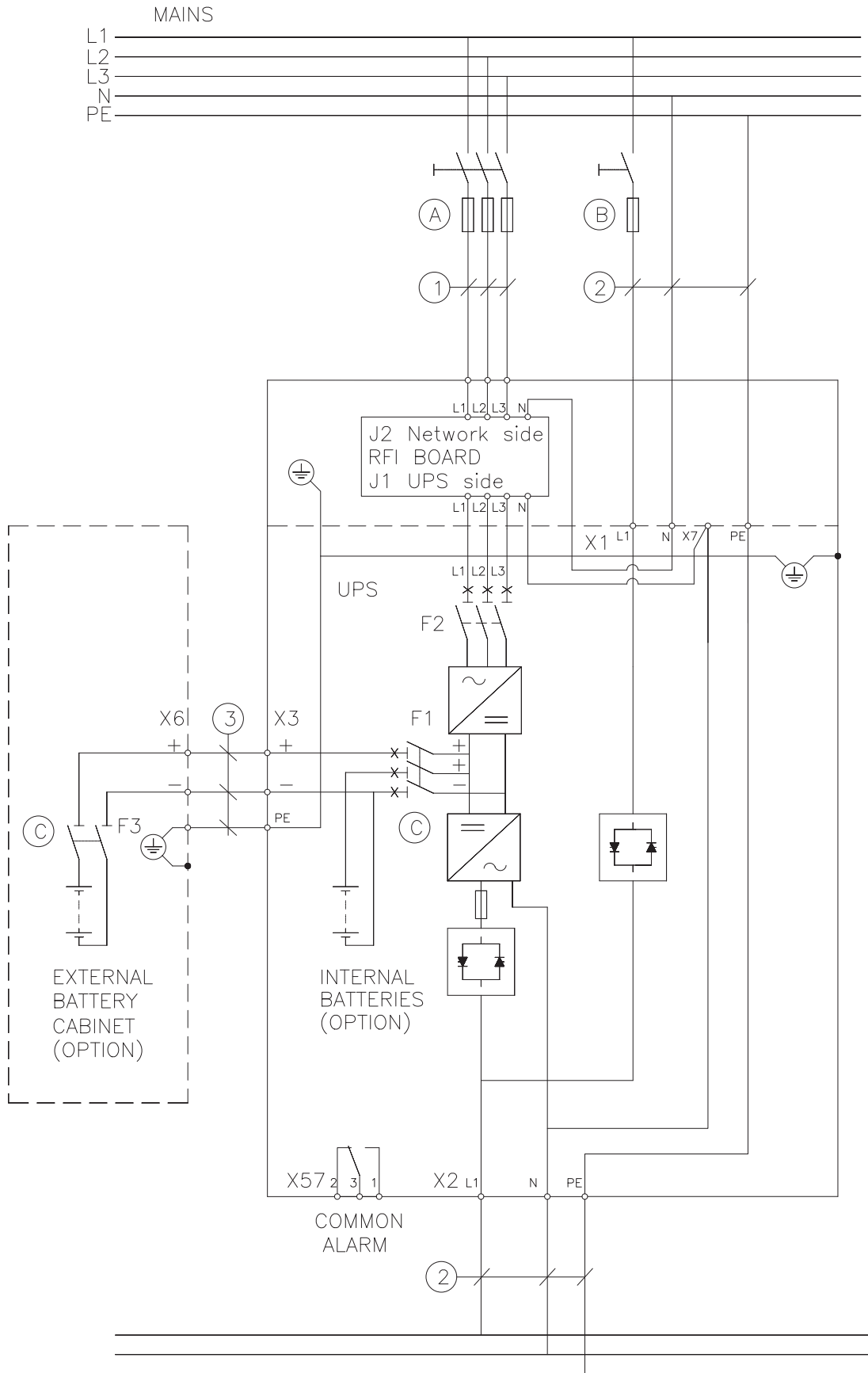

Figure 6-6: Wiring diagram of type approved 9155 N-model (3-phase in / 1-phase out). For cable and fuse sizes, see the Table 6-1.

9155 (3P in/1P out)	RECTIFIER INPUT		BYPASS INPUT	
UPS rating (kVA)	Fusing (FUSE A)	Cabling (CABLE 1)	Fusing (FUSE B)	Cabling (CABLE 2)
8 kVA	25 A	6 mm ²	50 A	10 mm ²
10 kVA	25 A	6 mm ²	50 A	10 mm ²
12 kVA	40 A	10 mm ²	63 A	16 mm ²
15 kVA	50 A	10 mm ²	80 A	16 mm ²

9155 (3P in/1P out)	PE	Output		Battery	
UPS rating (kVA)	Cabling (CABLE 2)	Nominal current	Cabling (CABLE 2)	Fusing (FUSE A)	Cabling (CABLE 3)
8 kVA	10 mm ²	38.8 A	10 mm ²	50 A	10 mm ²
10 kVA	10 mm ²	43.5 A	10 mm ²	50 A	10 mm ²
12 kVA	16 mm ²	52.2 A	16 mm ²	50 A	10 mm ²
15 kVA	16 mm ²	65.2 A	16 mm ²	50 A	10 mm ²

Table 6-1: Recommended cable and fuse sizes for 9155 N-model (No transformer)

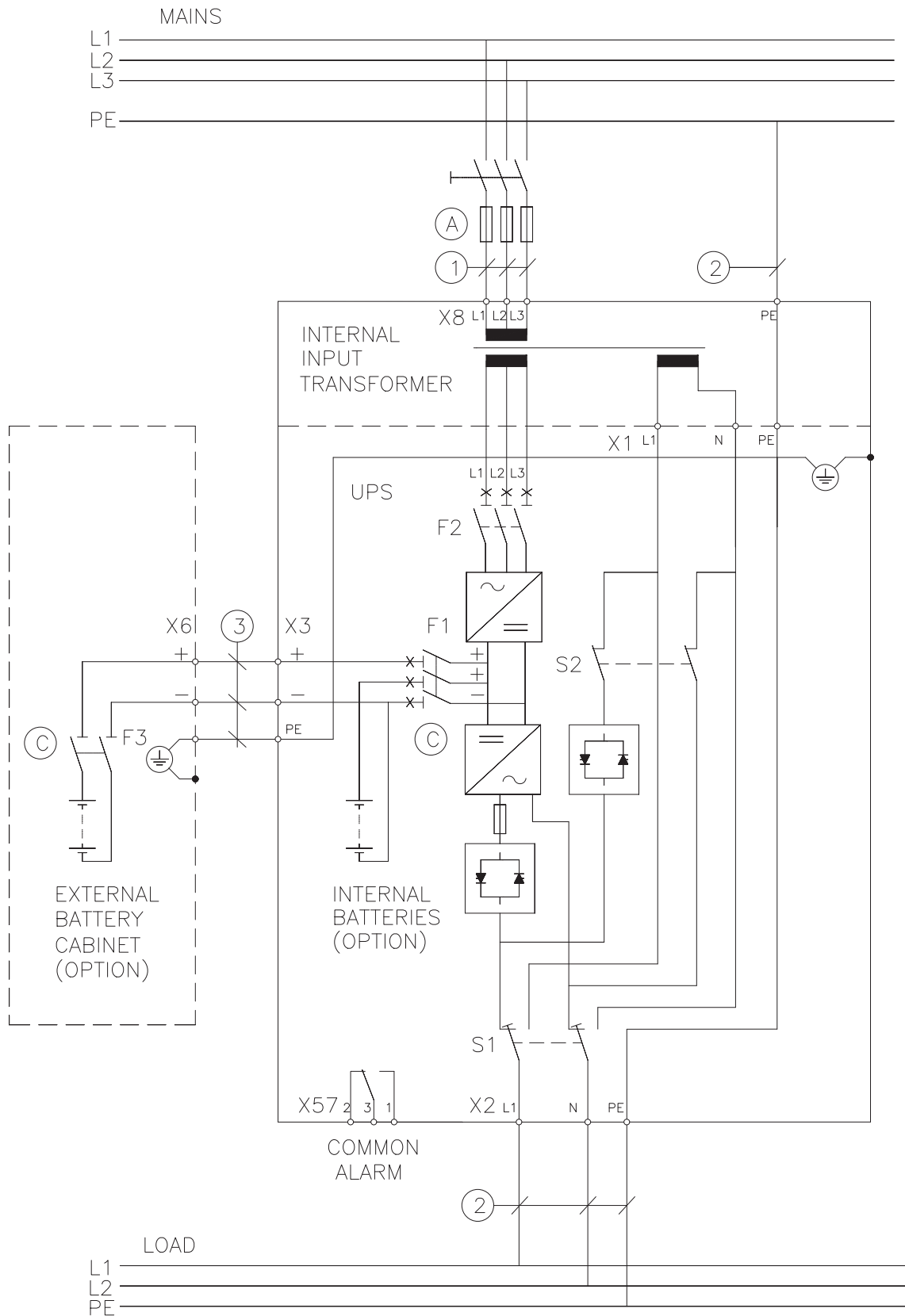

Figure 6-7: Wiring diagram of 9155 NT-model with internal MBS (3-phase in / 1-phase out). For cable and fuse sizes, see the Table 6-2.

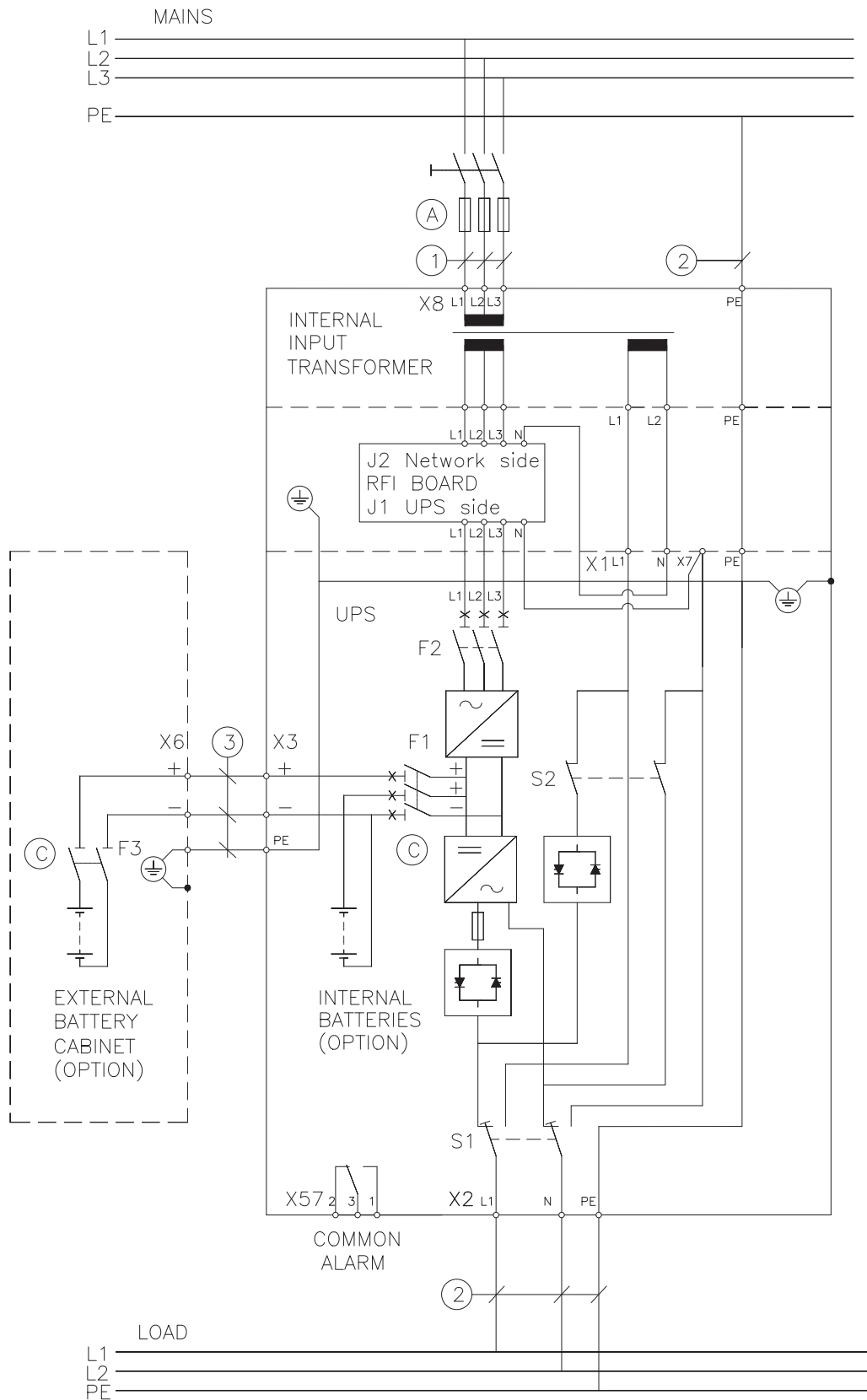

Figure 6-8: Wiring diagram of type approved 9155 NT-model with internal MBS (3-phase in / 1-phase out). For cable and fuse sizes, see the Table 6-2.

9155 (3P in/1P out)	Input									
	Fusing (FUSE A) with different input voltages					Cabling (CABLE 1) with different input voltages				
UPS rating (kVA)	230 V	400 V	440 V	480 V	690 V	230 V	400 V	440 V	480 V	690 V
8 kVA	50 A	25 A	25 A	20 A	20 A	10 mm ²	6 mm ²	6 mm ²	6 mm ²	6 mm ²
10 kVA	50 A	25 A	25 A	25 A	20 A	10 mm ²	6 mm ²	6 mm ²	6 mm ²	6 mm ²
12 kVA	63 A	40 A	40 A	25 A	25 A	16 mm ²	10 mm ²	10 mm ²	6 mm ²	6 mm ²
15 kVA	80 A	50 A	50 A	32 A	32 A	16 mm ²	10 mm ²	10 mm ²	6 mm ²	6 mm ²

9155 (3P in/1P out)	PE	Output		Battery	
	Cabling (CABLE 2)	Nominal current	Cabling (CABLE 2)	Fusing (FUSE C)	Cabling (CABLE 3)
8 kVA	10 mm ²	38.8 A	10 mm ²	50 A	10 mm ²
10 kVA	10 mm ²	43.5 A	10 mm ²	50 A	10 mm ²
12 kVA	16 mm ²	52.2 A	16 mm ²	50 A	10 mm ²
15 kVA	16 mm ²	65.2 A	16 mm ²	50 A	10 mm ²

Table 6-2: Recommended cable and fuse sizes for 9155 NT-model

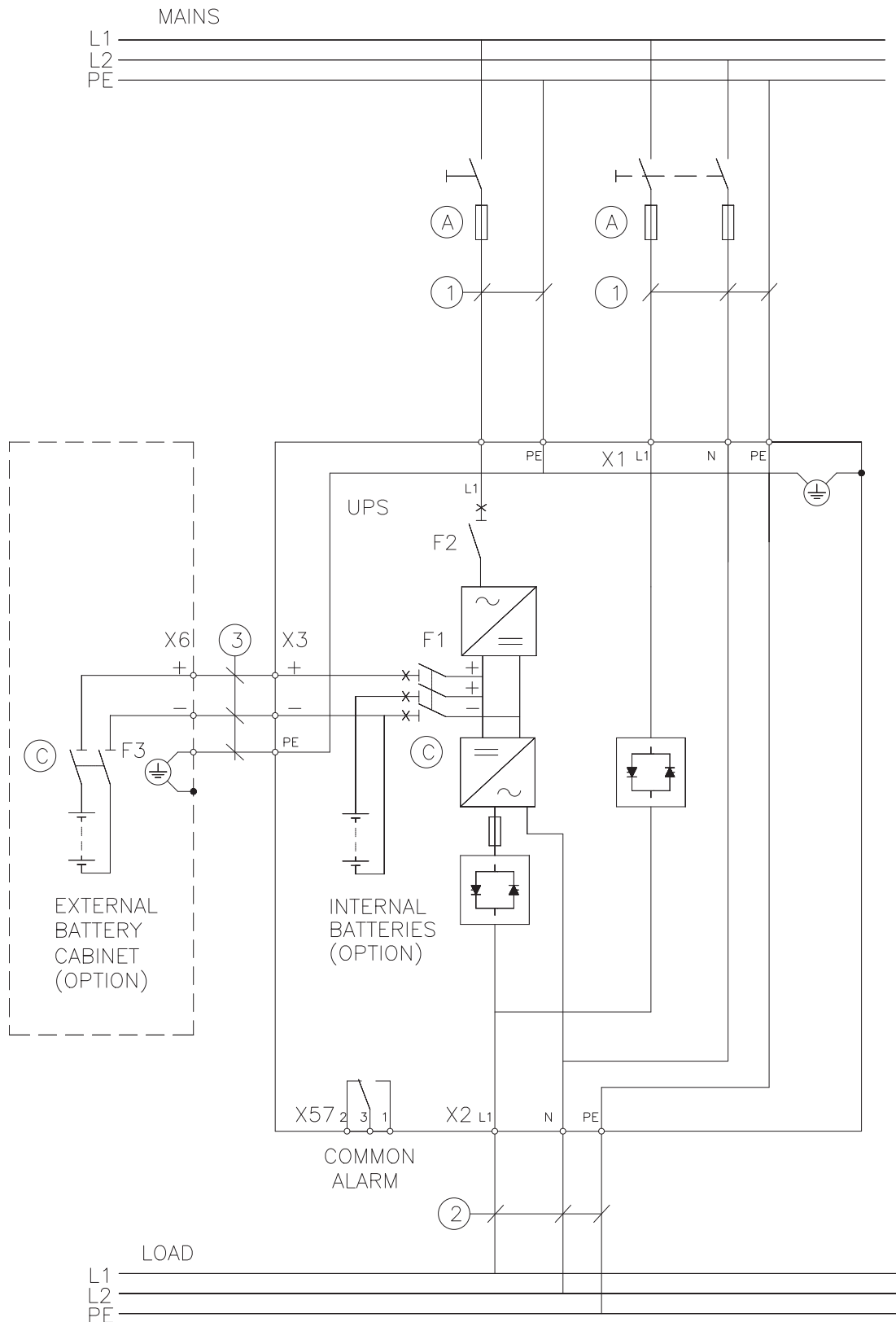

Figure 6-9: Wiring diagram of 9155 S-model (1-phase in / 1-phase out). For cable and fuse sizes, see the Table 6-3.

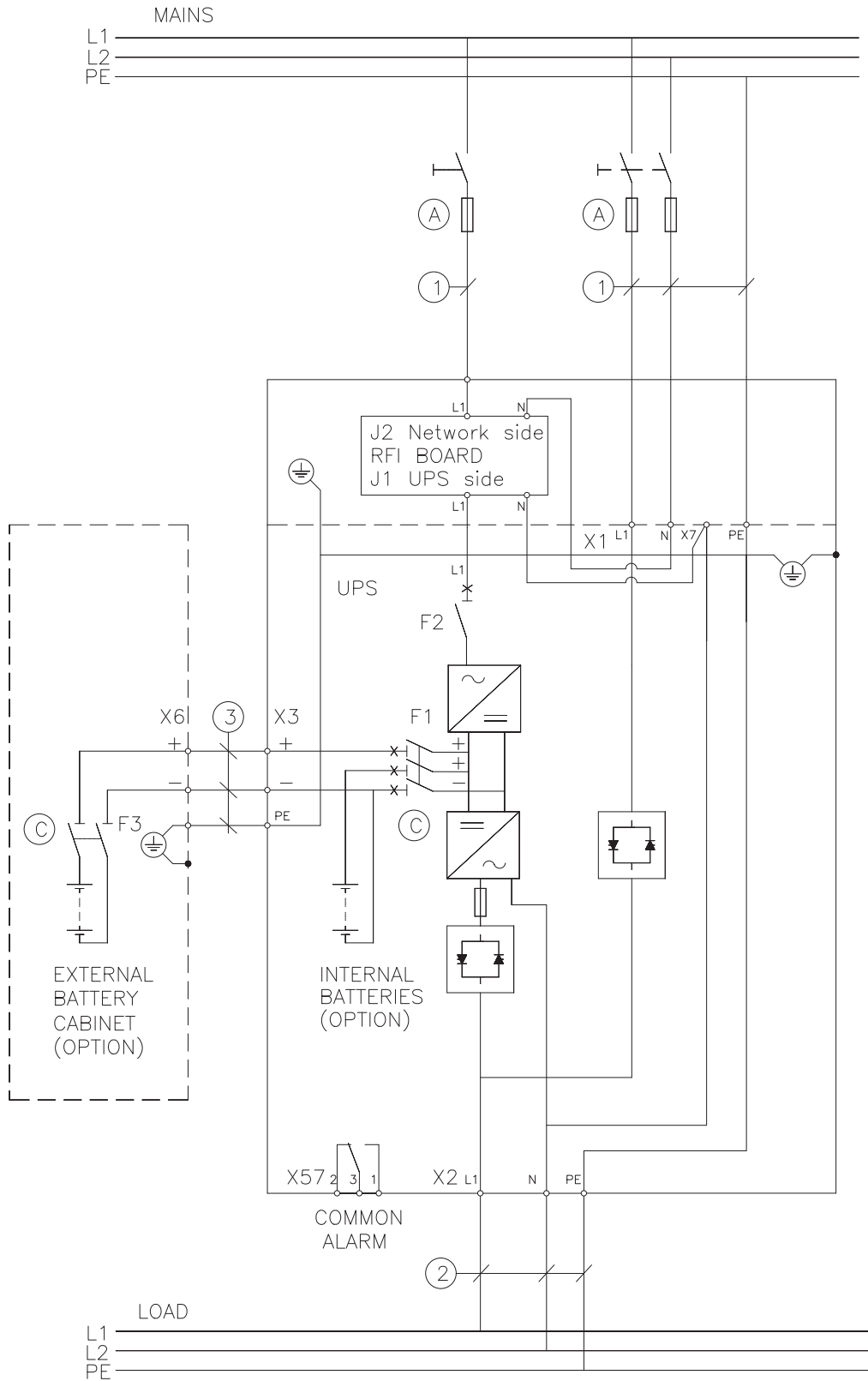

Figure 6-10: Wiring diagram of type approved 9155 S-model (1-phase in / 1-phase out). For cable and fuse sizes, see the Table 6-3.

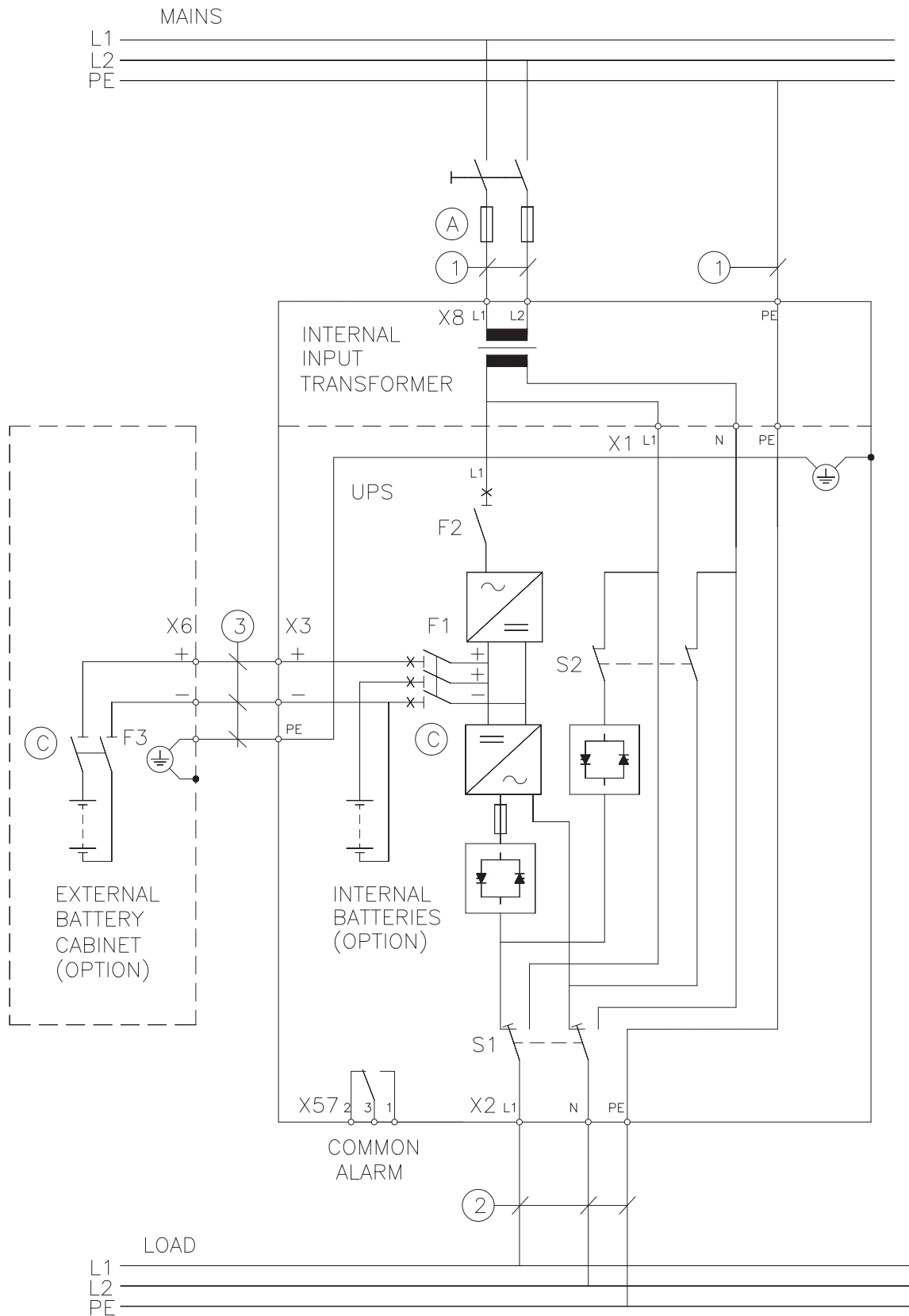

Figure 6-11: Wiring diagram of 9155 ST-model with internal MBS (1-phase in / 1-phase out). For cable and fuse sizes, see the Table 6-3.

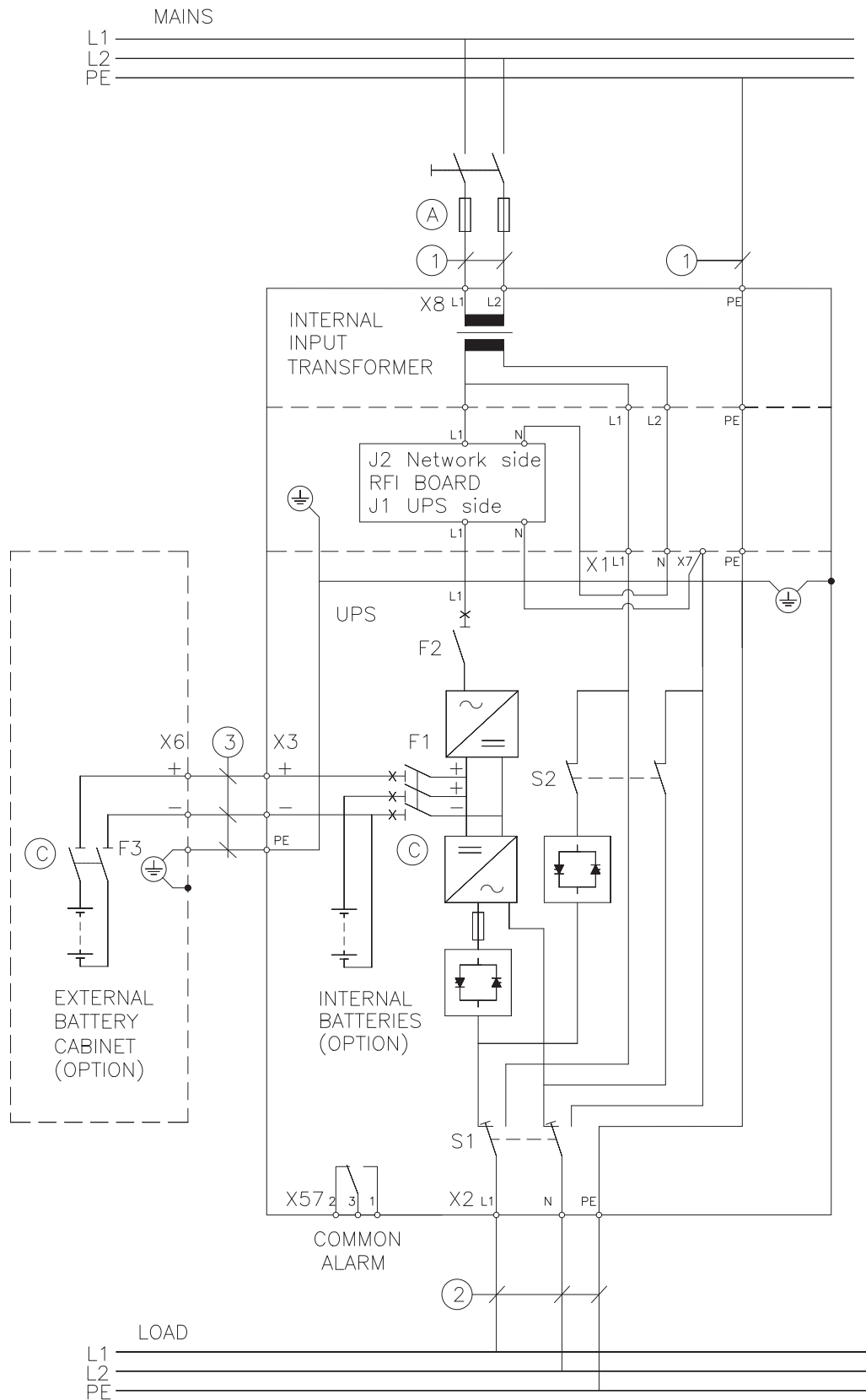

Figure 6-12: Wiring diagram of type approved 9155 ST-model with internal MBS (1-phase in / 1-phase out). For cable and fuse sizes, see the Table 6-3.

9155 (1P in / 1P out)	INPUT		PE	OUTPUT		BATTERY	
	Fusing (FUSE A) Input voltage 230 V	Cabling (CABLE 1) Input voltage 230 V	Cabling (CABLE 1)	Nominal Current	Cabling (CABLE 2)	Fusing (FUSE C)	Cabling (CABLE 3)
8 kVA	50 A	10 mm ²	10 mm ²	38.8 A	10 mm ²	50 A	10 mm ²
10 kVA	50 A	10 mm ²	10 mm ²	43.5 A	10 mm ²	50 A	10 mm ²

Table 6-3: Recommended cable and fuse sizes for 9155 S model and 9155 ST model

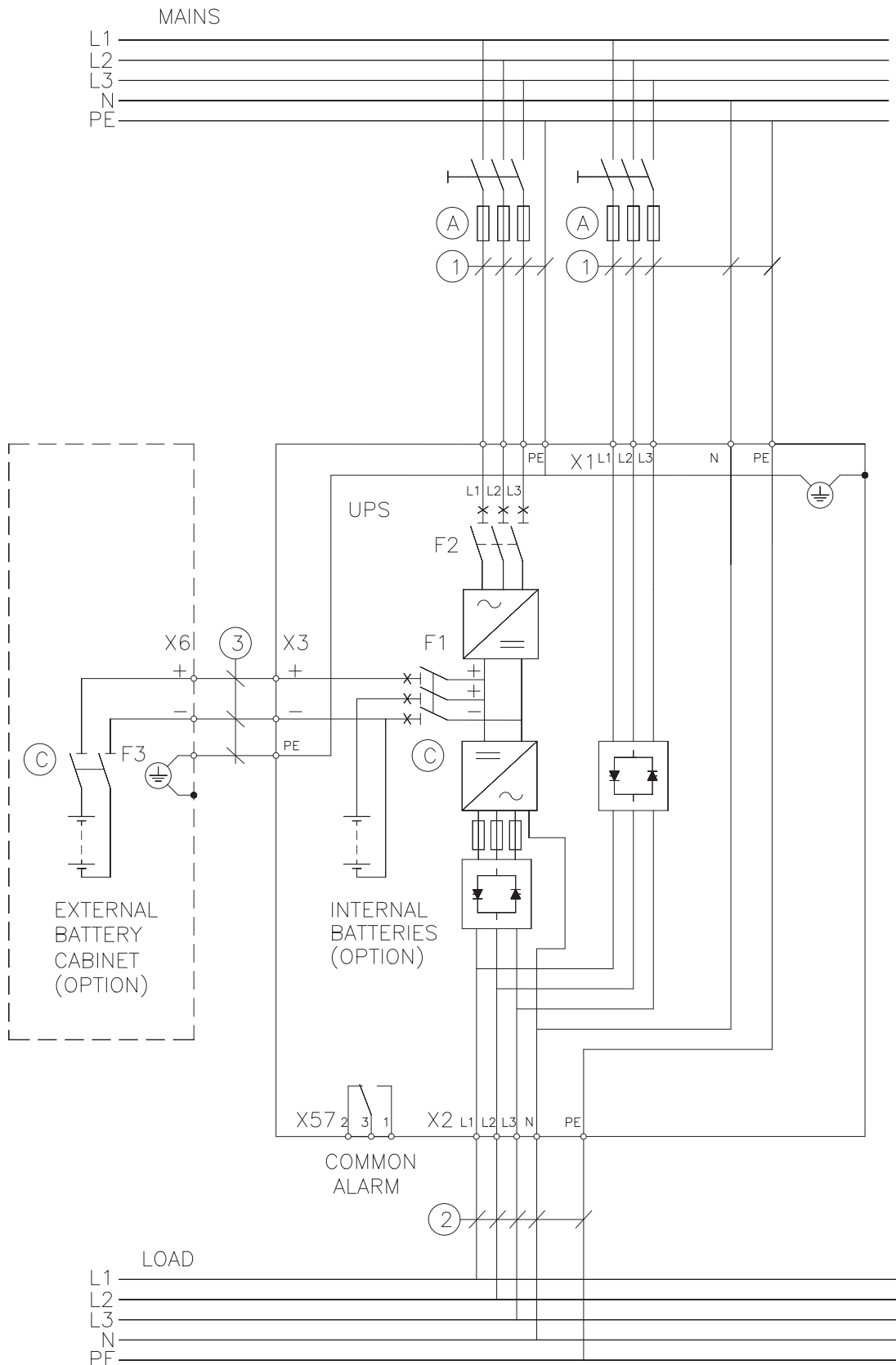

Figure 6-13: Wiring diagram of 9355 N-model (3-phase in / 3-phase out). For cable and fuse sizes, see the Table 6-4.

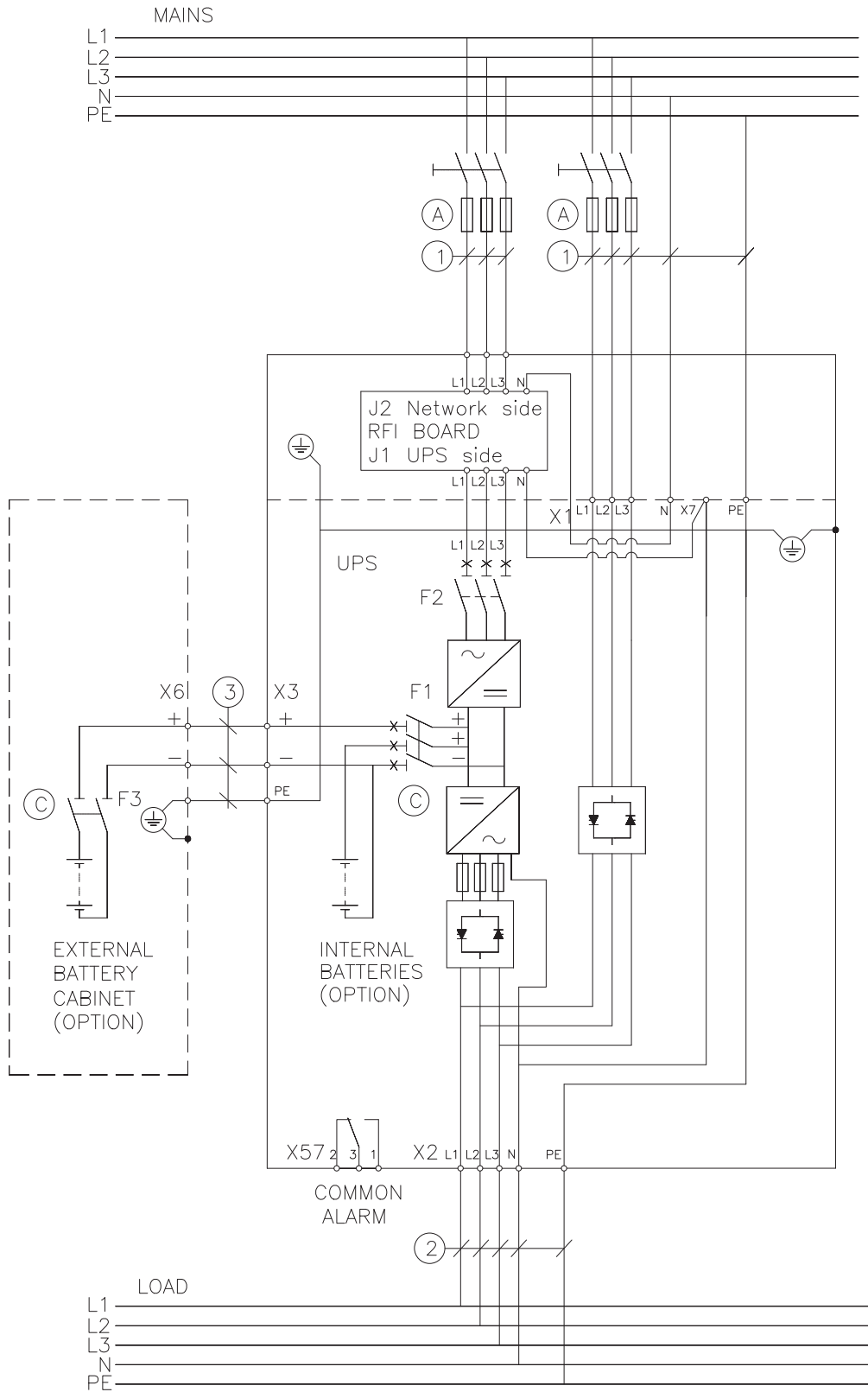

Figure 6-14: Wiring diagram of type approved 9355 N-model (3-phase in / 3-phase out). For cable and fuse sizes, see the Table 6-4.

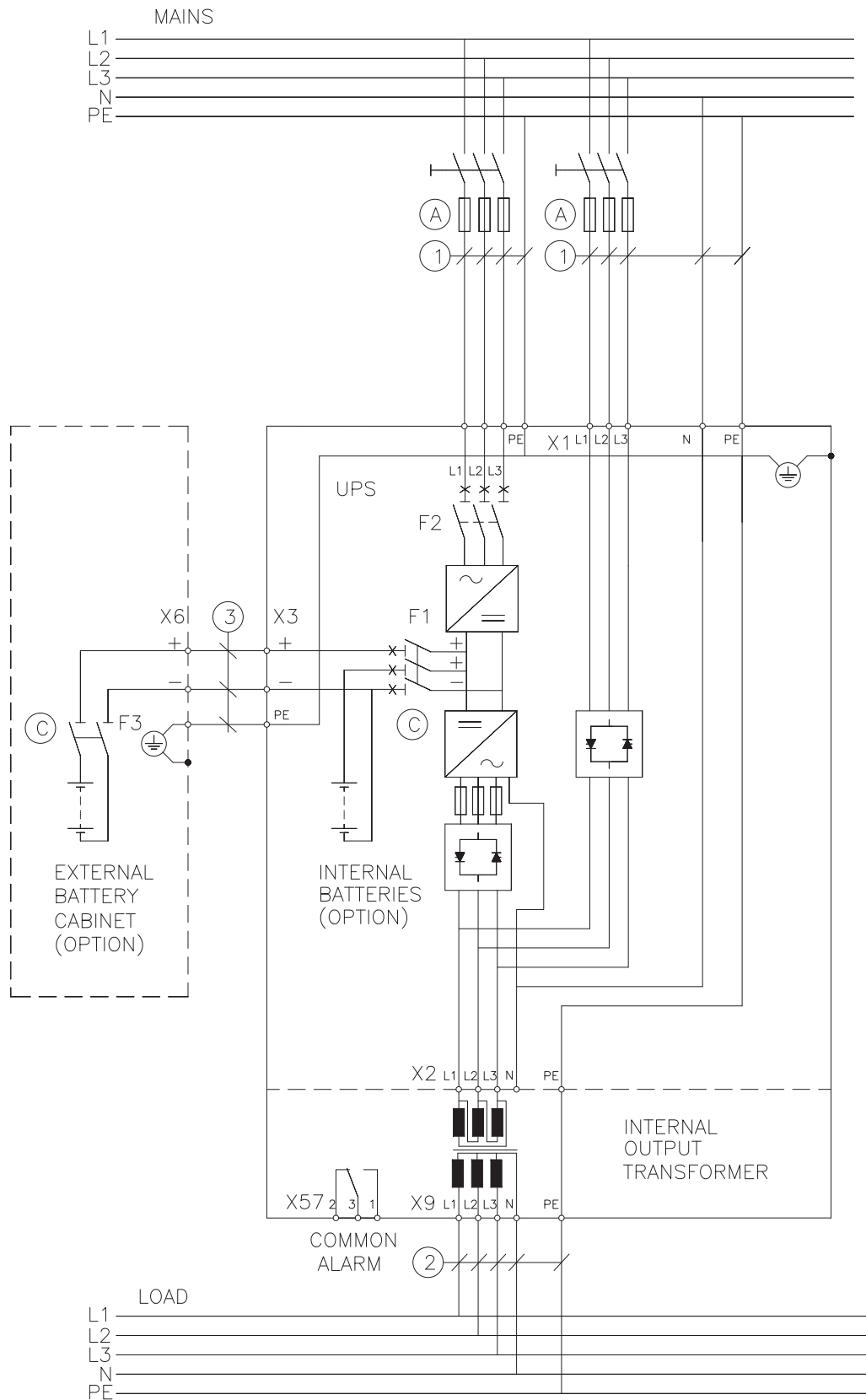

Figure 6-15: Wiring diagram of 9355 NT-model (3-phase in / 3-phase out). For cable and fuse sizes, see the Table 6-4.

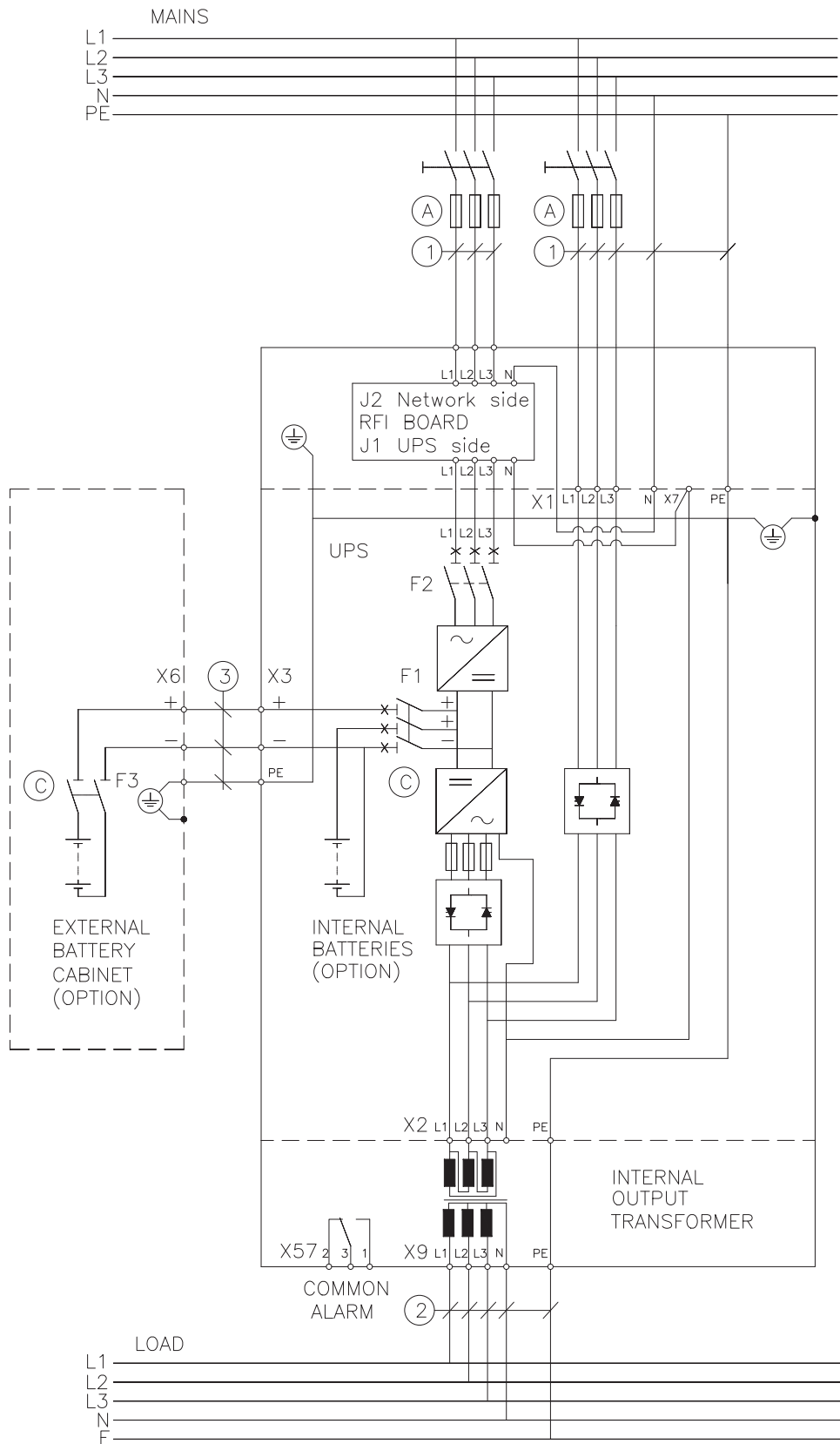

Figure 6-16: Wiring diagram of type approved 9355 NT-model (3-phase in / 3-phase out). For cable and fuse sizes, see the Table 6-4.

9355 (3P in/3P out)	INPUT		PE	BATTERY	
UPS RATING (kVA)	Fusing (FUSE A)	Cabling (CABLE 1)	Cabling (CABLE 1)	Fusing (FUSE A)	Cabling (CABLE 3)
8 kVA	16 A	6 mm ²	6 mm ²	50 A	10 mm ²
10 kVA	20 A	6 mm ²	10 mm ²	50 A	10 mm ²
12 kVA	25 A	6 mm ²	10 mm ²	50 A	10 mm ²
15 kVA	32 A	10 mm ²	10 mm ²	50 A	10 mm ²

9355 (3P in/3P out)	OUTPUT									
UPS RATING (kVA)	Nominal Current with different output voltages					Cabling (CABLE 2) with different output voltages				
	230 V	400 V	440 V	480 V	690 V	230 V	400 V	440 V	480 V	690 V
8 kVA	20,1 A	11,6 A	10,5 A	9,7 A	6,7 A	6 mm ²	2,5 mm ²	2,5 mm ²	2,5 mm ²	2,5 mm ²
10 kVA	25,2 A	14,5 A	13,2 A	12,1 A	8,4 A	10 mm ²	6 mm ²	2,5 mm ²	2,5 mm ²	2,5 mm ²
12 kVA	30,2 A	17,4 A	15,8 A	14,5 A	10,1 A	10 mm ²	6 mm ²	6 mm ²	2,5 mm ²	2,5 mm ²
15 kVA	37,7 A	21,7 A	19,7 A	18,1 A	12,6 A	16 mm ²	10 mm ²	6 mm ²	6 mm ²	6 mm ²

Table 6-4: Recommended cable and fuse sizes for 9355 N-model and 9355 NT-model

6.3 External Battery Cabinet (EBC) installation procedure

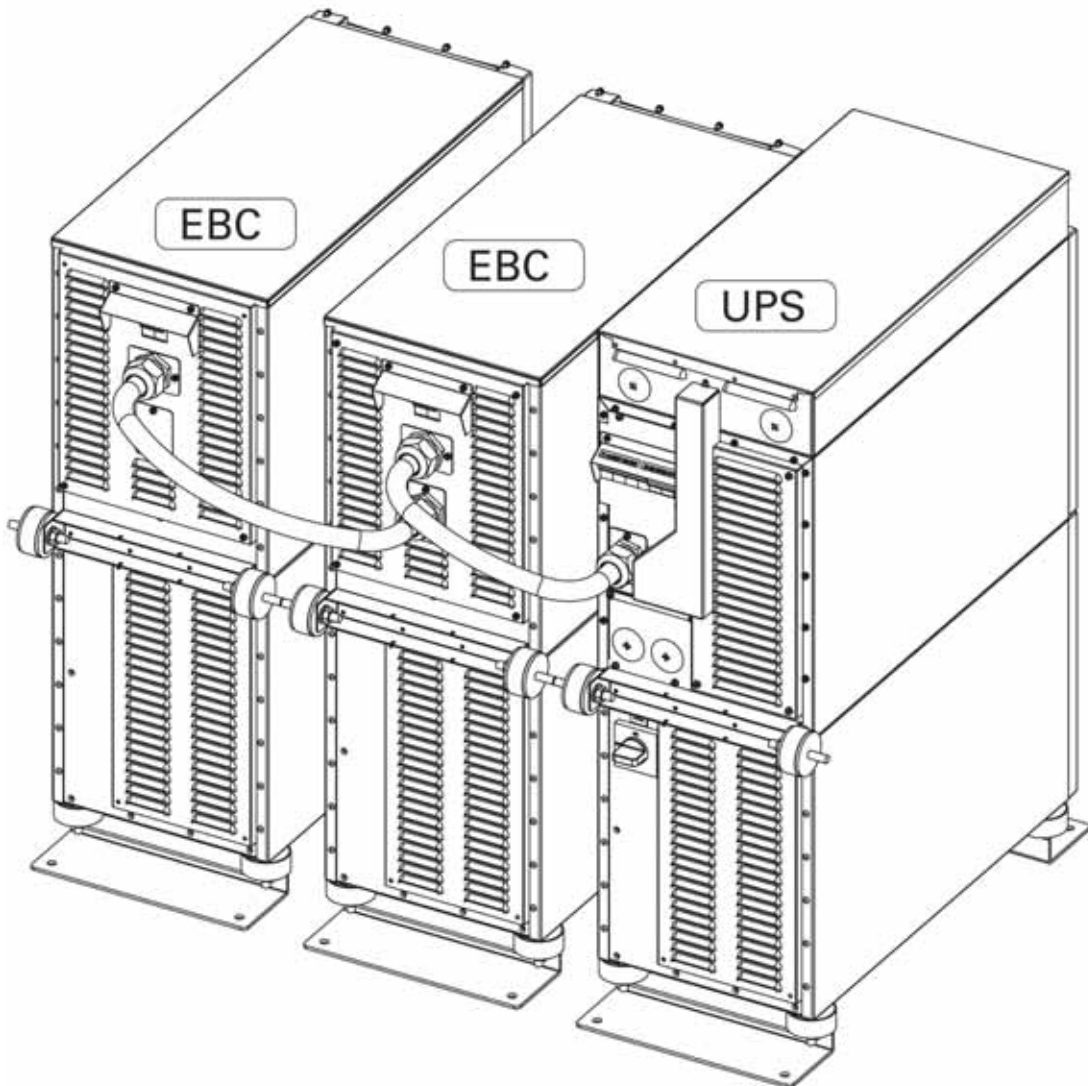

Figure 6-17: Connections of the UPS unit and External Battery Cabinets

The installation procedure is as follows:

1. The EBC is recommended to place next to the UPS unit.



OTE

Do not place EBC on the UPS unit.

2. The required minimum distance for UPS unit and EBC is ten millimetres, which is also required distance between two EBCs.
3. Turn F1 battery breaker from the UPS unit in OFF position.
4. Check that the circuit breaker F3 of the EBC is in the OFF position. To minimise safety risk disconnect one of the cable (+ or -) from battery string to break a battery circuit. Do not remove the safety wire of the circuit breaker before all the wires are connected and the installation of

the whole system is ready. Remove the IP protection plate first and remove the plate A on the rear side of the EBC to connect cables to EBC's terminal block X6. Bring cables outside from the EBC by removing the cover plate B. Place the plate A back to the original position and use the cover plate B as a cable clamp.



WARNING

If an internal battery string is installed and already connected to the terminal block there is a danger of a lethal electric shock. Turn F1 battery breaker from the UPS unit to OFF position and measure the voltage across the terminals to be 0 (zero) before any operations with terminal X3.

5. If the system consists two or more EBC connect first the EBCs parallel as follows:
 - a) Connect the cables to second EBC in the same way as guided in point four (4) of this installation procedure.
 - b) Remove the cover plate C of the first EBC and connect cables to terminal block X6. Use the cover plate C as a cable clamp.
6. When all the EBCs are connected parallel, make sure that F1 battery breaker is in OFF position before connecting cables to terminal block X3 of the UPS unit. Otherwise the terminal block X3 is live. To be on the safe side, measure the voltage across the terminals to be 0 (zero).
7. After installation connect disconnected battery cables to strings, check that the removed plates on right positions, remove safety wires from circuit breakers and turn breakers of EBCs and the UPS to ON position.
8. Finally change the Number of 32 pcs. battery strings from User Settings. SETTINGS -> USER SETTINGS -> NUMBER OF BATTERY STRINGS.

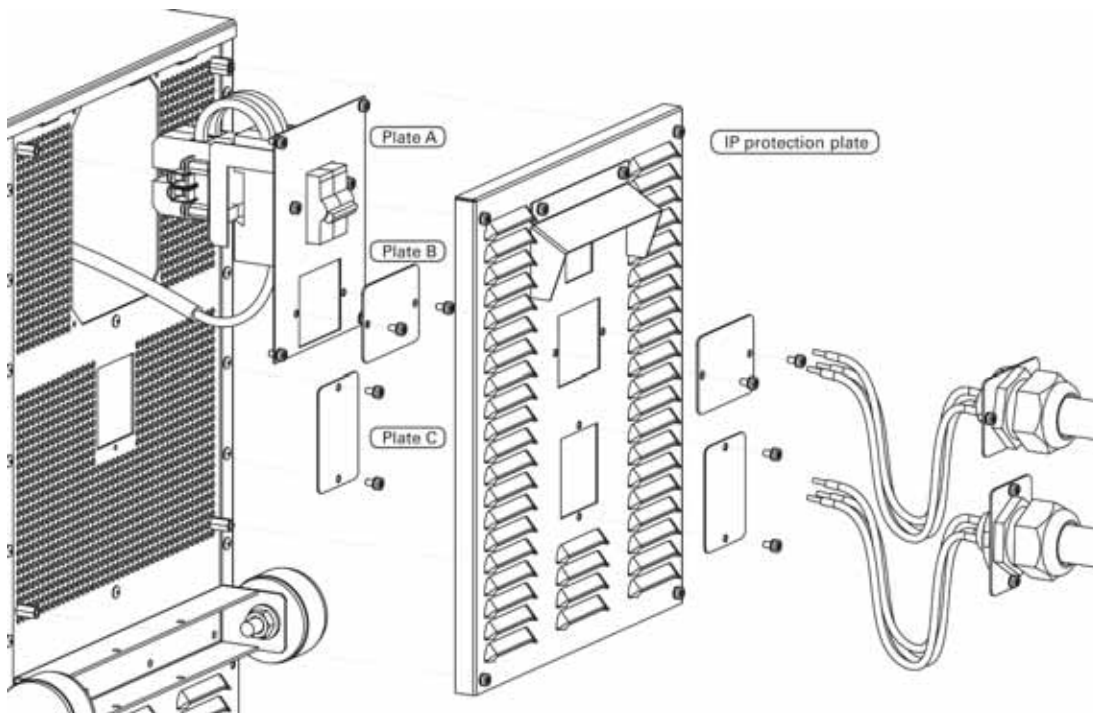

Figure 6-18: Cable connections of the External Battery Cabinet

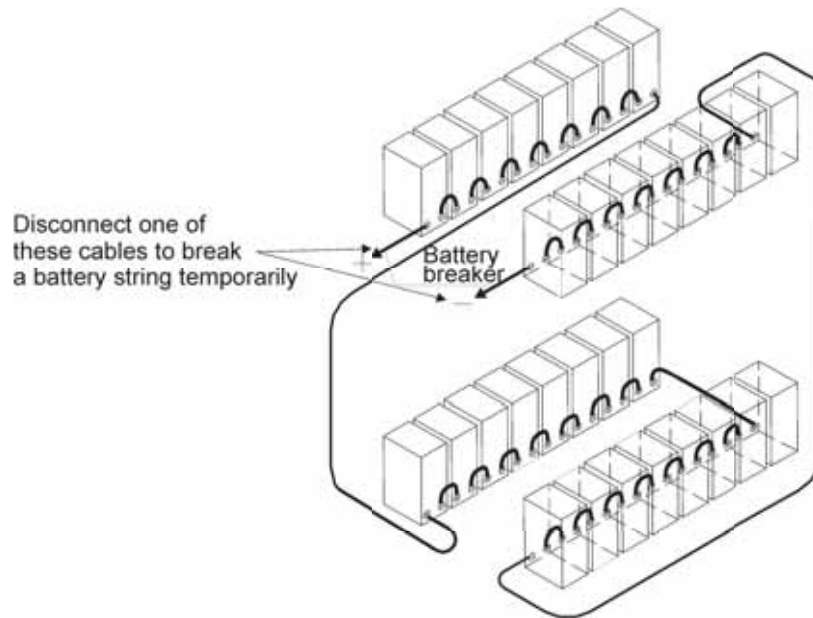

Figure 6-19: To minimise safety risk remove + or - cable from battery string before connecting UPS and EBCs

7 Software and connectivity

The software Suite CD-ROM that is bundled with the UPS contains software distributions and documentation in CD format. Furthermore, the comprehensive connectivity option portfolio includes Web/SNMP adapters for networked environments, Modem card for 24/7 remote monitoring, ModBus/Jbus card for building management system integration, relay interface cards for industrial and facilities use and RS-232 cards for serial communication to one or multiple computers.

7.1 Communication cables

It is recommended that the control cables and power cables be installed on separate trays. Where control cables will cross power cables make sure they are arranged at an angle as near to 90 degrees as possible.

All control cables shall preferably be shielded. If the shield is grounded, this shall take place on only one end of the cable.

The procedure for connecting the control cables is the following:

1. Remove the front cover by lifting the cover from the bottom upwards by releasing the retaining clip. It's located in the bottom part of the bezel.
2. Locate the control terminal or XSlot module where you want to install the communications cable.

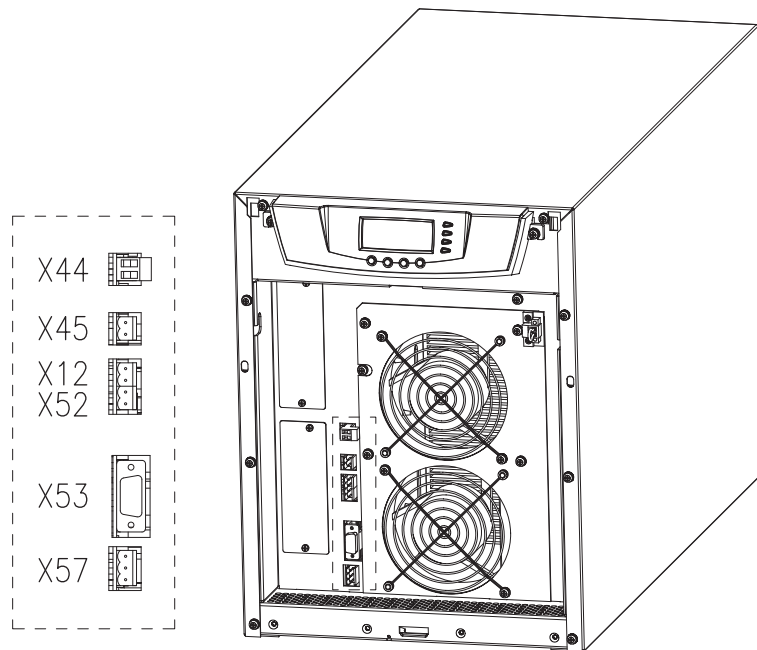

Figure 7-1: Location of control cable terminals: Signal inputs (X44 & X45); EPO (NC (X12) & NO (X52)); RS-232 (X53); Relay output (X57)

7.2 Connection to the standard RS-232 port (X53)

The standard RS-232 interface uses 9-pin female D-sub connector. It shall be used with the delivered cable for a computer or external modem connection. The data is transmitted with XCP protocol that includes status and meters information about the UPS. The RS-232 port has the following format:

- Communication speed 19200 bps*
- Data bits 8
- Parity None
- Stop bits 1
- Handshake None

*Communication speed can be changed via LCD menu.

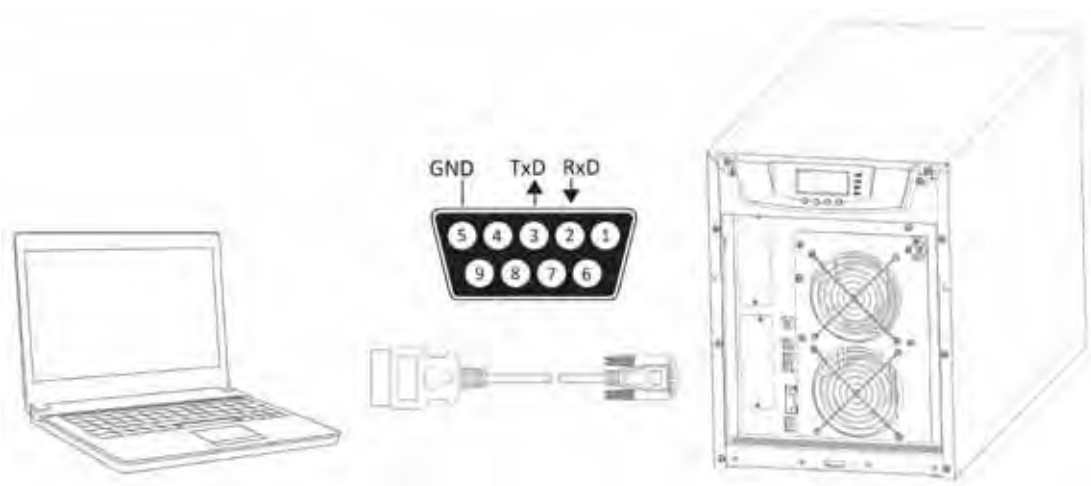

Figure 7-2: Identification of the interface port pins

7.2.1 LanSafe software

The LanSafe software shuts down computers and whole networks in case of an extended power failure. It provides basic monitoring, data logging, notification and event actions for a single UPS solution. The software is bundled free of charge in Software Suite CD.

The connection procedure for the RS-232 interface port is following:

1. Connect the RS-232 communication cable to the computer.
2. Connect the RS-232 communication cable to the serial interface on the UPS.
3. Run the UPS software installation disk (Software Suite CD) on the computer.



OTE

If communication does not work choose the correct communication speed from the LCD menu, then refer to the optional software manuals for appropriate bit rate settings.

7.3 External control connections

The UPS has an input/output interface for direct communication with your computer system. It is located behind the front bezel of the UPS unit. The cables connected to these terminals should be connected to cable clips.

Input and output terminals have a functional isolation from terminal to terminal. They are connected to the chassis through individual 1 MΩ resistors.

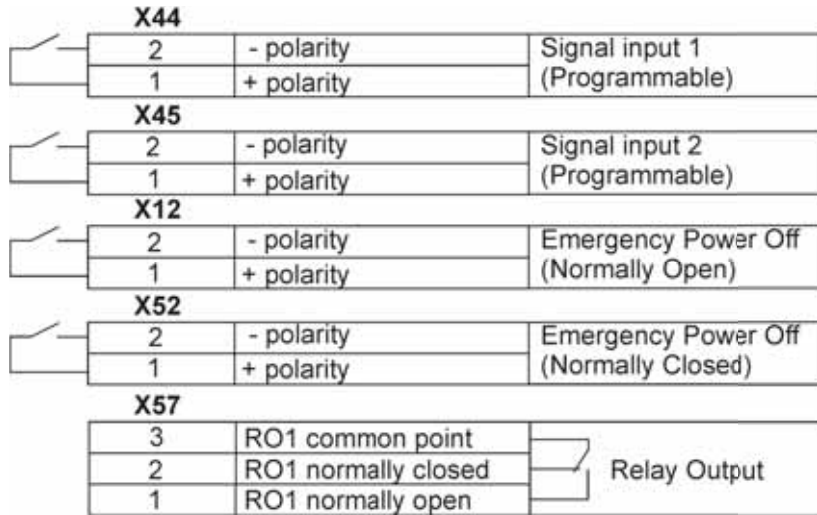

Figure 7-3: External control cable connections to the UPS



OTE

Pay attention to proper polarity if one is using a semiconductor switch type. A relay or other mechanical control is a preferred method.

7.3.1 Emergency Power Off (EPO)

EPO is used to shut down the UPS from a distance. This feature is intended for an emergency power down. There are two different modes of operation that can be used: normally closed (NC) contacts at X52 and normally open (NO) contacts at X12. Pins 1 and 2 at the remote shut down terminal X52 are as factory default closed. When the contacts at X52 are opened, the UPS output will be immediately shut down and the battery breaker (F1) opened. The Emergency Power Off circuit is powered by the UPS unit's internal auxiliary power. Do not apply power from external source to terminals X52 or X12.



OTE

EPO does not necessarily disconnect supply to load when unit is on internal or external bypass. Guaranteed disconnection of bypass supply has to be through a separate disconnect switch located in the supplying switchgear cabinet.

In order to have the UPS running again pins 1 and 2 of connector X52 have to be reconnected and the UPS started manually. The pins must be shorted in order to keep the UPS running. Maximum resistance is 10 ohm. The EPO shall not be galvanically connected to any mains connected circuits. Reinforced insulation to the mains is required. See also *Chapter 8.5 Start-up after EPO* on page 56.

If the use of normally open EPO operation is desired, the loop on X52 has to be retained and the normally open EPO switch connected to X12. Operation is as above.

7.3.2 Relay outputs

The UPS incorporates a programmable relay output with potential free contacts at X57 for remote alarm indications. It is rated for max. 30 VAC 1 A or 60 VDC 0,2 A nominal values. Additional (4) relay outputs can be obtained with the XSlot compatible AS/400 Relay Module (optional). For more information see *Chapter 8.2.4 Using relay outputs* on page 54.



WARNING

The relay contacts must not be directly connected to mains related circuits. Reinforced insulation to the mains is required.

7.3.3 Programmable signal inputs

The UPS incorporates two programmable inputs (X44, X45). Use of a non-polar (relay) control input is recommended. The pins must be shorted with maximum resistance of 10 ohm in order to activate the specific input.



OTE

Please note the polarity of the inputs as indicated in the external control connections if used with a polarity control.

The default and programmable settings for the signal inputs are:

- **Disable Bypass Operation** (If active the automatic transfer to the static bypass is prevented.)
- **Charger off** (If active the batteries charging is disabled. In case of mains power outage the discharge of batteries is supported.)
- **Remote ON/OFF** (If active the UPS output turns off regardless of mode of operation. Auxiliary power, fan, communications and rectifier/battery charger shall remain functional. Restart initiated immediately when inactive.)
- **Request Bypass** (If active the UPS transfers to bypass if bypass voltage, frequency, and synchronisation are ok.)
- **Request Normal** (If active the UPS transfers to inverter operation if not prohibited by EPO or alarm condition.)
- **Force Bypass** (If active the UPS is forced to static bypass operation regardless of the bypass status.)
- **External Battery Breaker Status** (If active the UPS knows that the batteries are disconnected.)

- **Building alarm 1-6** (These can be activated separately or at the same time with other building alarms.)
- **ot in use (default)**
- **Shutdown** (If active the UPS will shutdown immediately.)
- **Delayed Shutdown** (If active the UPS will shutdown after user configurable delay time. Restart initiated immediately when inactive.)
- **ormal/Bypass** (If active the UPS transfers to bypass if ok. If inactive the UPS transfers to inverter when possible.)
- **Output transformer over temperature** (If active the UPS output turns off after user configurable delay time.)
- **Input transformer over temperature without bypass** (If active the UPS will start to operate on battery or shutdown when batteries not available after one minute delay.)
- **Input transformer over temperature with bypass** (If active the UPS will start to operate on battery or transfer to bypass after one minute delay.)

7.3.4 EPO relay (option)

The Emergency Power Off (EPO) is a safety feature designed to power down the UPS in case of an emergency. The EPO relay is activated when control voltage (24VDC) is applied to it. The logic circuit will receive the signal and immediately turn off the output power of the UPS and open the battery circuit breaker (F1) disconnecting the battery power. After using EPO, the UPS unit needs to be started manually. The EPO relay can be ordered as factory installed.

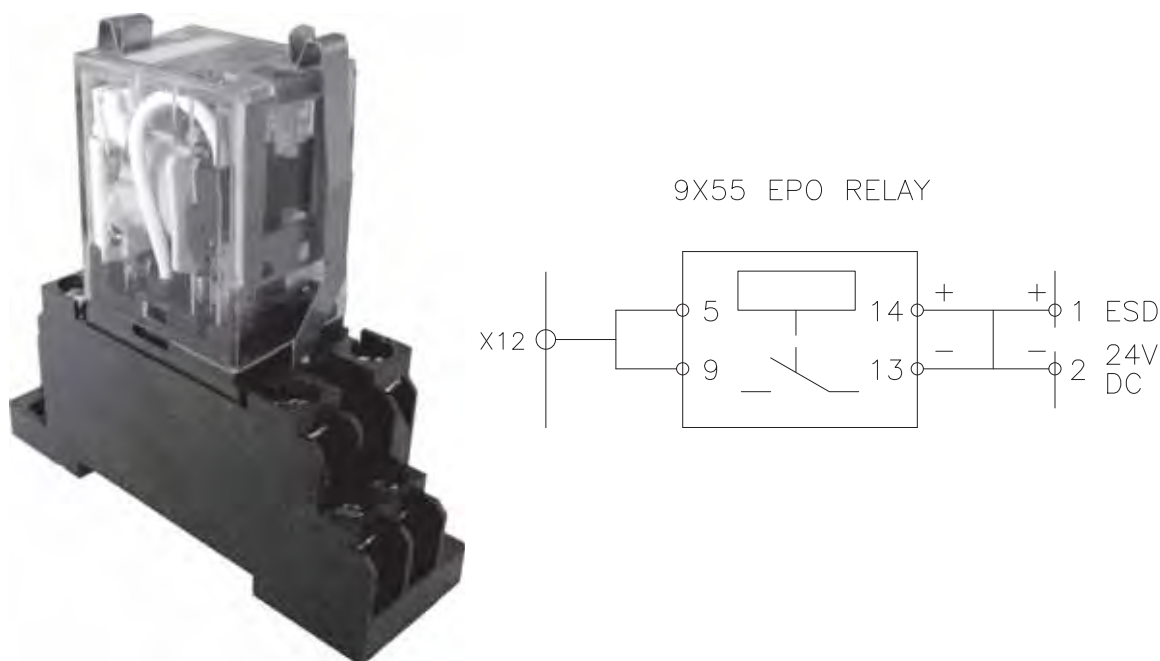

Figure 7-4: EPO relay and the connection diagram

7.3.5 Earth fault monitor (option)

The earth fault monitor is used to detect earth fault in UPS by monitoring the system's insulation resistance. The device is connected to the supply via terminals A1-A2. Terminal L is connected to the monitored voltage and PE terminal is connected to earth.

If the insulation resistance drops below the adjusted alarm value, the red LED goes on and the output relay switches off. The earth fault monitor is in auto reset mode when a bridge between terminals LT1 and LT2 is connected. Now the output relay switches back on if the insulation resistance gets back to normal. Without the auto reset mode on, the insulation monitor remains in faulty state even when the insulation resistance gets back to normal and the reset needs to be done manually by pressing the reset button.

When the UPS is equipped with an internal Maintenance Bypass Switch (MBS), the control input X45 is reserved for the status information from the MBS. In this case the earth fault signal shall be taken straight from the terminals 11 and 14 of the earth fault monitor.

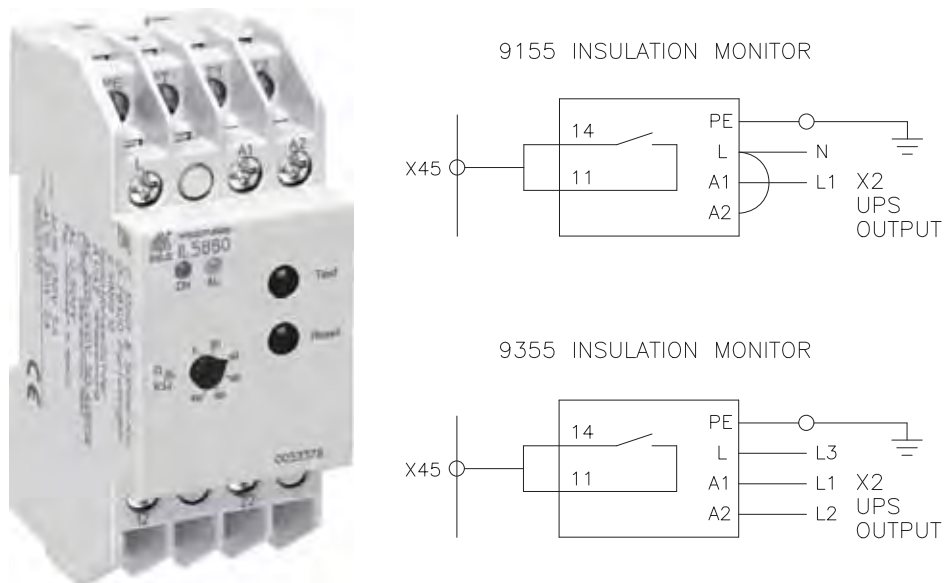

Figure 7-5: Earth fault monitor and the connection diagrams for 9155 and 9355 models

7.4 XSlot communication (option)

XSlot modules allow the UPS to communicate in a variety of networking environments and with different types of devices. The UPS incorporates two (2) empty XSlot communication bays.

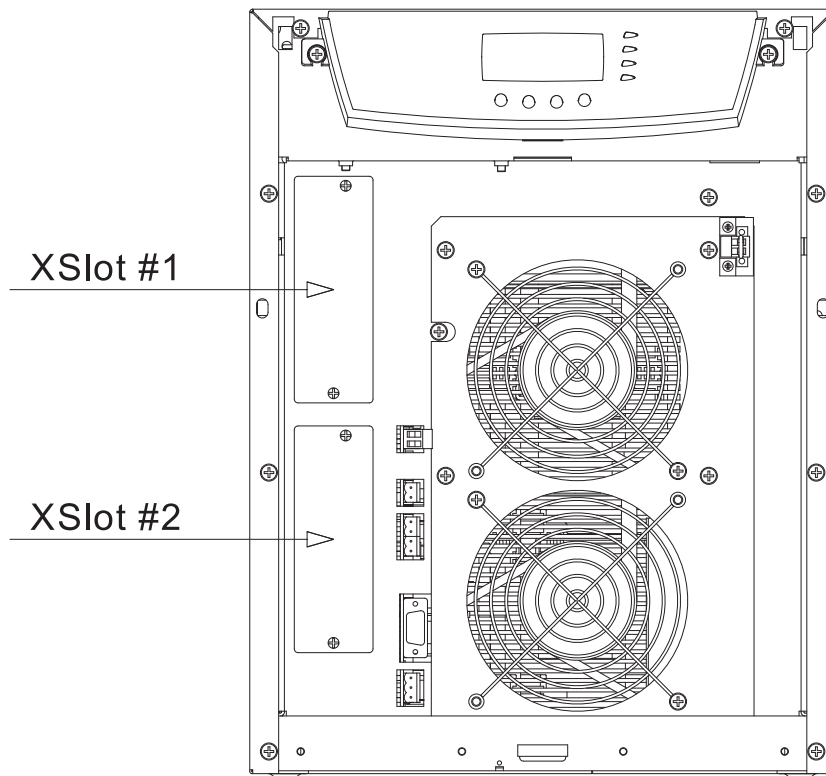

Figure 7-6: Location of empty XSlot bays

The UPS supports two serial communication devices according to the table below.

	Independent	Multiplexed	
Configuration	XSlot #1	XSlot #2	Std. RS-232 port
Default #1	Any Xslot module	Any Xslot module	Not in use
Default #2	Any Xslot module	Relay module	Available
Default #3	Any Xslot module	Not in use	Available

Table 7-1: Typical XSlot configurations for UPS communication

7.4.1 Web/SNMP Module (optional)

The module supports SNMP and HTTP compliant remote monitoring and shutdown for the protected computer systems. It can be connected to a twisted-pair Ethernet network (10/100BaseT) using an RJ45 connector.

The Web/SNMP module has a build-in switching hub that allows three (3) additional network devices to be connected to the network without the requirement of additional network drops. In addition, an Environmental Monitoring Probe can be requested from the UPS manufacturer to obtain humidity, temperature, smoke alarm and security information. It is connected to the communication port of the Web/SNMP module as option.

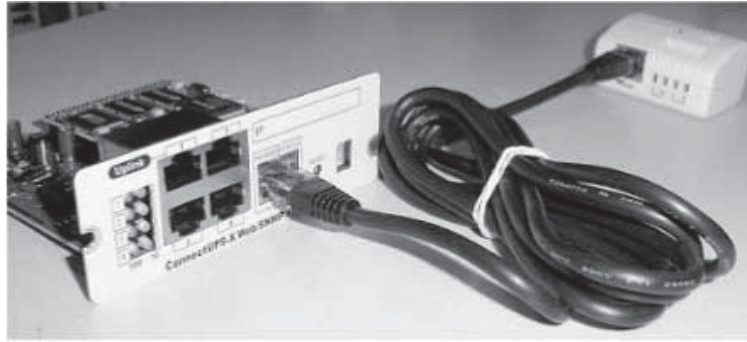

Figure 7-7: ConnectUPS-X Web/SNMP Module and Environmental Monitoring Probe

7.4.2 AS400 Relay Module (optional)

The Relay Module provides potential free relay interface for AS/400 connected computers and industrial applications. The relay interface supports both 15-pin D-sub connector and terminal block connections up to four (4) potential free relays.

The relay contacts are rated for 1 A, 30 Vac or 200 mA, 60 Vdc, and they have a galvanic isolation from the other circuits of the UPS unit.

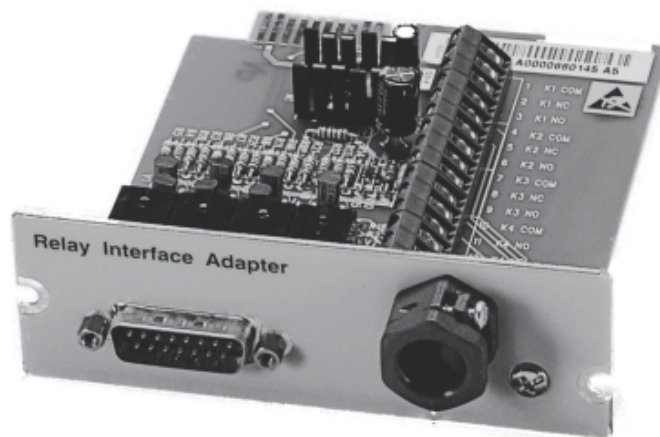

Figure 7-8: AS400 Relay Module

7.4.3 Single Serial Port Module (optional)

To establish communication between the UPS and a computer, connect your computer to the UPS communication port using the supplied communication cable.

When the communication cable is installed, power management software can exchange data with the UPS. The software polls the UPS for detailed information on the status of the power environment. If a power emergency occurs, the software initiates the saving of all data and an orderly shutdown of the equipment.

7.4.4 Modbus/Jbus Module (optional)

The Modbus module provides monitoring and integration to the Building Management Software (BMS) such as Wonderware. It features continuous and reliable communication through isolated DB9 ports (RS485/RS232) or a terminal strip (RS485).



Figure 7-9: Modbus/Jbus Module

8 User operations

The UPS has a four-button graphical LCD with backlight. It provides useful information about the unit itself, load status, events, measurements, and settings.

The LCD backlight is switched on by pressing any button. It has a timeout that automatically switches off after 15 minutes of inactivity.

8.1 Display functions

As default and after 15 minutes of inactivity the UPS is showing the selectable start screen:

1. Logo screen
2. Mimic screen (See *Chapter 8.2 User settings* on page 50.)

The screen backlit has automatic shutdown after long period of inactivity. It will light up once a button is pushed. The right side button will initiate the text to the screen. The scrolling through the menu structure is done with buttons indicated by the ↑ ↓ images of the LCD screen. The menu structure is shown in the table below. There are small differences in the menu structure between single and parallel mode.

Parallel Mode	Single Mode	Main Menu	Submenu	Menu functions
x	x	UPS STATUS	->	UPS off / System normal / UPS supporting load / UPS on battery / UPS on bypass / +active alarms and notices / +battery status (resting, charging, floating, not connected, discharging)
x	x	EVENT LOG	->	Notice / Alarm
x	x	MEASUREMENTS	PARALLEL SYSTEM	Parallel unit 1...4 kW/Parallel total kW
			OUTPUT	Voltage / Current / Frequency / Power
			BATTERY	Voltage / Current / Runtime
			INPUT	Voltage / Current / Frequency
			BYPASS	Voltage / Frequency

Parallel Mode	Single Mode	Main Menu	Submenu	Menu functions
x	x	CONTROL	->	Goto bypass / Battery test/ Display test / Reset error state
x	x	SETTINGS	USER SET-TINGS	Date / LCD contrast / Change language / Relay config / Signal inputs / Serial port config / Parallel operation settings / Start screen / User password / Audible alarms / Battery charging method / +list of std. settings
			SERVICE SETTINGS	Adjust parameters / Adjust events / Reset custom / Clear history / + modem call settings
x	x	IDENTIFICATION	->	UPS Type / Part nro. / Serial nro / Revisions
	x	TURN UPS ON	->	-
	x	TURN UPS OFF		
x		TURN SYSTEM ON		
x		TURN UPS OFF		
x		TURN SYSTEM OFF		

Table 8-1: Menu map for display functions

8.2 User settings

The UPS has the following typical settings that are user configurable. Note that some of the settings become effective at the next start-up of the UPS. User settings can be configured via LCD menu. Select SETTINGS -> USER SETTINGS.

Description	available settings	Default setting
General:		
Display contrast adjustment	+ / -	Moderate
Display language	[English], [Spanish], [French], [German]	English (British)
Date & Time	[xxxx-xx-xx]	0001-01-01
Audible alarms	[Normal], [Disabled]	Normal
Normal screen in display	[logo], [mimic]	Product name
User settings password	[Not required], [Set]	Not required
nominal values:		
Nominal output voltage (L-N)	[220], [230], [240]	230 Volts
Nominal output frequency	[50 Hz], [60 Hz]	50 Hz
Rectifier phase current limit	Step: 1 A	32 A
Communication and connectivity:		
Disable control commands	[Enabled], [Disabled]	Disabled
Communication speed	[1200], [2400], [9600], [19200]	19200 bps.
Std. relay output function	[UPS ON/OK], [Custom], [Battery low], [System on bypass], [System on battery]	UPS ON/OK
Signal input #1-2 function	[Empty], [see <i>Chapter 7.3.3 Programmable signal inputs</i> on page 43.]	Empty
Hardware remote off delay for hardware Remote off with restart function.	Step: 1 sec.	120 sec.
XSlot relay output 1-4 function	[Nothing], [see <i>Chapter 8.2.4 Using relay outputs</i> on page 54.]	XSlot defaults: #1: on battery #2: battery low #3: UPS on/ok #4: on bypass

Description	available settings	Default setting
XSlot input signal (long break via Rx)		Nothing
XSlot shutdown signal activation delay before the signal is accepted.	Step: 1 sec.	5 sec.
Bypass and synchronisation:		
Usage of bypass	[Enabled], [Disabled]	Enabled
Require synch at transfer on bypass	[Required], [Not Required]	Not required
Transfer on bypass on overload	[Immediately], [after delay]	Immediately
Synchronization enable	[Enabled], [Disabled]	Enabled
Bypass voltage deviation high limit	+1% ... +20%, step: 1%	+10%
Bypass voltage deviation low limit	-1% ... -20%, step: 1%	-15%
Synchronization window	0.5 ... 3.0 Hz, step: 0.1 Hz	±2.0 Hz
Frequency slew rate (not in parallel mode)	0.1 ... 3.0 Hz/s, step 0.1 Hz/s	0.2 Hz/s
Battery information and settings:		
ABM charging cycling disable	[Enabled], [Disabled]	Enabled
Charging temp compensation	[Enabled], [Disabled]	Enabled
Battery size setting	Step: 1 Watts/cell	24 Watts/cell
Number of 36 pcs. battery strings	0 (no batteries), 1, 2, 3, 4...	1 string
Battery low alarm level	Step: 0.01 V/cell	1.88 V/cell
Automatic battery support test	[Enabled], [Disabled]	Enabled
Maximum charging current	Step: 0.1 A [max. 25 Amps]	3 A
Output on, automatic delay time before turning the output on	[Disabled], [Set delay, step: 1 sec]	0 sec.
Output off, automatic delay time on battery after which output is turned off	[Disabled], [Set delay, step: 1 sec]	Disabled
User preferences:		

Description	available settings	Default setting
Operation priority while rectifier input break	[On battery], [On bypass]	On battery
Site wiring fault w/ wrong Neutral connection	[Enabled], [Disabled]	Disabled
Power Strategy	[Standard], [High Efficiency]	Standard
Parallel settings:		
Parallel unit number	[Single unit], [Unit #1], [Unit #2], [Unit #3], [Unit #4]	Single unit
Parallel operation mode	[Redundant mode], [Capacity mode]	Redundant mode
Synchronization	[Enabled], [Disabled]	Enabled
Start auto calibration		
Parallel XCP	[System], [Unit]	System
Minimum units to support load	[0], [1], [2], [3], [4]	2

Table 8-2: User setting in the LCD menu screen

8.2.1 Configuring user settings

User settings can be configured via front panel. Select Settings from main menu and then select User Settings.

8.2.2 Changing language

Pressing and holding down the first button on the left for about 3 seconds selects the language menu. This action is possible from any LCD menu screen.

The default firmware has four main languages: English, Spanish, French and German. Other local language packages including Chinese, Greek and Russian can be requested from the local service representative.

8.2.3 Changing charging current

Maximum charging current setting should be checked when needed back-up time needs more than 3 Amps charging current.

Load (kVA) p.f. 0.7	Back-up time	Min current	Load (kVA) p.f. 0.7	Back-up time	Min current
10	1 h	1.8 A	15	1 h	2.5 A
10	3 h	4 A	15	3 h	6.5 A

Load (kVA) p.f. 0.7	Back-up time	Min current	Load (kVA) p.f. 0.7	Back-up time	Min current
10	5 h	6.5 A	15	5 h	9 A
10	10 h	13 A	15	10 h	18 A

Table 8-3: Required battery charge currents

Select Maximum charging current from User Settings menu. Default setting is 3.0 Amps and it is changeable up to 20 Amps. Minimum step is 0.1 A.



O**T****E**

Maximum charging current is dependent on output load and power rate of the UPS. If the UPS is supporting maximum output load the highest level of Maximum charging current is 3.0 A, which is also the default setting. As a thumb rule, 1 kW decrease in the load provides extra 2.0 A charging capacity. For example, the charging capacity is 5 Amps at 8 kW load, and 7 A at 7 kW load.

8.2.4 Using relay outputs

Relay outputs can be used for remote alarm indications.

Each relay has four standard pre-programmed settings for alarms:

- **on bypass**
- **UPS ok**
- **battery low**
- **on battery**

One of the standard relay settings is "custom" that can be customised by the user.

The procedure to select customised alarms:

1. Push any key of the control panel to enable the functions on the LCD screen.
2. First select "SETTINGS", then "USER SETTINGS" and finally "RELAY CONFIG" from the LCD menu.
3. Select the relay what is needed to be configured (ALARM-1 is fixed relay output X57).
4. Select "empty" to clear old settings.
5. Select "custom" and activate needed alarms with the button on the right.
6. After the selection press the "OK" button.
7. Finally test that UPS alarms correctly.

8.3 Normal start-up

Check the mechanical and electrical installation of the UPS before start-up.

Go through the checklist below together with another person.

Check:

- Read the attached safety manual before you work on the unit.
- The unit is fixed according to mechanical installation.
- The ambient conditions are within specification.
- The cooling air will flow freely.
- The UPS is grounded properly.
- The input and bypass voltages match the UPS nominal voltage.
- The input, bypass, battery and output terminal connections are OK.
- Appropriate input and bypass fuses and disconnectors are installed.
- Appropriate backfeed warning sign for disconnectors are installed.
- Appropriate cables sizes are used.
- The external control connections inside the UPS are OK.
- There are no tools, foreign objects or dust inside the UPS from the installation.
- Covers are in place.
- Optional MBS is placed to UPS position as default.

You are then ready to proceed with the starting up the UPS:

1. Turn the battery and input circuit breakers to ON position.
2. UPS will enter a stand-by mode and starts to charge batteries with a cooling fan operational. Output is without the voltage in the stand-by mode.
3. Push any key of the control panel to enable the functions of the LCD screen.
4. Select "TURN UPS ON" from the LCD menu (see *Chapter 8.1 Display functions* on page 49).
5. Press and hold the return  button for 2 sec. There shall be no sound during the hold.

The UPS shall check its internal functions, synchronise to bypass and start to supply the load. The green LED is blinking if there occurs an active notice. In normal operation the green LED is constantly lit if no new active notice such as 'unsynchronised' or similar notices present.

The output voltage shall be verified from the output measurements screen of the LCD. If there is voltage in the output then UPS is supplying the load.

8.4 Battery start-up

UPS will start on battery if mains is not available. Note that the UPS behavior may be slightly different from the normal start-ups.

8.5 Start-up after EPO

1. Find out the reason that caused EPO.
2. Check that there are no risk to start the UPS again.
3. Follow Normal start-up check list and procedure.

8.6 Shutdown

The procedure to shutdown from LCD is following:

1. Push any key of the control panel to enable the functions of the LCD screen.
2. Select "TURN UPS OFF" from the LCD menu (see *Chapter 8.1 Display functions* on page 49).
3. Press and hold the return  button for 5 sec. There shall be an indication sound during the hold.
4. UPS shall do a shutdown routine.
5. Turn the battery and input circuit breakers to OFF position to finalise the shutdown procedure.



OTE

The behaviour is different if UPS is turned off from the programmable input or through communication cards. If battery and input circuit breakers are left ON, UPS will enter a stand-by mode and starts to charge batteries with a cooling fan operational. Output is without the voltage in the stand-by mode.

9 Maintenance

All operations inside the unit must be performed only by a service engineer from the manufacturer or from an agent, authorised by the manufacturer.

The troubleshooting procedure gives simple remedial if a malfunction occurs in the UPS. The operator should start the trouble shooting if there is an active alarm indicated on the LCD screen. Service should be contacted if the active alarm is abnormal and displayed as a service code.

Call service if you are not able to solve the problem.

LDC display	Description	Action
Overload	The connected load needs more power than the UPS is rated to provide. The inverter or static bypass is supplying the excessive load level.	Shut down the least important load that is connected to the UPS. The UPS should switch back to normal operation once the load level is acceptable.
Battery test failed	Your batteries are detected to be faulty.	Batteries should be replaced and you need to contact the local office or representative of the UPS manufacturer.
Battery low	The UPS is operating in stored energy mode. It will shut down soon due to low battery voltage.	Make controlled shutdown of the protected load immediately to prevent loss of data.
On battery	The UPS is operating in stored energy mode.	Save your data and perform a controlled shutdown of your server load.
Overtemperature	High UPS temperature is detected.	Check that fans are operational and ventilation holes are not blocked. Make sure the ambient temperature is not excessive.

Table 9-1: Typical alarms displayed in the LCD screen of the UPS unit

9.1 Regular service/intervals

The UPS requires very little maintenance if installed in an appropriate environment. In order to ensure maximum availability of the UPS, manufacturer recommends signing a proactive service agreement with a local authorised service provider.

Maintenance	Interval
Batteries change	~ 3-5 years / service
Batteries test	~ 18 months / service

Maintenance	Interval
Cooling fan change	~ 5 years / service

Table 9-2: Routine maintenance intervals recommended by the manufacturer

9.1.1 Batteries

The condition of the batteries is crucial for operation. The UPS will indicate by audible and visual alarms if the capacity of the battery bank has decreased. The UPS units are provided with the automatic battery test and ABM management function to continuously monitor the condition of the battery bank.

Servicing of batteries should be performed or supervised by personnel knowledgeable about batteries and required precautions. When replacing batteries, replace with the same type and number of batteries.



OTE

Do not dispose of batteries in a fire. The batteries may explode. Do not open or mutilate batteries. Released electrolyte is harmful to the skin and eyes. It may be toxic.



CAUTION

RISK OF EXPLOSION IF BATTERY IS REPLACED BY AN INCORRECTED TYPE. DISPOSE OF USED BATTERIES ACCORDING TO THE INSTRUCTIONS.

9.1.2 Cooling fan

The cooling fan lifespan of the UPS unit is about 60 000 operating hours. The actual lifespan depends on the environment and ambient temperature.

Fan failure can be predicted by increasing noise from the fan bearings. The fan replacement is recommended once this symptom starts appearing.

Do not use other than manufacturer's specified spare parts.

9.2 LED indicators

The UPS unit has (4) LEDs to indicate the status.

Graphical sign	LED	Description	ote
	Green	UPS status is OK.	Blinking when a new notice message is active.



Graphical sign	LED	Description	ote
	Yellow 1	UPS is in battery mode.	
	Yellow 2	UPS is in bypass mode.	
	Red	UPS has an active alarm.	Blinking when new alarm is not reset and still active.

Table 9-3: Description of the LED indicators

9.3 Maintenance bypass switch (MBS) operation

The UPS unit comes with a maintenance bypass switch as a standard or optional feature, depending on the ordered configuration. The operation of the MBS is allowed for a trained person only who is familiar with the UPS behavior and functions. The full UPS wiring diagram with a MBS switch is presented in the installation part of the manual.

9.3.1 Internal maintenance bypass switch operation



O**T****E**

The internal MBS consists of two switches and failure to understand the correct sequence may drop the critical load.

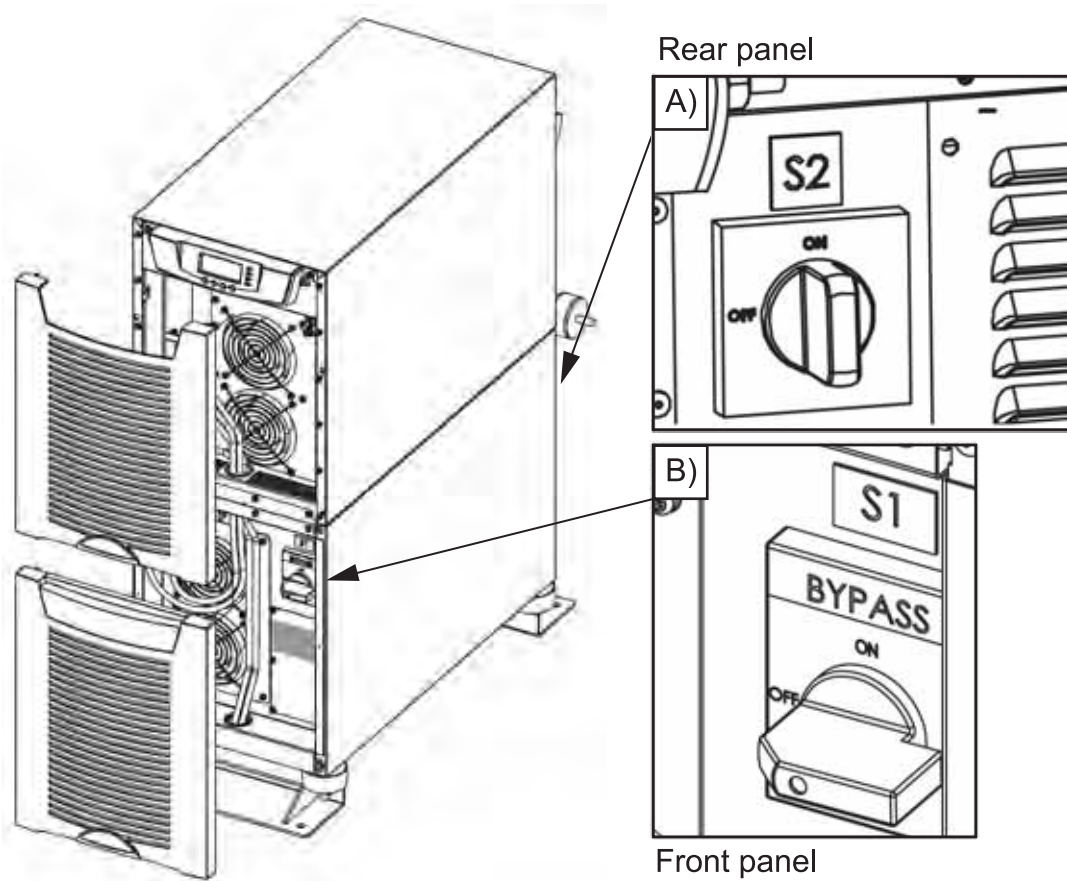

Figure 9-1: The normal (UPS supplying the load) positions of the MBS switches

9.3.1.1 Turn UPS from normal mode to mechanical bypass

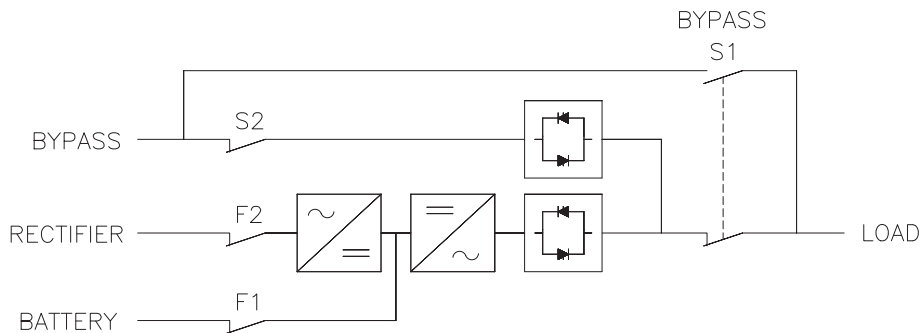

Figure 9-2: The normal positions of the MBS switches

The procedure to turn the UPS to mechanical bypass switch is described below.

1. The normal start position should be as shown below:

S1	S2
OFF	ON

- Use the UPS LCD commands to transfer the UPS to static bypass mode. Remember to verify the transfer before proceeding to the next step.
- Turn the **S1** bypass switch to the ON position to bypass the UPS and to disconnect the UPS output:

S1	S2
ON	ON

- Use the UPS LCD commands to turn the UPS OFF.
- Turn the battery breaker **F1** and the rectifier input breaker **F2** to the OFF position.
- Turn the **S2** switch to the OFF position to disconnect the UPS static bypass input:

S1	S2
ON	OFF

- The UPS is now in the mechanical bypass mode, see below:

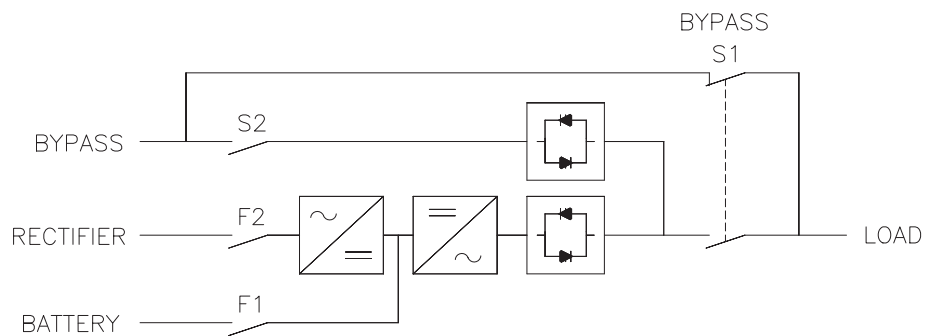

Figure 9-3: The positions of the MBS switches in the mechanical bypass mode

9.3.1.2 Turn UPS from mechanical bypass to normal mode

The procedure to turn the UPS back to normal mode is described below.

- The normal start position should be as shown below:

S1	S2
ON	OFF

- Turn the **S2** switch to the ON position to connect the static bypass input to the UPS:

S1	S2
ON	ON

3. Turn the battery breaker **F1** and the rectifier input breaker **F2** to the ON position.
4. Use the UPS LCD commands to turn the UPS ON and wait until it is fully started. Make sure the UPS is not displaying any alarms. You may verify the output voltage from the meters of the LCD display.
5. Use the UPS LCD commands to transfer the UPS to static bypass mode. Remember to verify the transfer before proceeding to the next step.
6. Turn the **S1** bypass switch to OFF position to connect the UPS output to the load and to disconnect the mechanical bypass output:

S1	S2
OFF	ON

7. Use the UPS LCD commands to transfer the UPS to Normal mode.
8. The UPS is now in the Normal mode, see below:

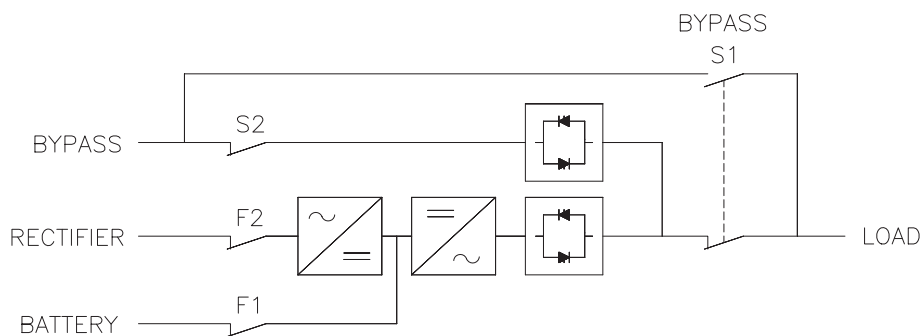

9.3.2 Maintenance bypass switch operation



OTE

The MBS consists of three switches and failure to understand the correct sequence may drop the critical load.

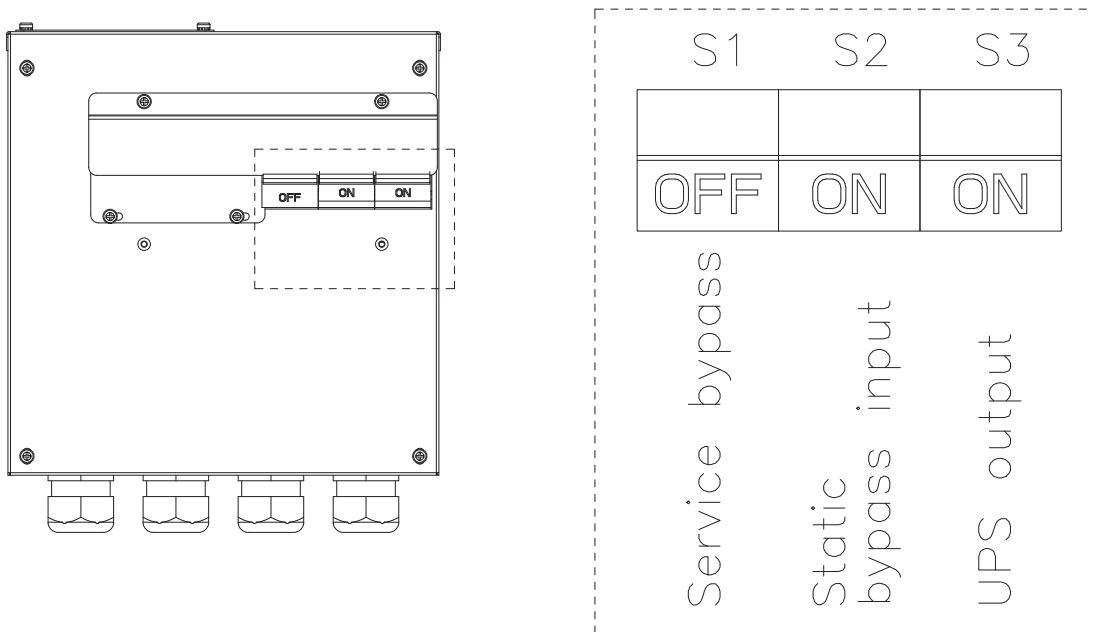

Figure 9-4: The normal (UPS supplying the load) positions of the MBS switches

9.3.2.1 Turn UPS from normal mode to mechanical bypass

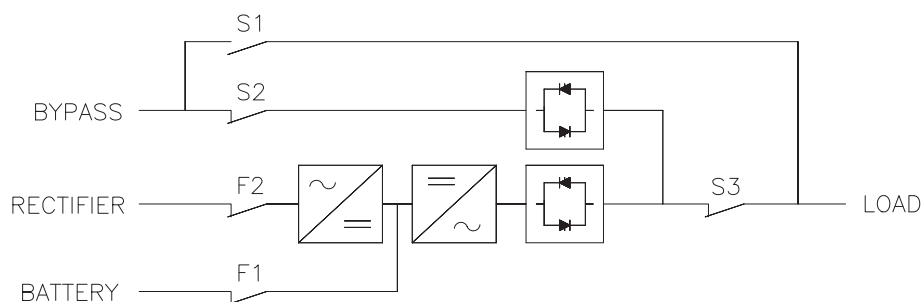

Figure 9-5: The normal positions of the three MBS switches

The procedure to turn the UPS to mechanical bypass switch is described below.

1. The normal start position should be as shown below:

S1	S2	S3
OFF	ON	ON

2. Use the UPS LCD commands to transfer the UPS to static bypass mode. Remember to verify the transfer before proceeding to the next step.
3. Remove the locking plate of the S1-3 switches.
4. Turn the **S1** switch to the ON position to bypass the UPS:

S1	S2	S3
ON	ON	ON

- Turn the **S3** switch to the OFF position to disconnect the UPS output:

S1	S2	S3
ON	ON	OFF

- Use the UPS LCD commands to turn the UPS OFF.
- Turn the battery breaker **F1** and the rectifier input breaker **F2** to the OFF position.
- Turn the **S2** switch to the OFF position to disconnect the UPS static bypass input:

S1	S2	S3
ON	OFF	OFF

- Remount the locking plate of the S1-3 switches to prevent the use of them.
- The UPS is now in the mechanical bypass mode, see below:

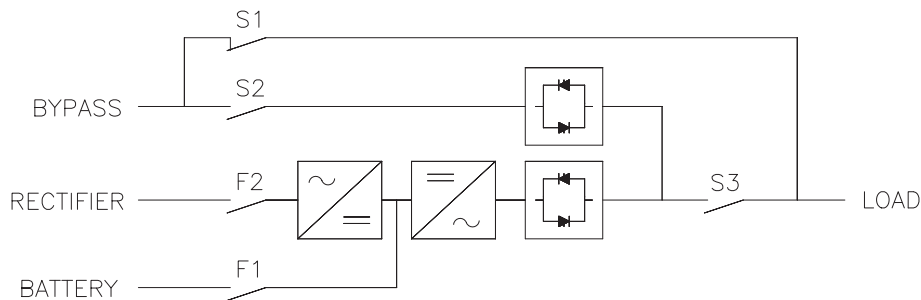

Figure 9-6: The positions of the three MBS switches in the mechanical bypass mode

9.3.2.2 Turn UPS from mechanical bypass to normal mode

The procedure to turn the UPS back to normal mode is described below.

- The normal start position should be as shown below:

S1	S2	S3
ON	OFF	OFF

- Remove the locking plate of the S1-3 switches.
- Turn the **S2** switch to the ON position to connect the static bypass input to the UPS:

4. Turn the battery breaker **F1** and the rectifier input breaker **F2** to the ON position.
5. Use the UPS LCD commands to turn the UPS ON and wait until it is fully started. Make sure the UPS is not displaying any alarms. You may verify the output voltage from the meters of the LCD display.
6. Use the UPS LCD commands to transfer the UPS to static bypass mode. Remember to verify the transfer before proceeding to the next step.
7. Turn the **S3** switch to ON position to connect the UPS output to the load:
8. Turn the **S1** switch to OFF position to disconnect the mechanical bypass output

S1	S2	S3
OFF	ON	ON

9. Use the UPS LCD commands to transfer the UPS to Normal mode.
10. Remount the locking plate of the S1-3 switches to prevent the use of them.
11. The UPS is now in the Normal mode, see below:

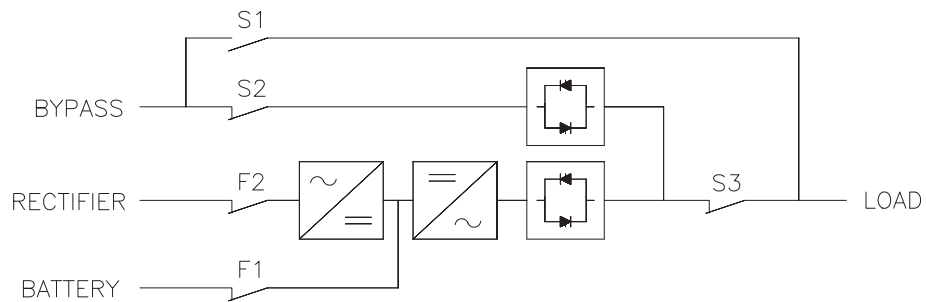

Figure 9-7: The normal positions of the MBS switches in the Normal mode

10 Parallel systems

0.1 Overview

Parallel UPS configurations are recognised as either redundancy or capacity systems. The redundancy system is used to improve the system reliability with N+1 redundant UPS module. The capacity system for its part provides the maximum output power without focusing to the highest system reliability.

A parameter selection is used to switch between the redundancy and capacity modes. It is important to remember that the mode is affecting to the output power rating and overall system reliability.

UPS modules of the parallel system share equally the load with Hot Sync® technology. The parallel outputs can be combined in a System Parallel Module or cabinet. It is the system component containing the obligatory service switches. Customer's low-voltage distribution panel can also be used instead of the System Parallel Module. In the redundancy system, service switches enable the maintenance or service on an UPS module. In the capacity system, one needs to have a common system bypass switch to do the maintenance or service without safety hazards.

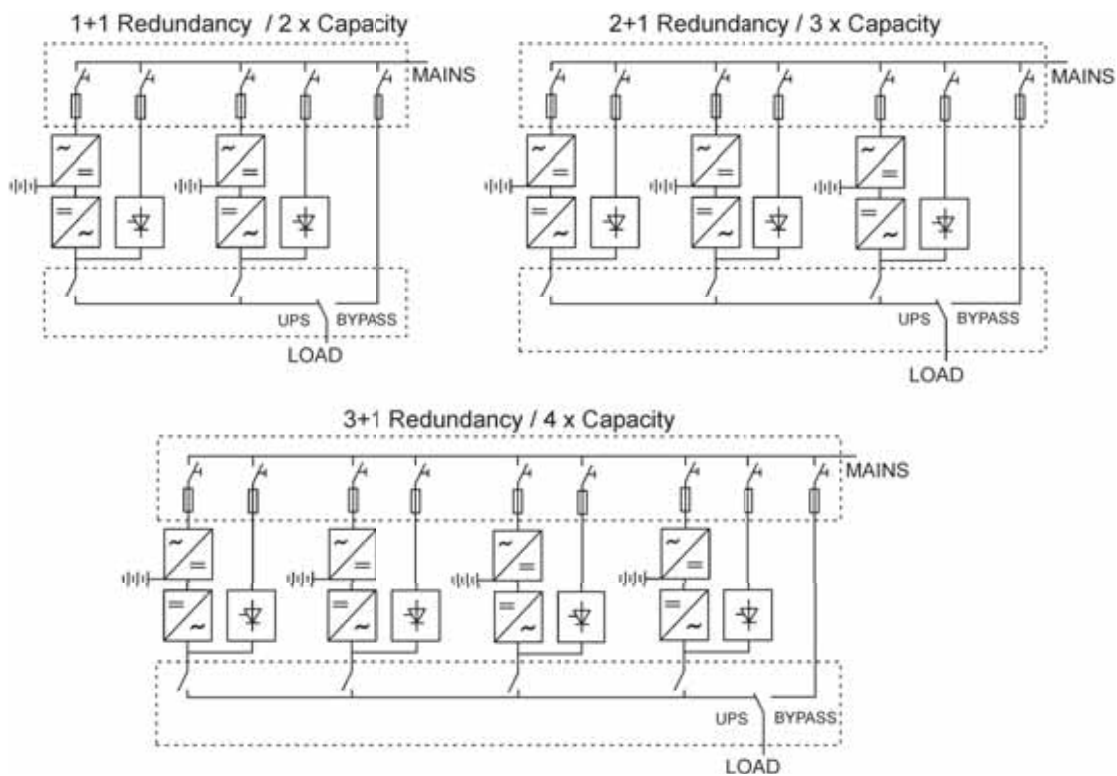

Figure 10-1: Parallel configurations with UPS modules

Field upgrading can be used to extend existing capacity/redundancy systems with UPS modules. The upgrading must be carried out by service personnel from the manufacturer or from an agent authorised by the manufacturer.

10.2 Tie cabinets

The Tie Cabinets (TCs), provided by UPS manufacturer, has input connections up to three parallel UPS modules. It is also possible to use two redundant UPS modules and one bypass connection. This bypass option can be used for service or test purposes.



It is not allowed to feed the load simultaneously from mains (bypass) and inverter(s) of the UPS unit(s). While turning the switch, where the bypass is connected, ON/OFF, UPS should be on static bypass mode or shut down.



The maximum load supported by the system is limited to 15 kVA if there are two UPSs and bypass connected to TC (See wiring diagrams below).

Terminals of the TC have two or four wire connection (L1 and N or L1, L2, L3 and N) and ground terminals. The upper ground terminal is for a load cable and the lower ground terminal is for UPS units. The wiring shall be done according to the wiring diagrams. The cable routing and terminals are shown below.

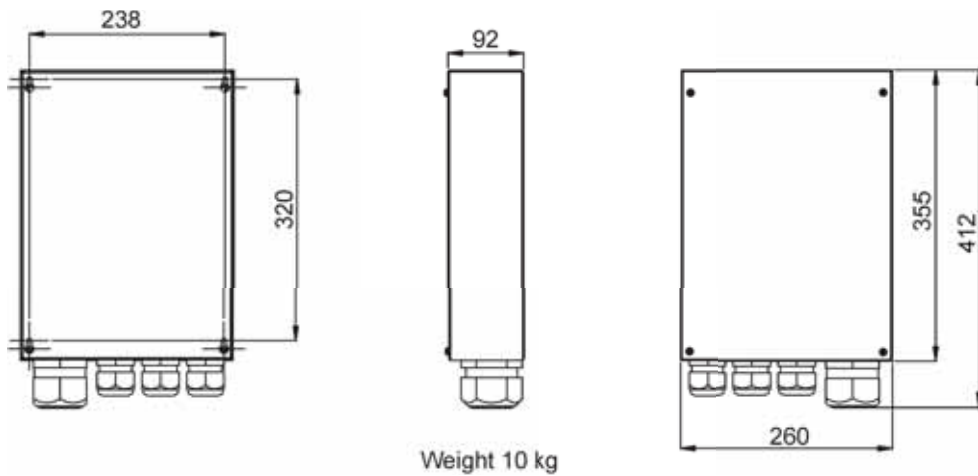

Figure 10-2: Dimensions of the Tie Cabinet

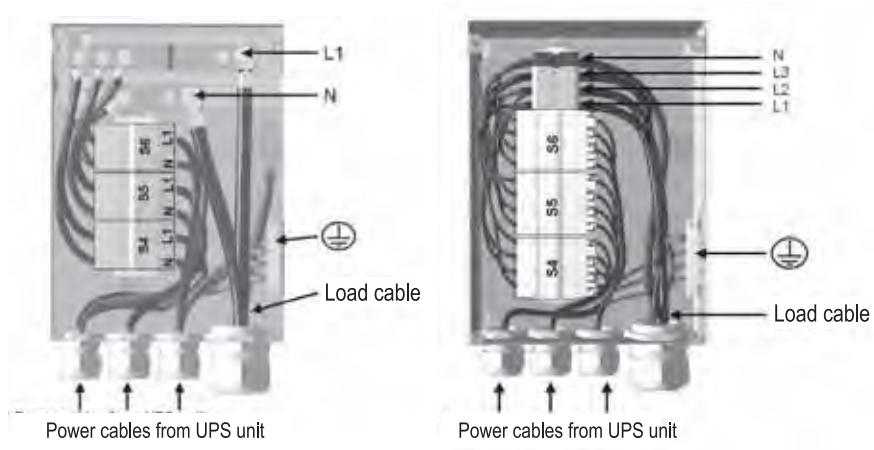

Figure 10-3: Cable routing of the Tie Cabinet: 1-phase model on the left and 3-phase model on the right

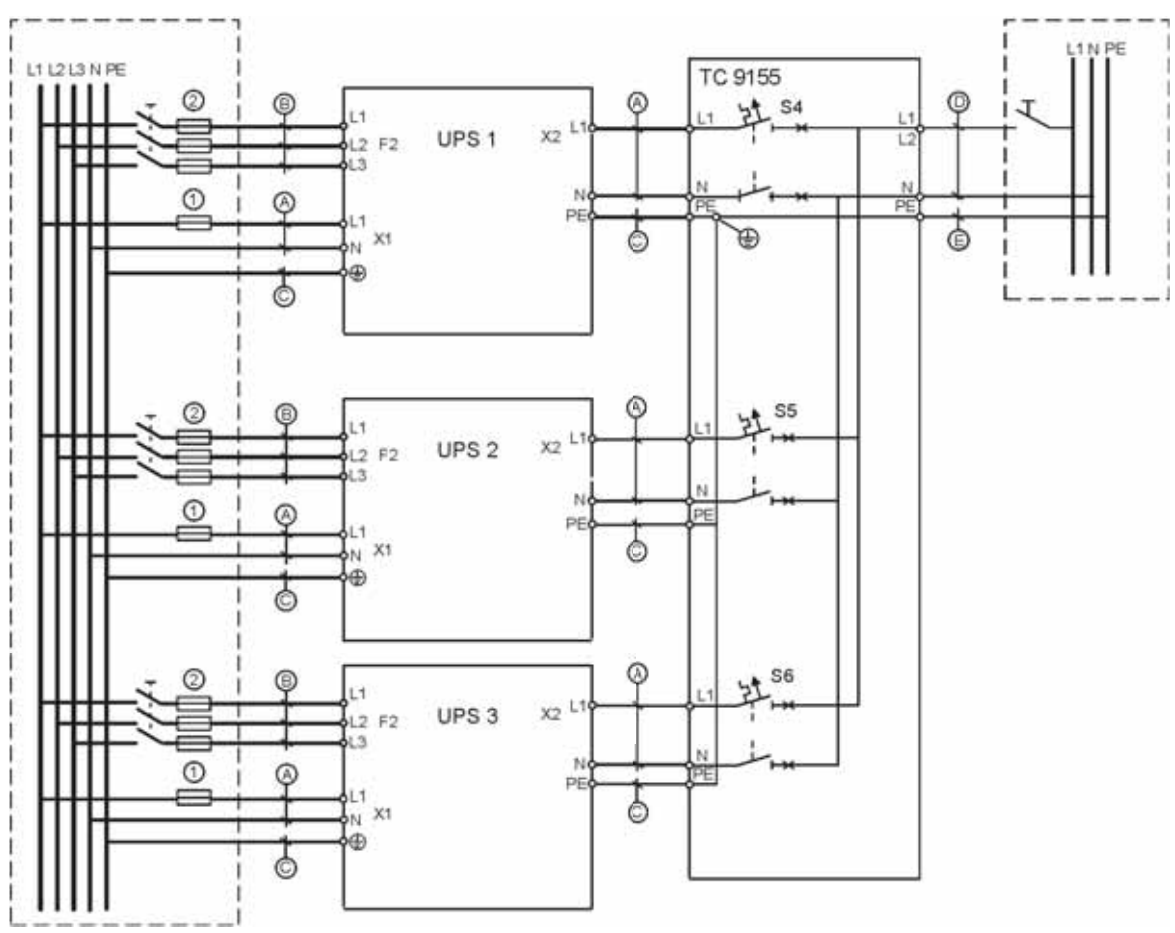

Figure 10-4: 1-phase Tie Cabinet's wiring diagram with three UPS units

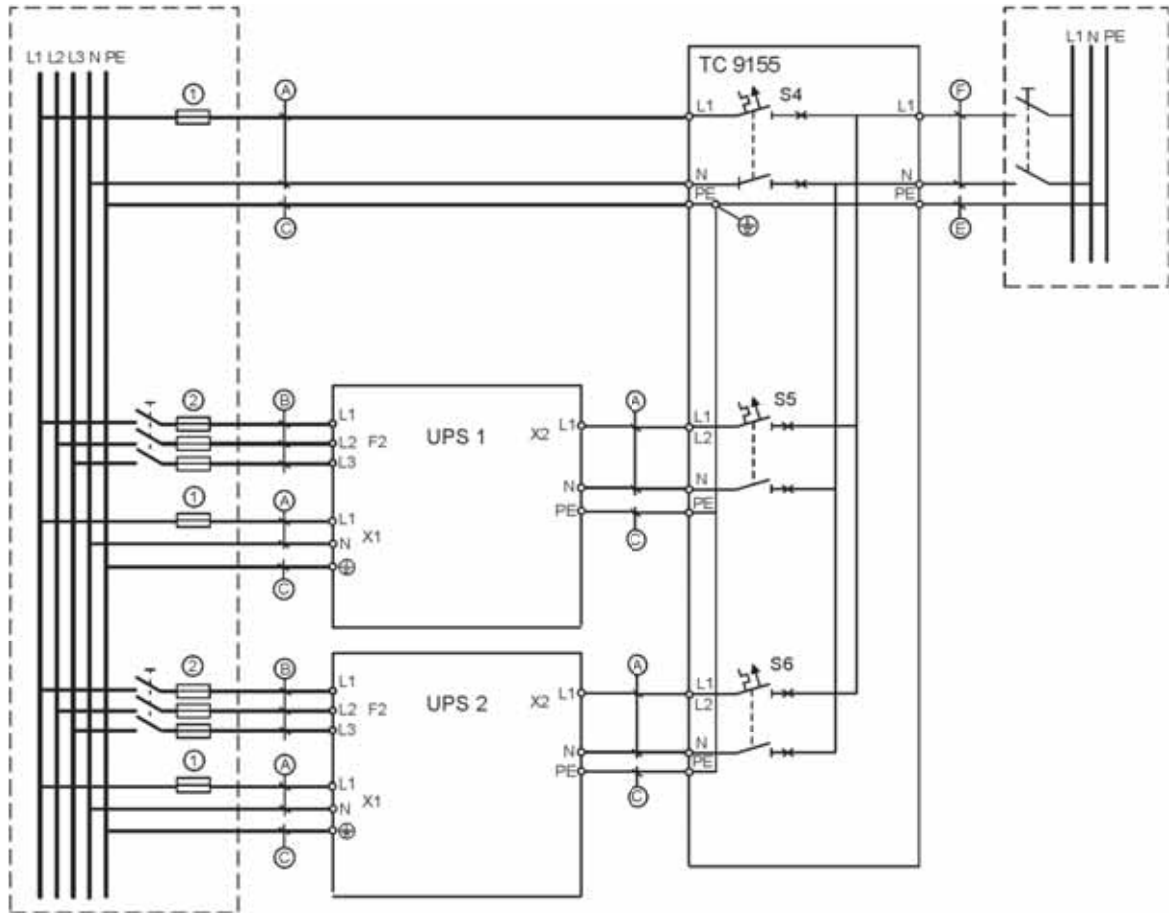

Figure 10-5: 1-phase Tie Cabinet's wiring diagram with two UPS units and bypass connected

UPS Module	Bypass input X1			Rectifier input F2	
	Cable A	Cable C	Fuse 1	Cable B	Fuse 2
8 kVA	10 mm ²	10 mm ²	50 A	2,5 mm ²	16 A
10 kVA	10 mm ²	10 mm ²	50 A	4 mm ²	20 A
12 kVA	16 mm ²	16 mm ²	63 A	6 mm ²	25 A
15 kVA	25 mm ²	16 mm ²	80 A	6 mm ²	32 A

TC Module	Cable D	Cable E	Cable F
8 kVA	10 mm ²	10 mm ²	10 mm ²
10 kVA	10 mm ²	10 mm ²	10 mm ²
12 kVA	16 mm ²	16 mm ²	16 mm ²
15 kVA	25 mm ²	16 mm ²	25 mm ²
16 kVA	35 mm ²	16 mm ²	(35 mm ²)*

TC Module	Cable D	Cable E	Cable F
20 kVA	35 mm ²	16 mm ²	(35 mm ²)*
24 kVA	70 mm ²	35 mm ²	(70 mm ²)*
30 kVA	70 mm ²	35 mm ²	(70 mm ²)*
36 kVA	95 mm ²	50 mm ²	-
45 kVA	120 mm ²	70 mm ²	-

Table 10-1: Minimum cable and fuse rating for the different parallel system with installation procedure C * (system bypass not allowed)

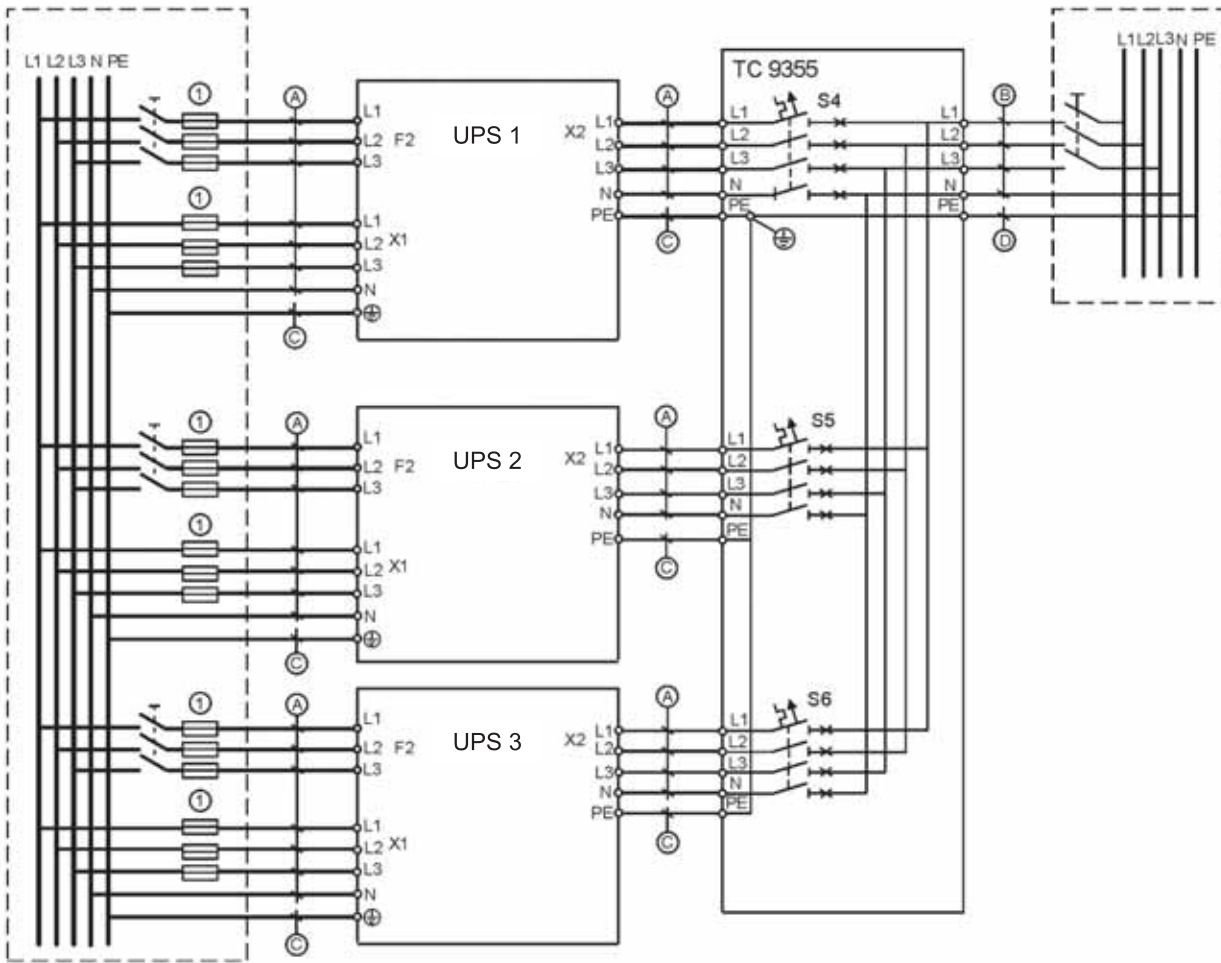

Figure 10-6: 3-phase Tie Cabinet's wiring diagram with three UPS units

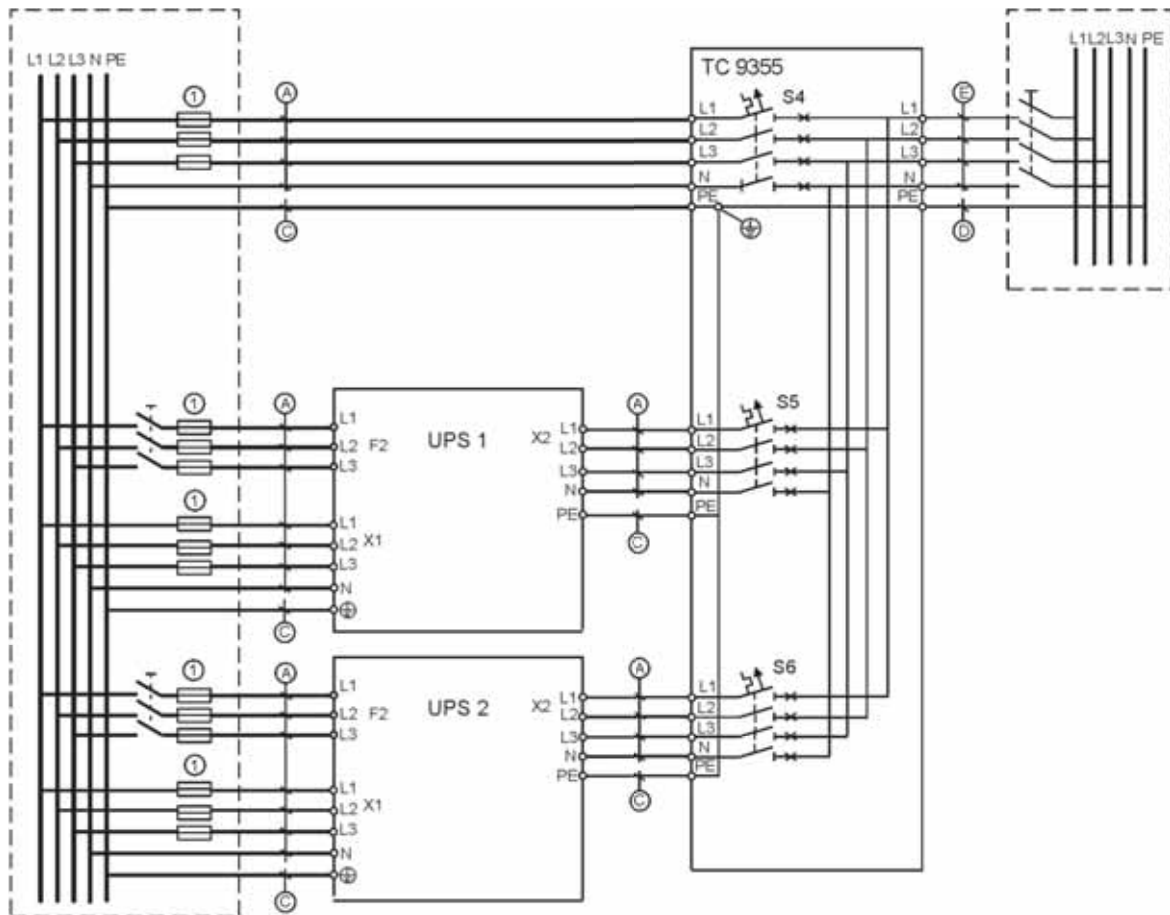

Figure 10-7: 3-phase Tie Cabinet's wiring diagram with two UPS units and bypass connected

UPS Module	Cable A	Cable C	Fuse 1
8 kVA	2,5 mm ²	4 mm ²	16 A
10 kVA	4 mm ²	4 mm ²	20 A
12 kVA	6 mm ²	6 mm ²	25 A
15 kVA	6 mm ²	6 mm ²	32 A
TC Module	Cable B	Cable D	Cable E
8 kVA	2,5 mm ²	4 mm ²	2,5 mm ²
10 kVA	4 mm ²	4 mm ²	4 mm ²
12 kVA	6 mm ²	6 mm ²	6 mm ²
15 kVA	6 mm ²	6 mm ²	6 mm ²
16 kVA	6 mm ²	6 mm ²	(6 mm ²)*
20 kVA	10 mm ²	16 mm ²	(10 mm ²)*

TC Module	Cable B	Cable D	Cable E
24 kVA	10 mm ²	16 mm ²	(10 mm ²)*
30 kVA	16 mm ²	16 mm ²	(16 mm ²)*
36 kVA	16 mm ²	16 mm ²	-
45 kVA	35 mm ²	16 mm ²	-

Table 10-2: Minimum cable and fuse rating for the different parallel system with installation procedure C * (system bypass not allowed)



O TE

Protection fuses need to be used for load cabling if manufacturers Tie Cabinet (or similar) not used.

Required parallel system wiring length should be in accordance with the following rule, as referenced to the diagram below to ensure approximately equal current sharing when in static bypass mode (see Figure below):

Total length of 1A + 1B

= Total length of 2A + 2B

= Total length of 3A + 3B

= Total length of 4A + 4B

This rule has a tolerance of approximately $\pm 10\%$ for the combined input and output wire lengths. If installing only two UPS modules, this requirement is no longer required as each UPS is capable of supporting the full bypass requirement. However, this would preclude future expansion.

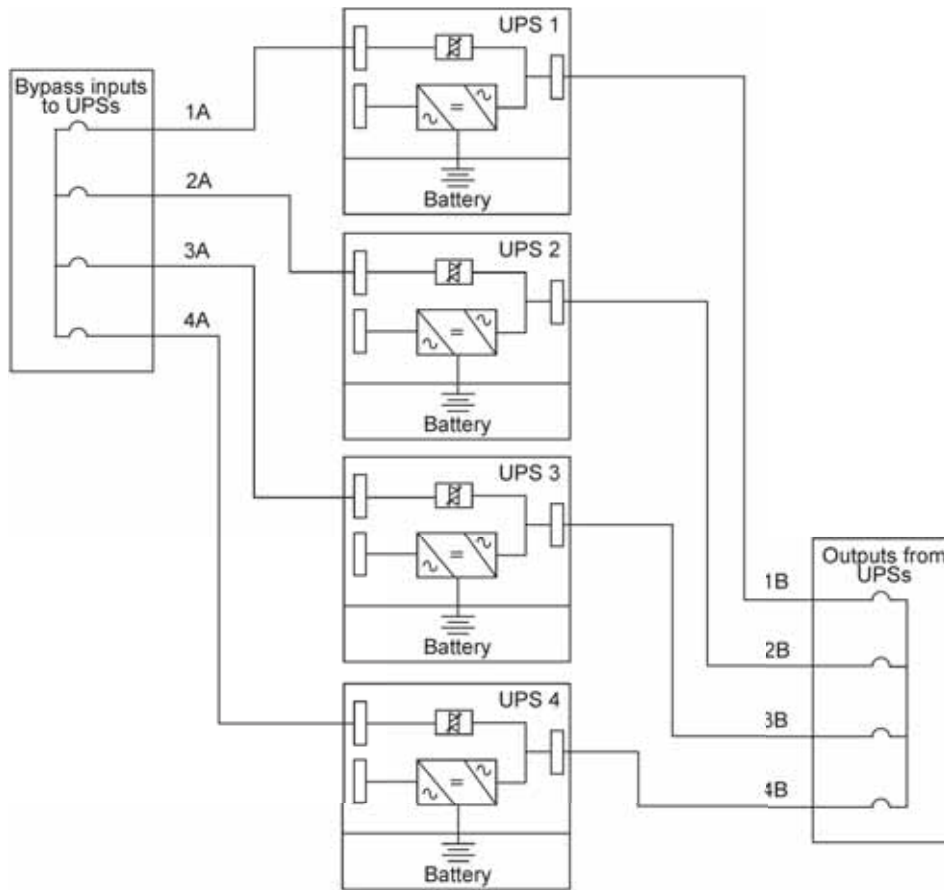

Figure 10-8: Bypass wiring diagram and cable length notes



OPE

Signal input cables need to be connected to all UPS when used.

0.3 XSlot Hot Sync card: installing and wiring

To enable parallel operation, all the UPSs in the system need the XSlot Hot Sync card (see the Figure and Table below) installed into an open XSlot on the front of the UPS, see *Chapter 7.4 XSlot communication (option)* on page 45.

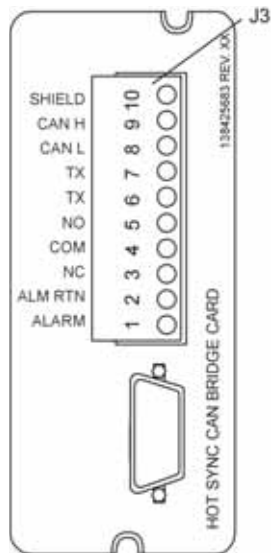

Figure 10-9: XSlot Hot Sync card and terminal interface

Terminal J3	ame	Description
1	Alarm	Programmable UPS alarm. Activated by a remote dry contact closure.
2	Alarm Rtn	
3	Alarm Relay NC	Normally-closed contact opens when UPS is on bypass.
4	Alarm Relay Com	Bypass contact return.
5	Alarm Relay NO	Normally-closed contact closes when UPS is on bypass.
6	TX	Remote Monitor Panel (RMP). Relay Interface Module (RIM), or Supervisory Contact Module (SCM) Connections.
7	TX	
8	CAN L	Controller Area Network (CAN) Input for parallel operation.
9	CAN H	
10	Shield	

Table 10-3: Description for figure XSlot Hot Sync card and terminal interface

The Hot Sync communication wiring procedure should be done with shielded twisted pair (STP) as presented in the figure below. The maximum length of the cable is 40 m with shield connected to the terminal pin 10 from end of the both cables. Pay attention that you don't mix the polarity among the UPS modules.

Communication Wiring Termination			
From UPS 1 CAN card	To UPS 2 CAN card	To UPS 3 CAN card (if installed)	To UPS 4 CAN card (if installed)
J3-8 (L)	J3-8 (L)	J3-8 (L)	J3-8 (L)
J3-9 (H)	J3-9 (H)	J3-9 (H)	J3-9 (H)

Table 10-4: Communication Wiring Termination

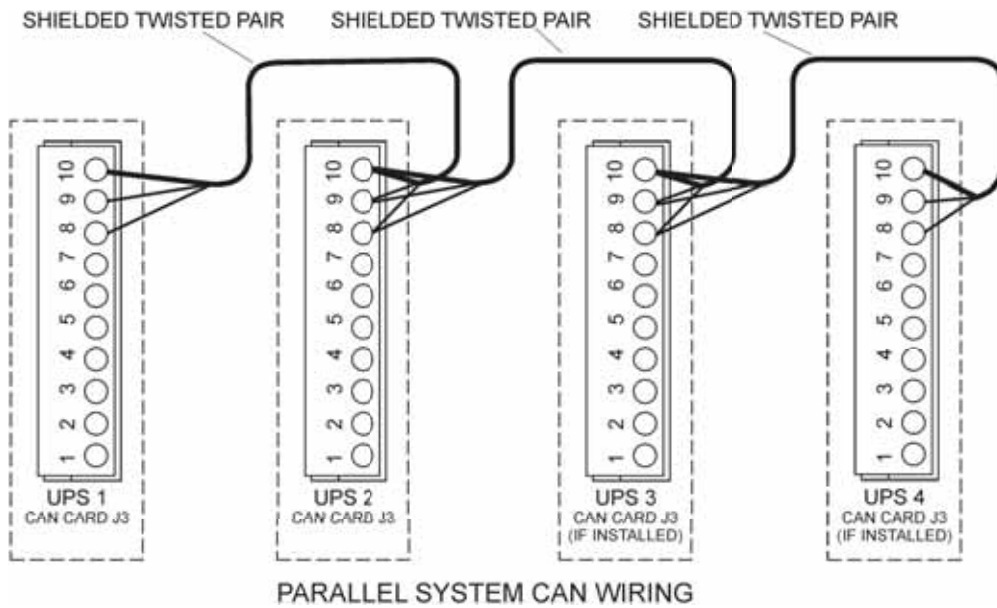
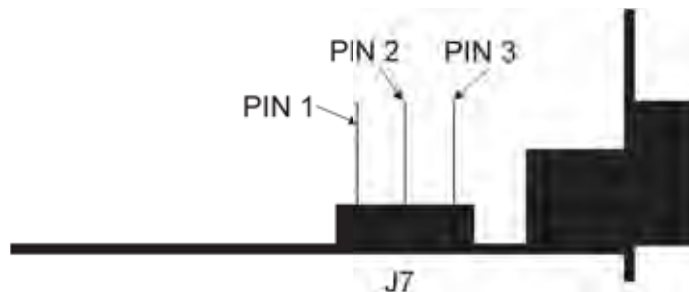

Figure 10-10: Communication cabling wiring



OTE

XSlot Hot Sync card has built-in termination resistor enabled by a jumper J7. The default jumper setting without termination resistor is J7: Pin 2-3. The first and the last UPS modules should have the termination resistor enabled by connecting Pins 1 and 2 with the jumper J7.



Default setting: Resistor ON: PIN 1 and PIN 2 connected, No resistor: PIN 2 and PIN 3 connected

Figure 10-11: XSlot HotSync card and jumper settings

10.4 Parallel operations

Start-up:



O TE

Before start-up make sure that UPS installations have been carried out correctly and ground connections of both UPS units and parallel module have been connected. Check also that the XSlot Hot Sync cards are installed correctly and the communication line between UPSs is connected according to figure Communication cabling wiring.

When installation is completed correctly the start procedure can be started.



O TE

If some settings are changed from User settings the same changes need to be done separately to all of the UPSs in the system.

Carry out the following procedure to each UPS you want to have in system:

1. Turn the battery and input circuit breakers to ON position.
2. UPS will enter a stand-by mode and starts to charge batteries with a cooling fan operational. Output is without the voltage in the stand-by mode.
3. Push any key of the control panel to enable the functions of the LCD screen.
4. Select unit number in parallel system: Unit #1, Unit #2, Unit #3 or Unit #4. Select: SETTINGS -> USER SETTINGS -> PARALLEL OPERATION SETTINGS -> PARALLEL UNIT NUMBER.
5. Select minimum units to support load: 0-4. Select: SETTINGS -> USER SETTINGS -> PARALLEL OPERATION SETTINGS -> MINIMUM UNITS TO SUPPORT LOAD Do the following item (item 6) only for one UPS, which belongs to the system.

Do the following item (item 6) only for one UPS, which belongs to the system.

6. Return to main menu and select TURN SYSTEM ON.

All the UPSs shall check their internal functions, synchronize to bypass and start to supply the load.



O TE

After the first start the load sharing of the system needs to be calibrated. Before starting the calibration the system needs to support some load.

7. Select: SETTINGS -> USER SETTINGS -> PARALLEL OPERATION SETTINGS -> START AUTO CALIBRATION.

Shutdown:

While system is running and UPSs are supporting load, there are two different ways to perform a shutdown. The user can select either to shutdown the whole system or only one UPS.

1. Select TURN SYSTEM OFF from the main menu => All the UPSs in the system will go to stand-by mode.
2. Select TURN UPS OFF => Only the selected UPS will go to stand-by mode.

When UPS is in stand-by mode it still charges its batteries and uses cooling fans. Stand-by mode enables a fast restart. If some UPS or all the UPSs in the system need to be shutdown completely, proceed to item 3.

3. Select TURN UPS OFF and press and hold the return  button for 5 seconds. There shall be an indication sound during the hold.
4. UPS shall do a shutdown routine.
5. Turn the battery and input circuit breakers to off position to finalise the shutdown procedure.

1 Recycling the used UPS or batteries

Before scrapping UPS or its battery cabinet, the battery bank must be removed. Local requirements must be followed in battery recycling or discard. The removal of batteries is allowed only by authorized service personnel due to high energy and voltage.

Do not discard waste electrical or electronic equipment in the trash. For proper disposal, contact your local collecting/recycling/reuse or hazardous waste center and follow the local legislation.

These symbols indicate on a product:



Figure 11-1: WEEE symbol

Use proper local collecting centers meeting local legislation when handling waste of electrical and electronic equipment.



WARNING

HAZARDOUS MATERIALS. Batteries may contain **HIGH VOLTAGES**, and **CAUSTIC, TOXIC** and **FLAMMABLE** substances. Batteries can injure or kill people and damage equipment if used improperly. **DO NOT DISCARD** unwanted batteries or battery material in the public waste disposal system. Follow **ALL** applicable, local regulations for storage, handling and disposal of batteries and battery materials.



Figure 11-2: Recycling batteries symbol

12 Dimensional drawings

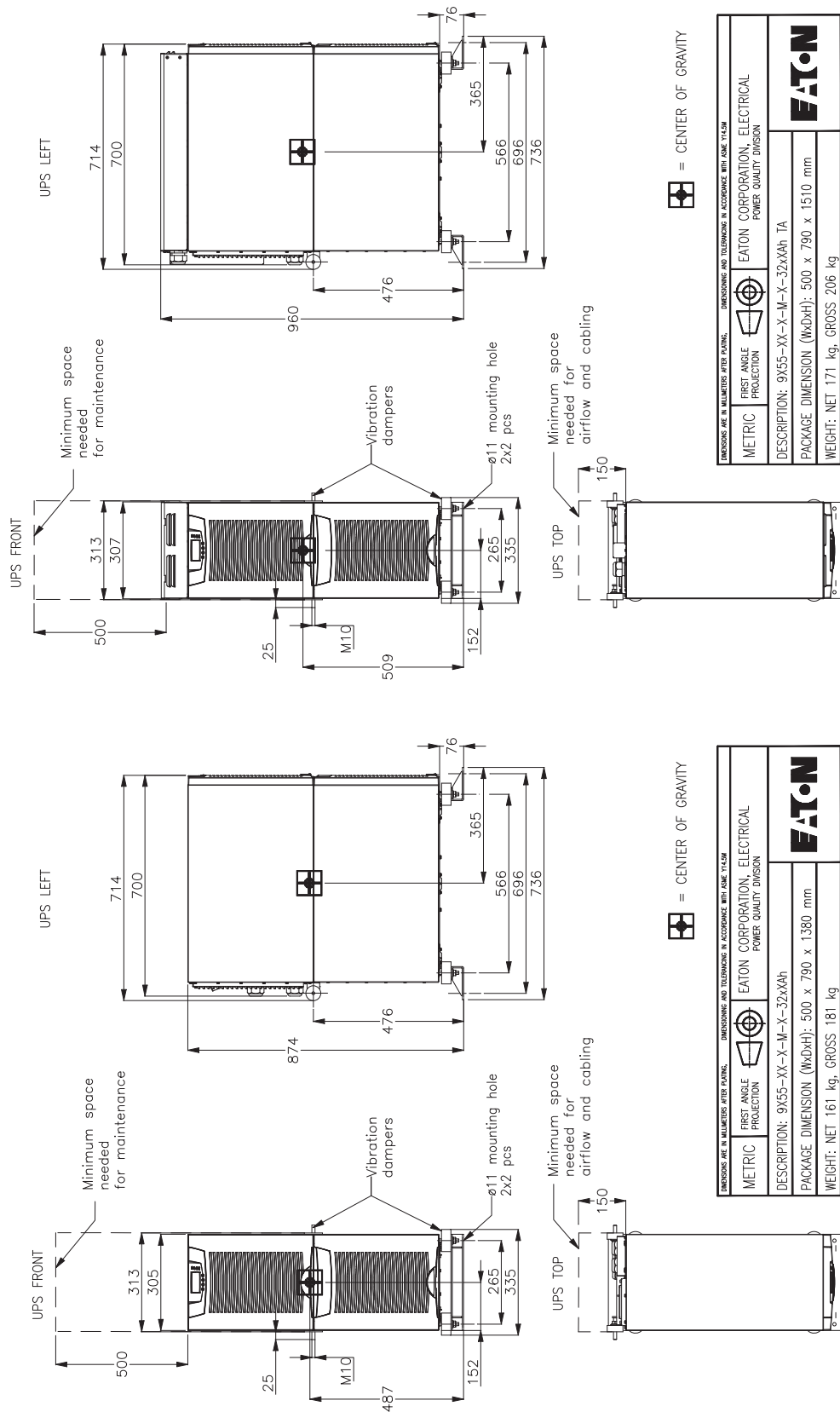

Figure 12-1: Standard and type approved marine UPS models with one bottom battery module

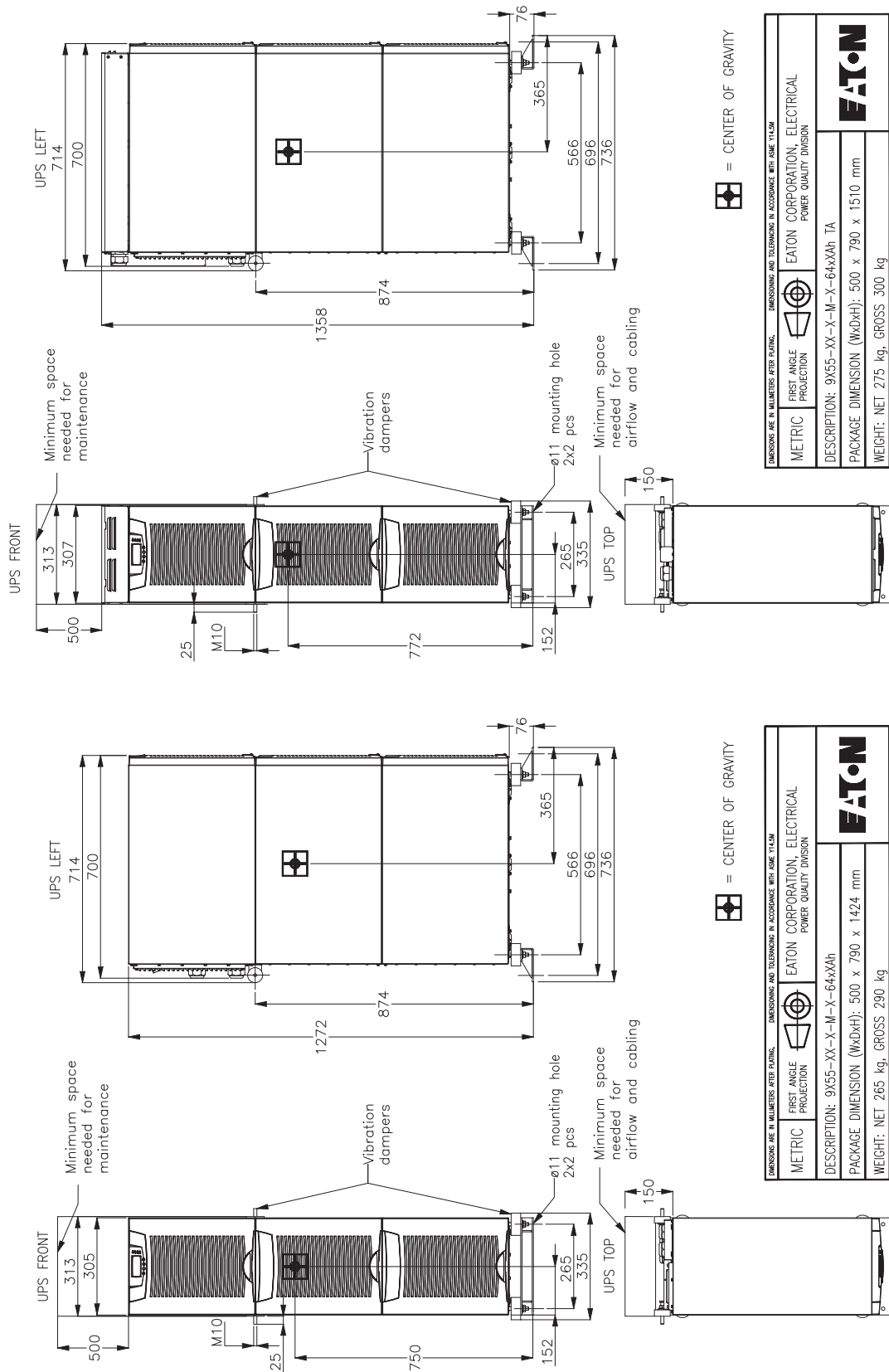

Figure 12-2: Standard and type approved marine UPS models with two bottom battery modules

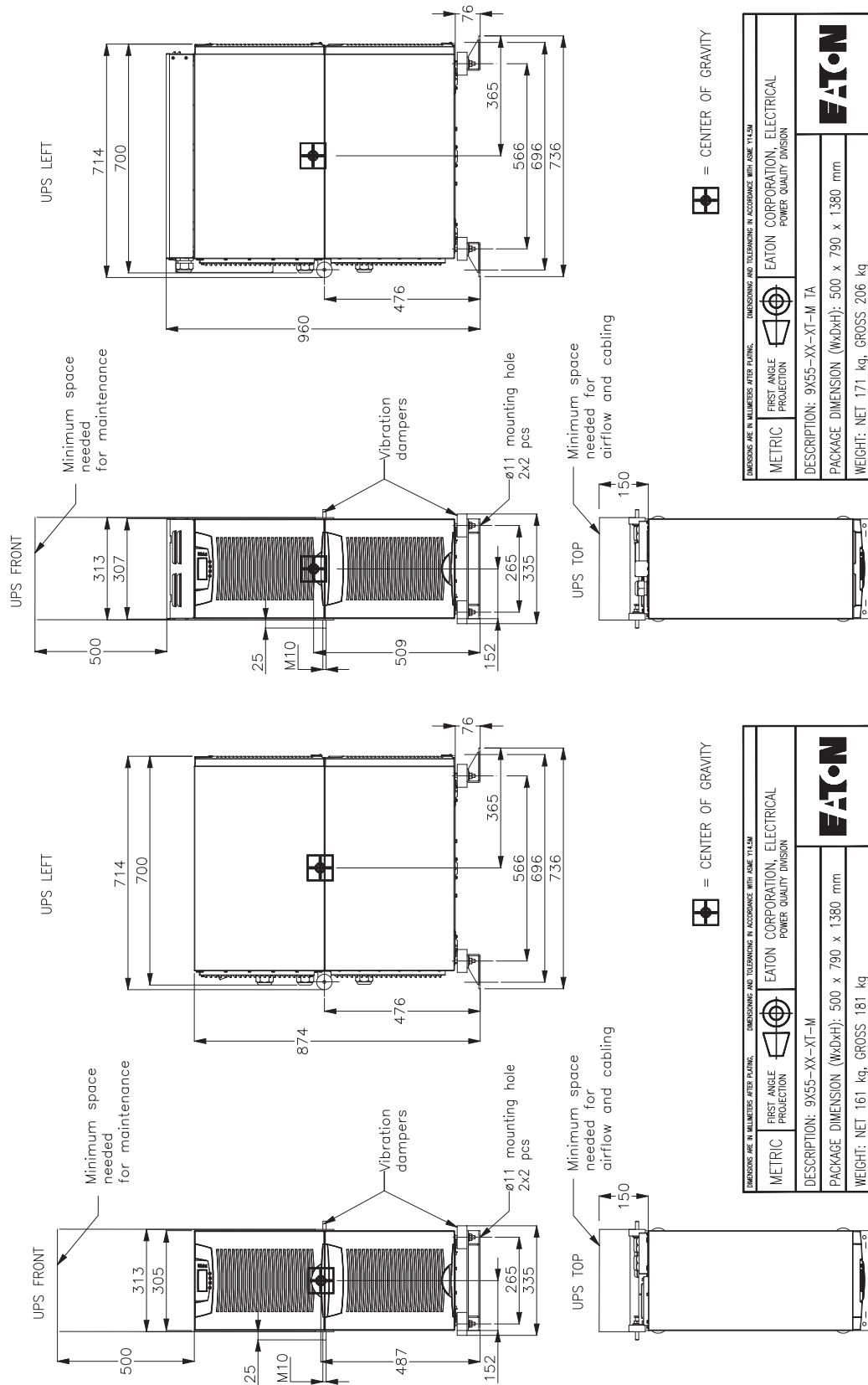

Figure 12-3: Standard and type approved marine UPS models with one bottom transformer module

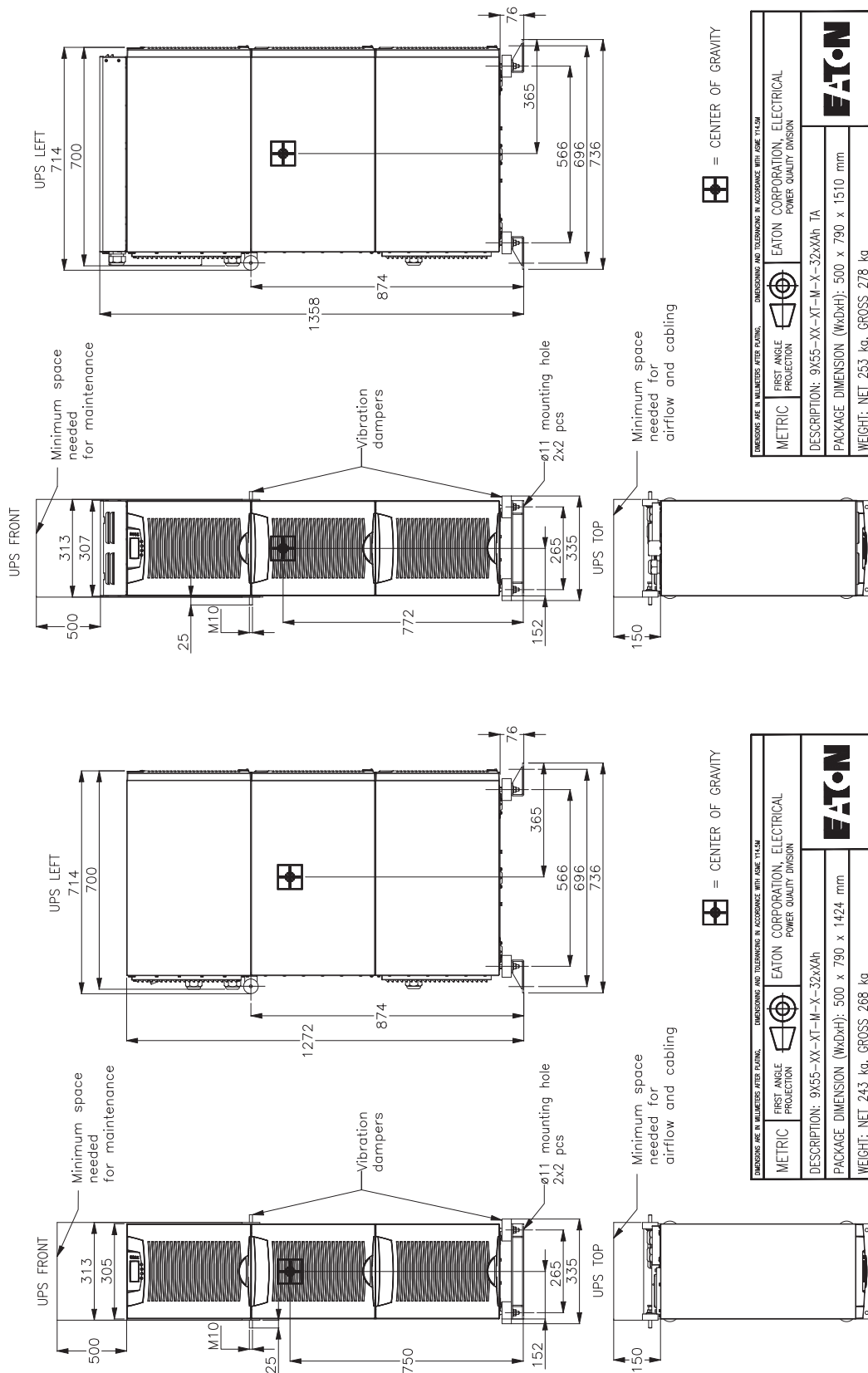

Figure 12-4: Standard and type approved marine UPS models with middle battery and bottom transformer module

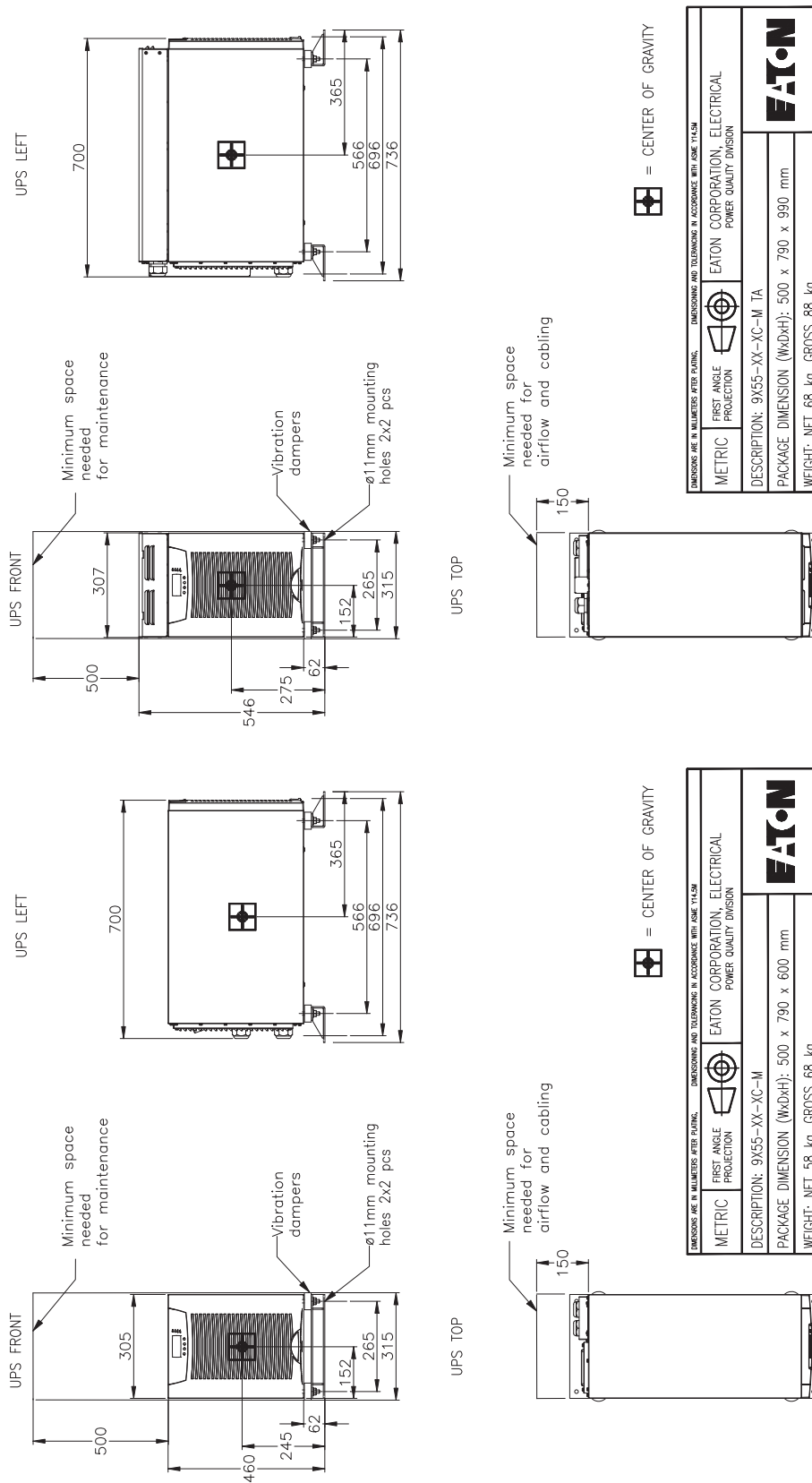

Figure 12-5: Standard and type approved marine UPS models with no battery or transformer modules

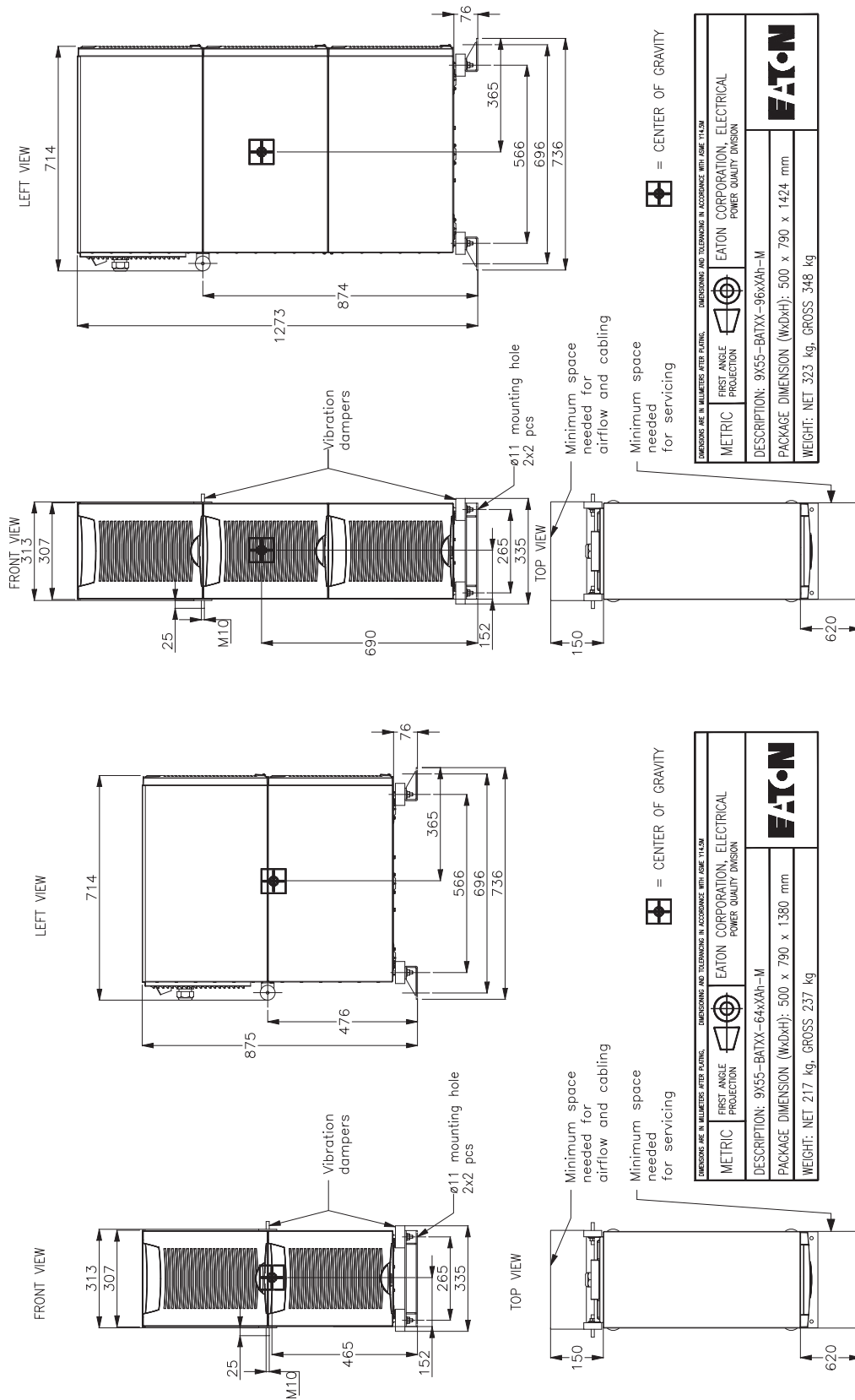

Figure 12-6: External battery cabinet models with two and three modules

13 Wiring diagrams for internal transformer

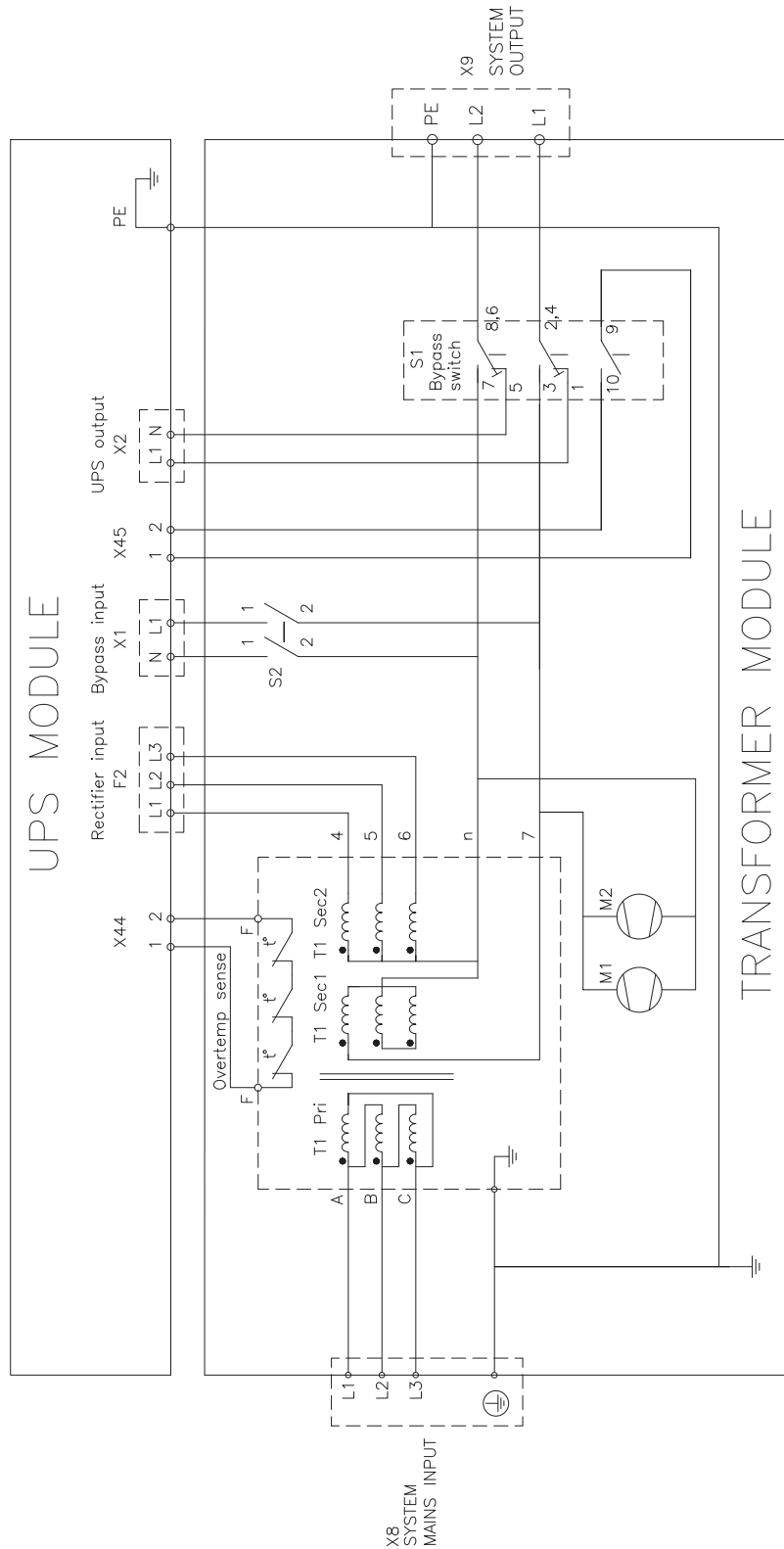

Figure 13-1: Internal transformer wirings for 9155 NT model

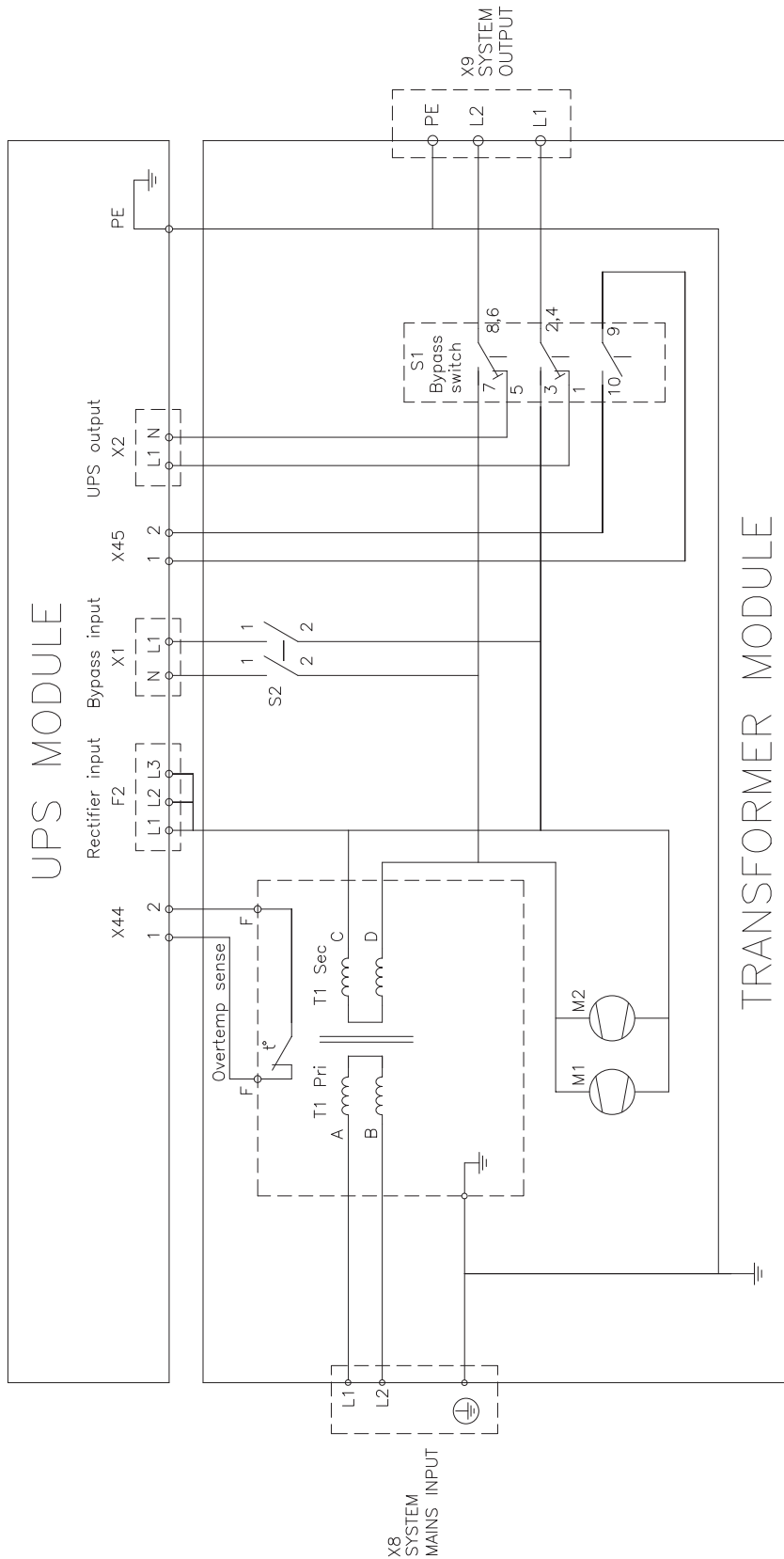

Figure 13-2: Internal transformer wirings for 9155 ST model

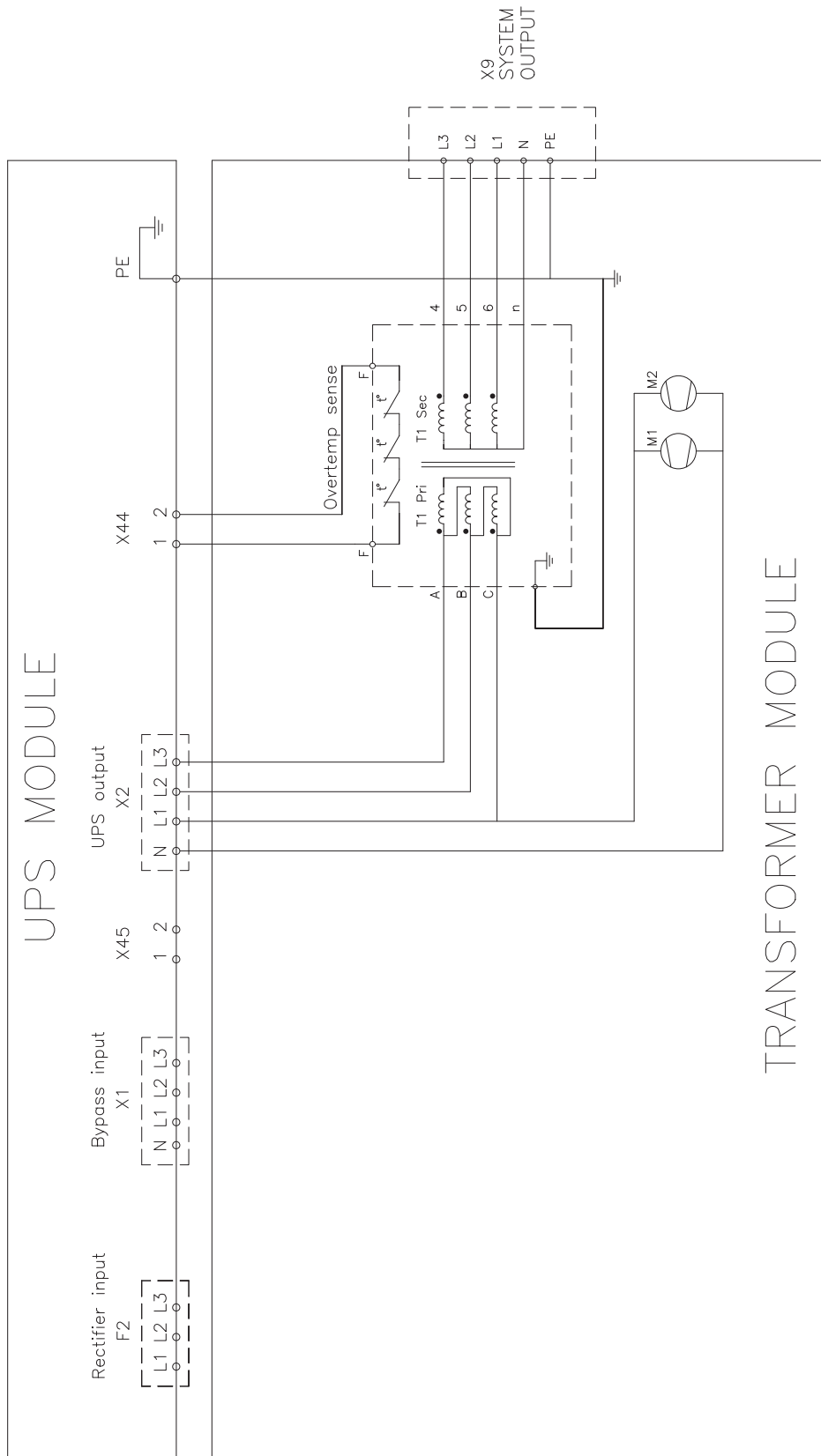

Figure 13-3: Internal transformer wirings for 9355 NT model

14 Technical data

Standards

UPS	8 kVA	10 kVA	12 kVA	15 kVA
Safety	IEC 62040-1-1, EN 62040-1-1 and EN 60950			
EMC	IEC 62040-2, IEC 60945			
Product	IEC 62040-3 and EN 62040-3			
Approvals	CE, DNV Type Approval, ABS Product Design Assessment (Other classification survey reports on request)			

Table 14-1: Standards

Environment

UPS	8 kVA	10 kVA	12 kVA	15 kVA
Ambient temperature	0 to +40°C (electronics), max. +45°C with 7.5% derating 15 to +25°C (batteries)			
Relative humidity	0 to 95%, no condensation allowed			
Altitude	< 1000m above sea level at +40°C, max. 2000m with 1% derating per +100m			
Vibration	IEC 60068-2-64 / DNV Class A; Endurance: Total RMS 1G (3-100 Hz)			

Table 14-2: Environment

Mechanical configuration

UPS	8 kVA	10 kVA	12 kVA	15 kVA
Dimensions	Width 335 mm			
	Depth 736 mm (Rear-mounted MBS: +108 mm)			
	Height 874 mm (2 modules) / 1272 mm (3 modules) (TA models: +86 mm)			
Weight	No battery: 81 kg		No battery: 105 kg	
	32 battery: 161 kg		32 battery: 161 kg	
	64 battery: 265 kg		64 battery: 265 kg	
	Transformer: 161 kg		Transformer: 161 kg	

UPS	8 kVA	10 kVA	12 kVA	15 kVA
	32 battery and transformer: 243 kg		32 battery and transformer: 243 kg	
	TA models: +20kg		TA models: +20kg	
MBS	Rear mounted MBS: +15 kg			
Colour	RAL 7035			

Table 14-3: Mechanical configuration

Characteristics

UPS	8 kVA	10 kVA	12 kVA	15 kVA
Efficiency (Nominal load)	Up to 92%	Up to 93%	Up to 92%	Up to 93%
Heat losses	<580 W	<720 W	<870 W	<1050 W
Backup time with internal batteries	10 min (32 bat 7 Ah)	6 min (32 bat 7 Ah)	8 min (32 bat 9 Ah)	5 min (32 bat 9 Ah)
(Load pf 0.7 (+25°C amb.)	15 min (32 bat 9 Ah)	10 min (32 bat 9 Ah)	15 min (64 bat 7 Ah)	10 min (64 bat 7 Ah)
<i>Backup time can be extended with external battery cabinets.</i>	28 min (64 bat 7 Ah)	20 min (64 bat 7 Ah)	20 min (64 bat 9 Ah)	15 min (64 bat 9 Ah)
	33 min (64 bat 9 Ah)	25 min (64 bat 9 Ah)		
Noise (ISO 7779)	50 - 53 dB(A) depending on the load			

Table 14-4: Characteristics

The represented Efficiency and Heat loss values are for models without transformers.

C input

UPS	8 kVA	10 kVA	12 kVA	15 kVA
Rectifier input	S/ST/SC model: 1-phase (2-phase)		–	–
	/NT/NC model : 3 phases		3 phases	3 phases
Bypass input	(9155): 1-phase (2-phase) (9355): 3-phase			

UPS	8 kVA	10 kVA	12 kVA	15 kVA
Voltage (L-N) without transformer	192 to 253 Volts without using battery			
Voltage (L-N) with input transformer	±5% of system nominal voltage without using battery			
Frequency	45 to 65 Hz			
Power factor	0.99			
Input distortion	< 5% THD(I)			

Rated input current	Input voltage	8 kVA	10 kVA	12 kVA	15 kVA
3-phase	120 V	39 A	49 A	58 A	73 A
	230 V	21 A	26 A	31 A	38 A
	400 V	12 A	15 A	18 A	22 A
	440 V	11 A	14 A	16 A	20 A
	480 V	10 A	13 A	15 A	19 A
	690 V	7 A	9 A	11 A	13 A
1-phase	120 V	67 A	84 A	-	-
	230 V	35 A	44 A	-	-
	400 V	20 A	25 A	-	-
	440 V	19 A	23 A	-	-
	480 V	17 A	21 A	-	-
	690 V	12 A	15 A	-	-

Table 14-5: AC input

DC circuit

UPS	8 kVA	10 kVA	12 kVA	15 kVA
Management	Advanced Battery Management			
Nominal voltage	384 Volts			
Battery qty	32 pcs.			
Float voltage	2.30 VPC			

UPS	8 kVA	10 kVA	12 kVA	15 kVA
Battery type	VRLA 12 Volts			
Cut off voltage	1.75 VPC			
Battery charging	Default: 3 Amps, user selectable Maximum charging current: 25 Amps (Step 0.1 A)			

Table 14-6: DC circuit

C output

UPS	8 kVA	10 kVA	12 kVA	15 kVA
Active power	7,2 kW	9 kW	10,8 kW	13,5 kW
Nro. of phases	1-phase (2-phase) or 3-phase			
Frequency	50 Hz or 60 Hz, user selectable			
Nominal voltage rating	(9155) : 220, 230 or 240 Volts, user selectable			
	(9355) : 380, 400 or 415 Volts, user selectable			
	With internal transformer : 120, 230, 400, 440, 480 or 690 Volts			
	8 kVA	10 kVA	12 kVA	15 kVA
Short circuit capability	(9155) : 100 A, < 300 ms		(9155) : 144 A, < 300 ms	
	(9355) : 55 A, < 300 ms			
Overload capability	min >100-110% load			
	1 min > 110-125% load			
	5 sec >125-150% load			
	300 ms >150% load			

Table 14-7: AC output

The represented short circuit values are for models without tra sformers.

5 Warranty

The product is warranted against defects in design, materials and workmanship for a period of twelve (12) months from its original date of purchase. The local office or distributor may grant a warranty period different to the above and refer to local terms of liability as defined in the supply contract.

The UPS manufacturer is not responsible for:

- Any costs resulting from a failure if the installation, commissioning, repair, alteration, or ambient conditions of the equipment do not fulfil the requirements specified in the documentation delivered with the unit and other relevant documentation.
- Equipment subjected to misuse, negligence or accident.
- Equipment comprised of materials provided or designs stipulated by the purchaser.

Under no circumstances shall the manufacturer, its suppliers or subcontractors be liable for special, indirect, incidental or consequential damages, losses or penalties.

The technical data, information and specifications are valid at the time of printing. The UPS manufacturer reserves the right to modifications without prior notice.