

TOP ENTRY CONDUIT LANDING PLATE
(TOP COVER REMOVED FOR CLARITY)

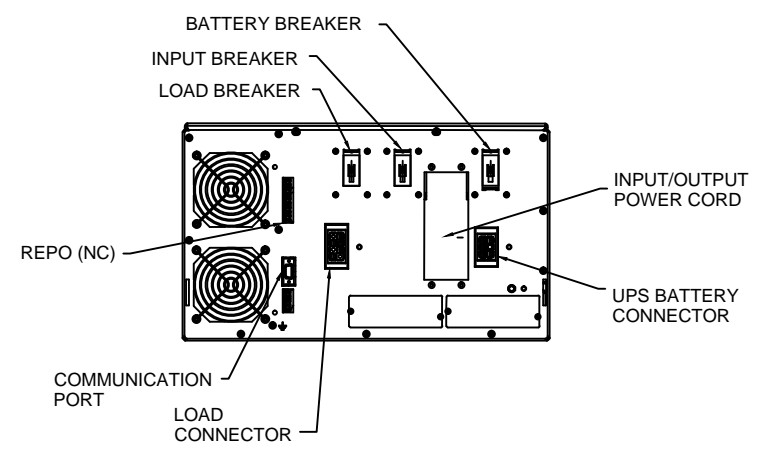

- NOTES
- FOR OPTIONAL MOUNTING BRACKETS USE SHIPPING BRACKETS.
 - CENTER OF GRAVITY AND WEIGHT: SEE TABLE
 - THE SYSTEM MUST BE INSTALLED ON A LEVEL FLOOR SURFACE SUITABLE FOR COMPUTER OR ELECTRONIC EQUIPMENT.
 - THE SYSTEM MUST BE INSTALLED IN A TEMPERATURE AND HUMIDITY CONTROLLED INDOOR AREA FREE OF CONDUCTIVE CONTAMINANTS.
 - AMBIENT TEMPERATURE RANGE 0-40°C [32-104°F]; RECOMMENDED OPERATING RANGE: 20-25°C [68-77°F]; MAXIMUM RELATIVE HUMIDITY: 95% NON-CONDENSING.
 - MINIMUM 900MM [36 IN] FRONT ACCESS AND 900MM [36 IN] REAR ACCESS NEEDED FOR SERVICING.
 - MINIMUM 400 MM [15.7 IN] CLEARANCE IN REAR, NOT INCLUDING CUSTOMER CONNECTION COVER, IS NEEDED FOR VENTILATION EXHAUST.
 - MINIMUM 575MM [22.6 IN] CLEARANCE IN FRONT IS NEEDED FOR COOLING AIR INTAKE AND DOOR SWING.
 - THE UPS CABINET CAN BE INSTALLED IN LINE-UP-AND-MATCH OR STANDALONE CONFIGURATIONS.
 - BOTTOM OR TOP CABLE ENTRY THROUGH REMOVABLE CONDUIT LANDING PLATE. PLATE SHALL BE CUSTOM MODIFIED TO SUIT CONDUIT SIZES.
 - ALL WIRING IS TO BE IN ACCORDANCE WITH NATIONAL AND LOCAL ELECTRIC CODES.
 - AC INPUT TO UPS RECTIFIER (0.98 MIN PF): 3 PHASES, 1 NEUTRAL, 1 GROUND.
AC OUTPUT TO LOAD: 3 PHASES, 1 NEUTRAL, 1 GROUND.
DC INPUT TO UPS (EXTERNAL BATTERY ONLY): 1 POSITIVE, 1 NEGATIVE, 1 GROUND.
 - SPECIFICATIONS ARE SUBJECT TO CHANGE.

FRONT VIEW

RIGHT SIDE VIEW

TOP ENTRY

RIGHT SIDE VIEW (OUTSIDE PANEL REMOVED) BOTTOM ENTRY CONFIGURATION

REAR VIEW (REAR PANELS REMOVED) BOTTOM ENTRY CONFIGURATION

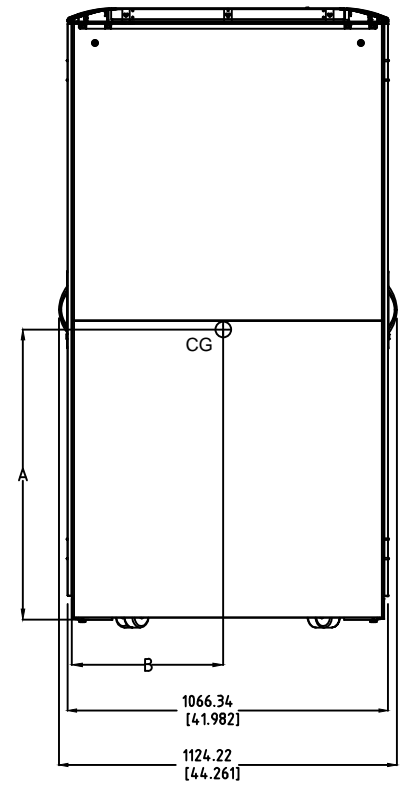
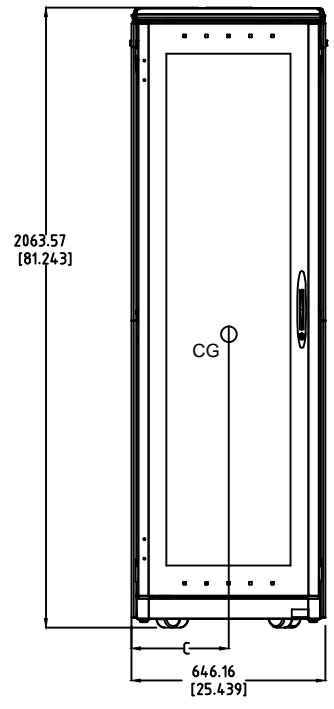

4 HIGH

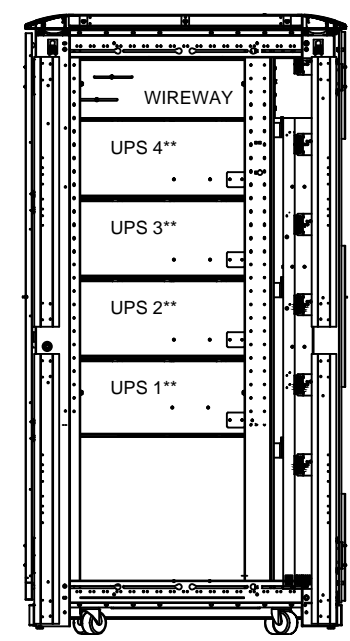

CUSTOMER CONNECTION COVER

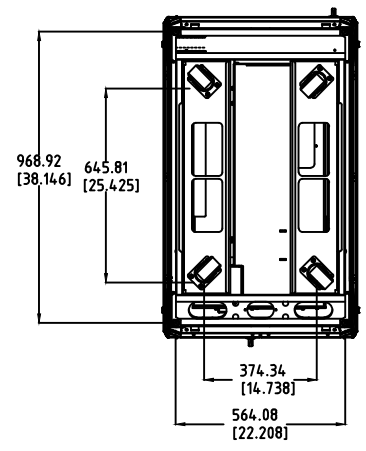
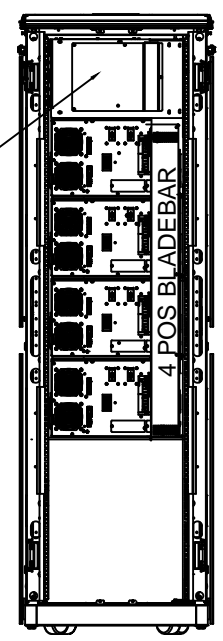

**NOTE: UPS POSITIONS SHOWN ARE REQUIRED FOR ALL CONFIGURATIONS

WEIGHT AND CENTER OF GRAVITY		TOP ENTRY CONFIGURATION		
CONFIGURATION	WEIGHT *	A	B	C
RACK W/ 4 UPS	736.2 kg [1623 lbs]	661 [26.02]	339 [13.35]	226 [8.90]

METRIC	THIRD ANGLE PROJECTION	EATON CORPORATION		EATON	
DIMENSIONS ARE IN MILLIMETERS AFTER PLATING, DIMENSIONS AND TOLERANCES IN ACCORDANCE WITH ASME Y14.5M-1994. SEE NOTES FOR TOLERANCES.					
DESCRIPTION: BLADEUPS SITEPLAN DRW (PRECONFIG-WRIGHTLINE) W/4-POS BLADEBAR (TOP ENTRY)					
ORIGINATED: GOLDEN_D	17-JUL-2012	ECCO:ECO-117817	NAME:	REVISION:04	SIZE: A3
MODIFIED: R. SINGH	23-MAR-2017			STATE:RELEASE	NOT TO SCALE
CHECKED:		DOCUMENT TYPE:	P-110000115-004		SHEET: 1 OF 10
SAFETY:		AUTOCAD DRAWING			
APPROVED:		EATON CORPORATION - CONFIDENTIAL AND PROPRIETARY NOTICE TO PERSONS RECEIVING THIS DOCUMENT AND/OR TECHNICAL INFORMATION			
THIS DOCUMENT, INCLUDING THE DRAWING AND INFORMATION CONTAINED THEREON, IS CONFIDENTIAL AND IS THE EXCLUSIVE PROPERTY OF EATON CORPORATION, AND IS MERELY ON LOAN AND SUBJECT TO RECALL BY EATON AT ANY TIME. BY TAKING POSSESSION OF THIS DOCUMENT, THE RECIPIENT ACKNOWLEDGES AND AGREES THAT THIS DOCUMENT CANNOT BE USED IN ANY MANNER ADVERSE TO THE INTERESTS OF EATON AND THAT NO PORTION OF THIS DOCUMENT MAY BE COPIED OR OTHERWISE REPRODUCED WITHOUT THE PRIOR WRITTEN CONSENT OF EATON. IN THE CASE OF CONFLICTING CONTRACTUAL PROVISIONS, THIS NOTICE SHALL GOVERN THE STATUS OF THIS DOCUMENT. © 2011 Eaton Corporation - All Rights Reserved.					

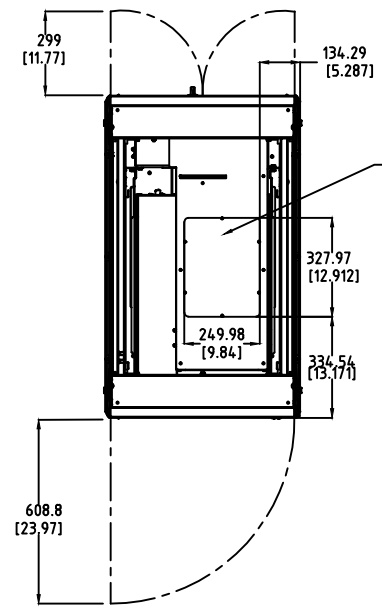

TOP ENTRY CONDUIT LANDING PLATE
(TOP COVER REMOVED FOR CLARITY)

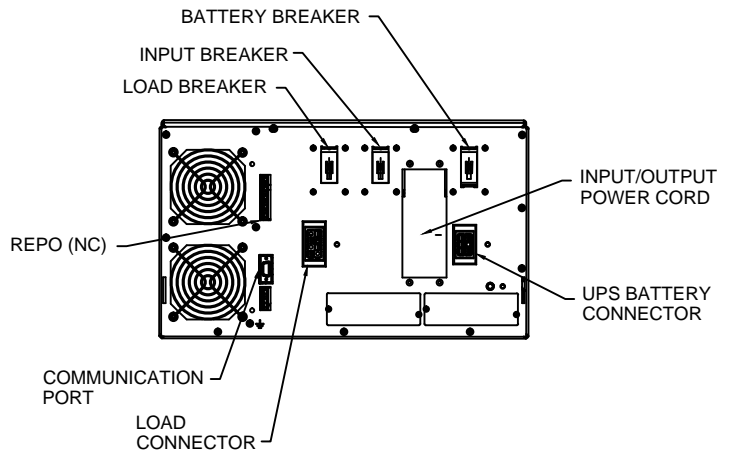

- NOTES
1. FOR OPTIONAL MOUNTING BRACKETS USE SHIPPING BRACKETS.
 2. CENTER OF GRAVITY AND WEIGHT: SEE TABLE
 3. THE SYSTEM MUST BE INSTALLED ON A LEVEL FLOOR SURFACE SUITABLE FOR COMPUTER OR ELECTRONIC EQUIPMENT.
 4. THE SYSTEM MUST BE INSTALLED IN A TEMPERATURE AND HUMIDITY CONTROLLED INDOOR AREA FREE OF CONDUCTIVE CONTAMINANTS.
 5. AMBIENT TEMPERATURE RANGE 0-40°C [32-104°F]; RECOMMENDED OPERATING RANGE: 20-25°C [68-77°F]; MAXIMUM RELATIVE HUMIDITY: 95% NON-CONDENSING.
 6. MINIMUM 900MM [36 IN] FRONT ACCESS AND 900MM [36 IN] REAR ACCESS NEEDED FOR SERVICING.
 7. MINIMUM 400 MM [15.7 IN] CLEARANCE IN REAR, NOT INCLUDING CUSTOMER CONNECTION COVER, IS NEEDED FOR VENTILATION EXHAUST.
 8. MINIMUM 575MM [22.6 IN] CLEARANCE IN FRONT IS NEEDED FOR COOLING AIR INTAKE AND DOOR SWING.
 9. THE UPS CABINET CAN BE INSTALLED IN LINE-UP-AND-MATCH OR STANDALONE CONFIGURATIONS.
 10. BOTTOM OR TOP CABLE ENTRY THROUGH REMOVABLE CONDUIT LANDING PLATE. PLATE SHALL BE CUSTOM MODIFIED TO SUIT CONDUIT SIZES.
 11. ALL WIRING IS TO BE IN ACCORDANCE WITH NATIONAL AND LOCAL ELECTRIC CODES.
 12. AC INPUT TO UPS RECTIFIER (0.98 MIN PF): 3 PHASES, 1 NEUTRAL, 1 GROUND.
AC OUTPUT TO LOAD: 3 PHASES, 1 NEUTRAL, 1 GROUND.
DC INPUT TO UPS (EXTERNAL BATTERY ONLY): 1 POSITIVE, 1 NEGATIVE, 1 GROUND.
 13. SPECIFICATIONS ARE SUBJECT TO CHANGE.

TOP ENTRY

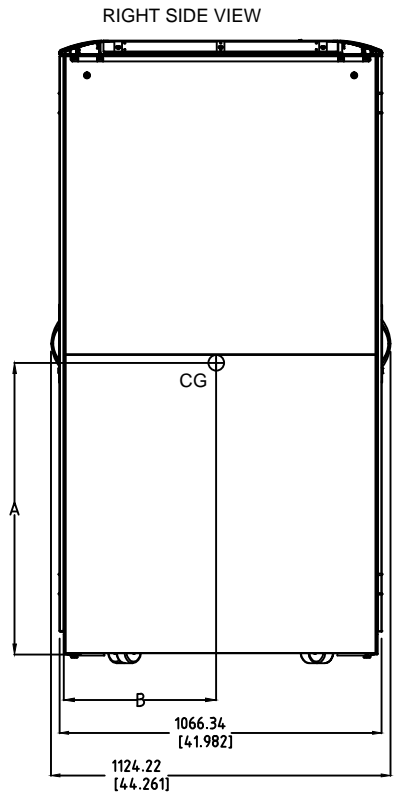
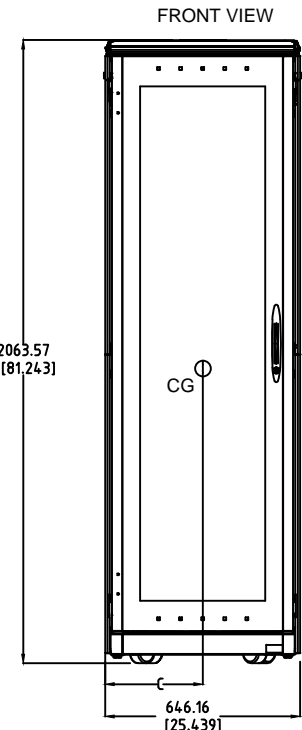

3 HIGH

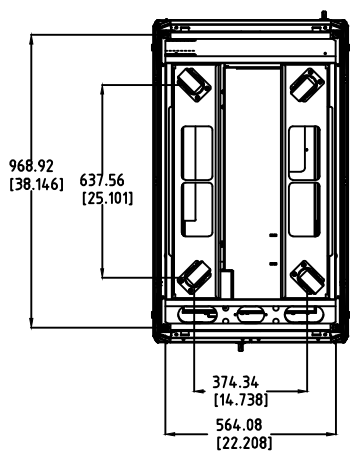
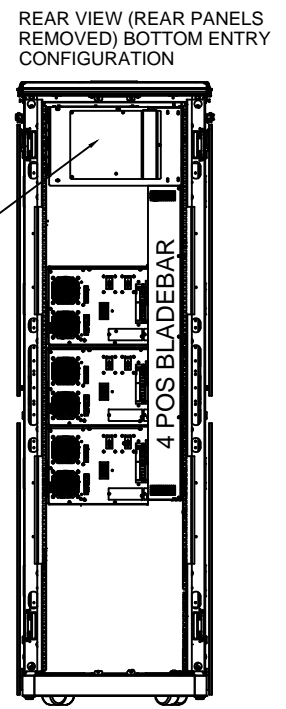
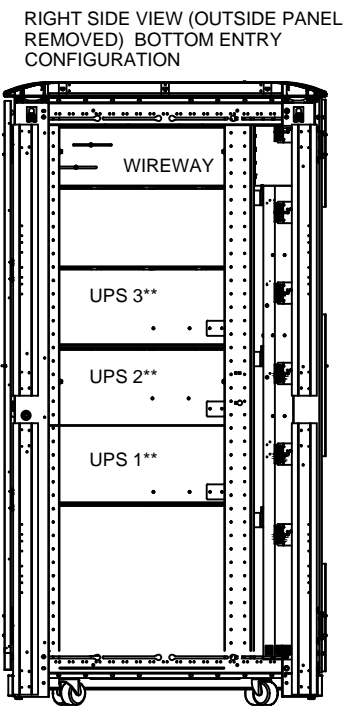

**NOTE: UPS POSITIONS SHOWN ARE REQUIRED FOR ALL CONFIGURATIONS

WEIGHT AND CENTER OF GRAVITY		TOP ENTRY CONFIGURATION		
CONFIGURATION	WEIGHT *	A	B	C
RACK W/ 3 UPS	590.1 kg [1301 lbs]	595 [23.43]	351 [13.82]	227 [8.94]

METRIC	THIRD ANGLE PROJECTION	EATON CORPORATION		EATON	
DIMENSIONS ARE IN MILLIMETERS AFTER PLATING, DIMENSIONS AND TOLERANCES IN ACCORDANCE WITH ASME Y14.5M-1994. SEE NOTES FOR TOLERANCES.					
DESCRIPTION: BLADEUPS SITEPLAN DRW (PRECONFIG-WRIGHTLINE) W/4-POS BLADEBAR (TOP ENTRY)					
ORIGINATED: GOLDEN_D	17-JUL-2012	ECCO:ECO-117817	NAME:	REVISION:04	SIZE: A3
MODIFIED: R. SINGH	23-MAR-2017			STATE:RELEASE	NOT TO SCALE
CHECKED:		DOCUMENT TYPE:	P-110000115-004		SHEET: 2 OF 10
SAFETY:		AUTOCAD DRAWING			
APPROVED:		EATON CORPORATION - CONFIDENTIAL AND PROPRIETARY NOTICE TO PERSONS RECEIVING THIS DOCUMENT AND/OR TECHNICAL INFORMATION			
THIS DOCUMENT, INCLUDING THE DRAWING AND INFORMATION CONTAINED THEREON, IS CONFIDENTIAL AND IS THE EXCLUSIVE PROPERTY OF EATON CORPORATION, AND IS MERELY ON LOAN AND SUBJECT TO RECALL BY EATON AT ANY TIME. BY TAKING POSSESSION OF THIS DOCUMENT, THE RECIPIENT ACKNOWLEDGES AND AGREES THAT THIS DOCUMENT CANNOT BE USED IN ANY MANNER ADVERSE TO THE INTERESTS OF EATON AND THAT NO PORTION OF THIS DOCUMENT MAY BE COPIED OR OTHERWISE REPRODUCED WITHOUT THE PRIOR WRITTEN CONSENT OF EATON. IN THE CASE OF CONFLICTING CONTRACTUAL PROVISIONS, THIS NOTICE SHALL GOVERN THE STATUS OF THIS DOCUMENT. © 2011 Eaton Corporation - All Rights Reserved.					

A3

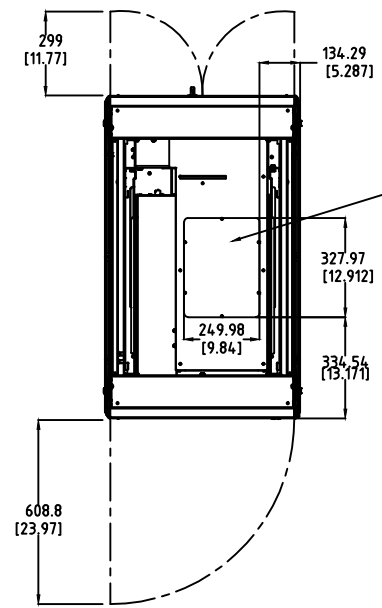

TOP ENTRY CONDUIT LANDING PLATE
(TOP COVER REMOVED FOR CLARITY)

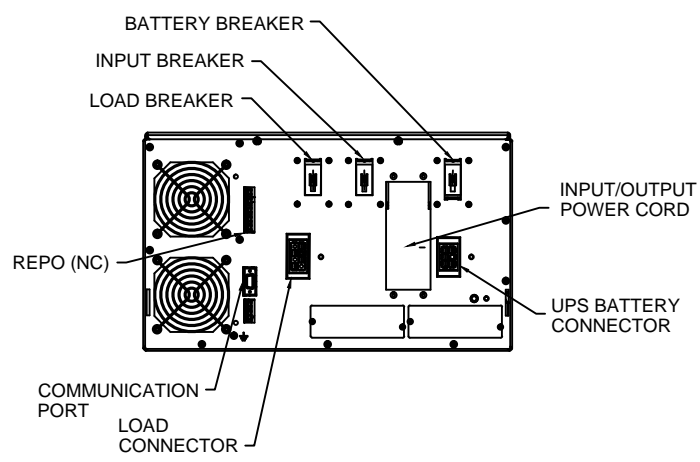

- NOTES
- FOR OPTIONAL MOUNTING BRACKETS USE SHIPPING BRACKETS.
 - CENTER OF GRAVITY AND WEIGHT: SEE TABLE
 - THE SYSTEM MUST BE INSTALLED ON A LEVEL FLOOR SURFACE SUITABLE FOR COMPUTER OR ELECTRONIC EQUIPMENT.
 - THE SYSTEM MUST BE INSTALLED IN A TEMPERATURE AND HUMIDITY CONTROLLED INDOOR AREA FREE OF CONDUCTIVE CONTAMINANTS.
 - AMBIENT TEMPERATURE RANGE 0-40°C [32-104°F]; RECOMMENDED OPERATING RANGE: 20-25°C [68-77°F]; MAXIMUM RELATIVE HUMIDITY: 95% NON-CONDENSING.
 - MINIMUM 900MM [36 IN] FRONT ACCESS AND 900MM [36 IN] REAR ACCESS NEEDED FOR SERVICING.
 - MINIMUM 400 MM [15.7 IN] CLEARANCE IN REAR. NOT INCLUDING CUSTOMER CONNECTION COVER, IS NEEDED FOR VENTILATION EXHAUST.
 - MINIMUM 575MM [22.6 IN] CLEARANCE IN FRONT IS NEEDED FOR COOLING AIR INTAKE AND DOOR SWING.
 - THE UPS CABINET CAN BE INSTALLED IN LINE-UP-AND-MATCH OR STANDALONE CONFIGURATIONS.
 - BOTTOM OR TOP CABLE ENTRY THROUGH REMOVABLE CONDUIT LANDING PLATE. PLATE SHALL BE CUSTOM MODIFIED TO SUIT CONDUIT SIZES.
 - ALL WIRING IS TO BE IN ACCORDANCE WITH NATIONAL AND LOCAL ELECTRIC CODES.
 - AC INPUT TO UPS RECTIFIER (0.98 MIN PF): 3 PHASES, 1 NEUTRAL, 1 GROUND.
AC OUTPUT TO LOAD: 3 PHASES, 1 NEUTRAL, 1 GROUND.
DC INPUT TO UPS (EXTERNAL BATTERY ONLY): 1 POSITIVE, 1 NEGATIVE, 1 GROUND.
 - SPECIFICATIONS ARE SUBJECT TO CHANGE.

TOP ENTRY

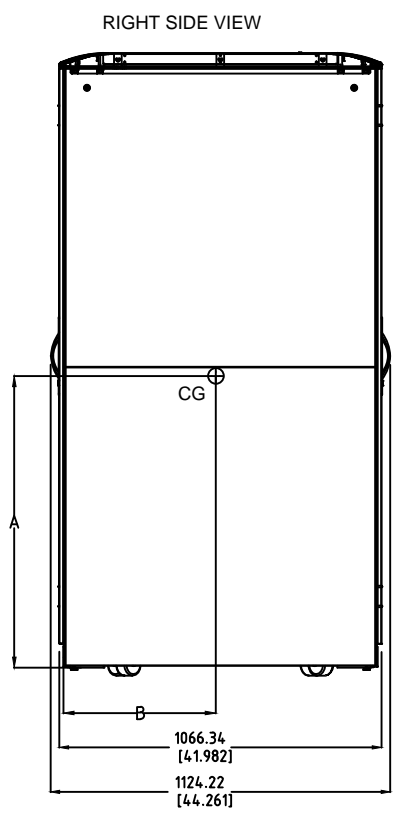
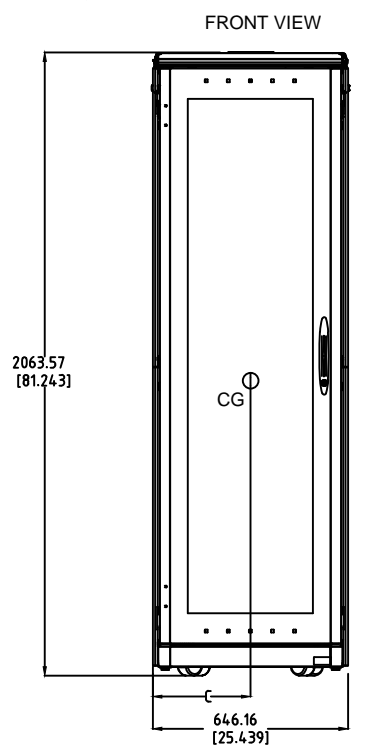

2 HIGH

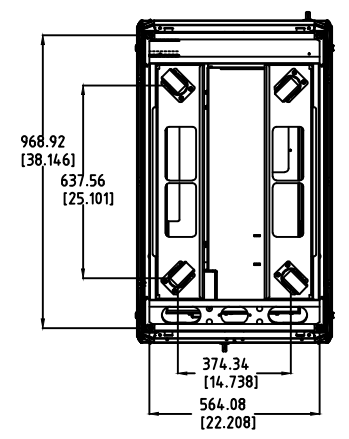
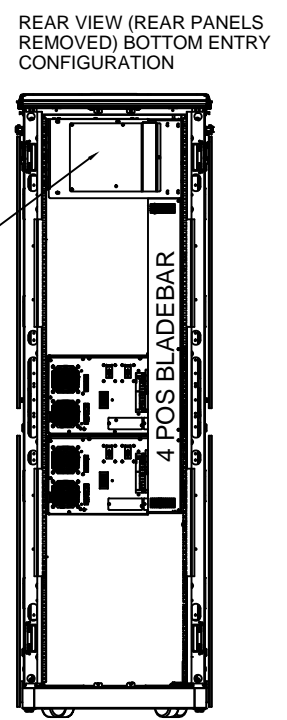
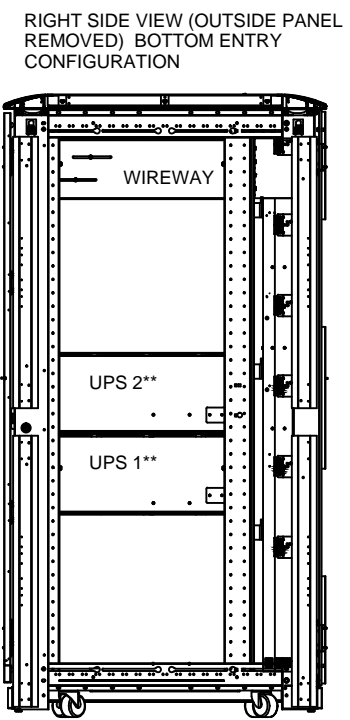

**NOTE: UPS POSITIONS SHOWN ARE REQUIRED FOR ALL CONFIGURATIONS

WEIGHT AND CENTER OF GRAVITY		TOP ENTRY CONFIGURATION		
CONFIGURATION	WEIGHT *	A	B	C
RACK W/ 2 UPS	444.1 kg [979 lbs]	572 [22.52]	371 [14.61]	228 [8.98]

METRIC	THIRD ANGLE PROJECTION	EATON CORPORATION		EATON	
DIMENSIONS ARE IN MILLIMETERS AFTER PLATING, DIMENSIONS AND TOLERANCES IN ACCORDANCE WITH ASME Y14.5M-1994. SEE NOTES FOR TOLERANCES.					
DESCRIPTION: BLADEUPS SITEPLAN DRW (PRECONFIG-WRIGHTLINE) W/4-POS BLADEBAR (TOP ENTRY)					
ORIGINATED: GOLDEN_D	17-JUL-2012	ECCO:ECO-117817	NAME:	REVISION:04	SIZE: A3
MODIFIED: R. SINGH	23-MAR-2017		P-110000115-004	STATE:RELEASE	NOT TO SCALE
CHECKED:		DOCUMENT TYPE:			SHEET: 3 OF 10
SAFETY:		AUTOCAD DRAWING			
APPROVED:					
EATON CORPORATION - CONFIDENTIAL AND PROPRIETARY NOTICE TO PERSONS RECEIVING THIS DOCUMENT AND/OR TECHNICAL INFORMATION THIS DOCUMENT, INCLUDING THE DRAWING AND INFORMATION CONTAINED THEREON, IS CONFIDENTIAL AND IS THE EXCLUSIVE PROPERTY OF EATON CORPORATION, AND IS MERELY ON LOAN AND SUBJECT TO RECALL BY EATON AT ANY TIME. BY TAKING POSSESSION OF THIS DOCUMENT, THE RECIPIENT ACKNOWLEDGES AND AGREES THAT THIS DOCUMENT CANNOT BE USED IN ANY MANNER ADVERSE TO THE INTERESTS OF EATON AND THAT NO PORTION OF THIS DOCUMENT MAY BE COPIED OR OTHERWISE REPRODUCED WITHOUT THE PRIOR WRITTEN CONSENT OF EATON. IN THE CASE OF CONFLICTING CONTRACTUAL PROVISIONS, THIS NOTICE SHALL GOVERN THE STATUS OF THIS DOCUMENT. © 2011 Eaton Corporation - All Rights Reserved.					

A3

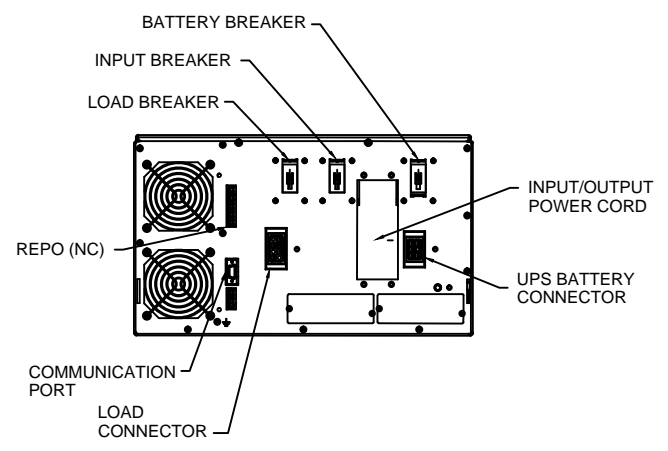
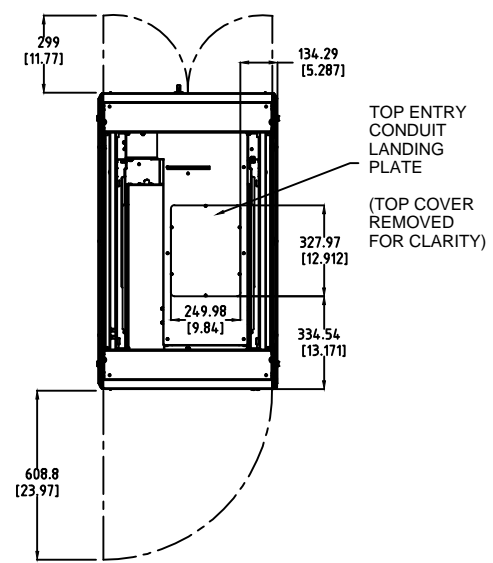

- NOTES**
- FOR OPTIONAL MOUNTING BRACKETS USE SHIPPING BRACKETS.
 - CENTER OF GRAVITY AND WEIGHT: SEE TABLE
 - THE SYSTEM MUST BE INSTALLED ON A LEVEL FLOOR SURFACE SUITABLE FOR COMPUTER OR ELECTRONIC EQUIPMENT.
 - THE SYSTEM MUST BE INSTALLED IN A TEMPERATURE AND HUMIDITY CONTROLLED INDOOR AREA FREE OF CONDUCTIVE CONTAMINANTS.
 - AMBIENT TEMPERATURE RANGE 0-40°C [32-104°F]; RECOMMENDED OPERATING RANGE: 20-25°C [68-77°F]; MAXIMUM RELATIVE HUMIDITY: 95% NON-CONDENSING.
 - MINIMUM 900MM [36 IN] FRONT ACCESS AND 900MM [36 IN] REAR ACCESS NEEDED FOR SERVICING.
 - MINIMUM 400 MM [15.7 IN] CLEARANCE IN REAR, NOT INCLUDING CUSTOMER CONNECTION COVER, IS NEEDED FOR VENTILATION EXHAUST.
 - MINIMUM 575MM [22.6 IN] CLEARANCE IN FRONT IS NEEDED FOR COOLING AIR INTAKE AND DOOR SWING.
 - THE UPS CABINET CAN BE INSTALLED IN LINE-UP-AND-MATCH OR STANDALONE CONFIGURATIONS.
 - BOTTOM OR TOP CABLE ENTRY THROUGH REMOVABLE CONDUIT LANDING PLATE. PLATE SHALL BE CUSTOM MODIFIED TO SUIT CONDUIT SIZES.
 - ALL WIRING IS TO BE IN ACCORDANCE WITH NATIONAL AND LOCAL ELECTRIC CODES.
 - AC INPUT TO UPS RECTIFIER (0.98 MIN PF): 3 PHASES, 1 NEUTRAL, 1 GROUND. AC OUTPUT TO LOAD: 3 PHASES, 1 NEUTRAL, 1 GROUND.
 - DC INPUT TO UPS (EXTERNAL BATTERY ONLY): 1 POSITIVE, 1 NEGATIVE, 1 GROUND.
 - SPECIFICATIONS ARE SUBJECT TO CHANGE.

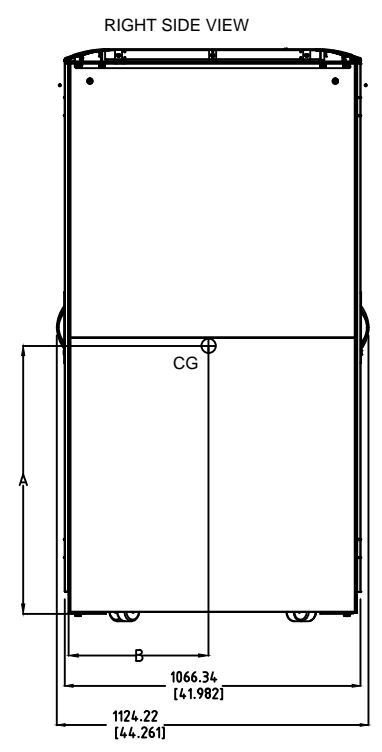
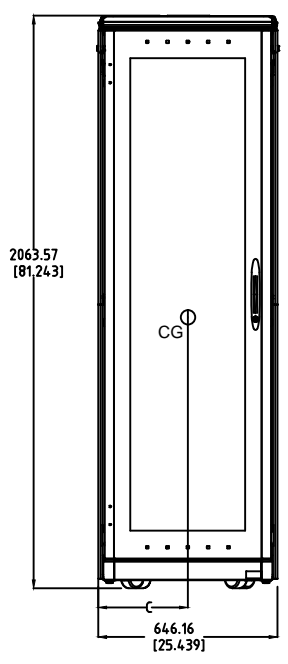

1 HIGH

RIGHT SIDE VIEW (OUTSIDE PANEL REMOVED) BOTTOM ENTRY CONFIGURATION

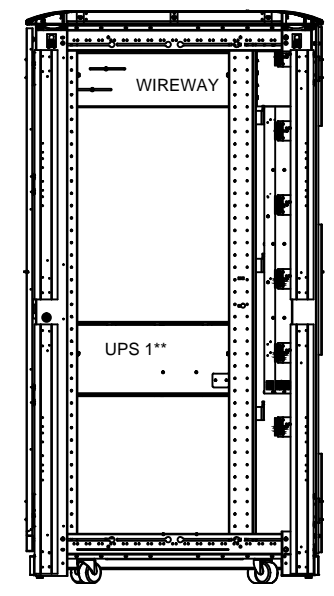

TOP ENTRY

REAR VIEW (REAR PANELS REMOVED) BOTTOM ENTRY CONFIGURATION

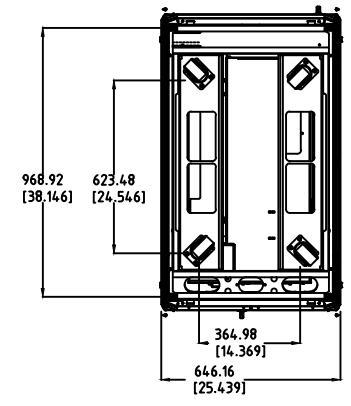
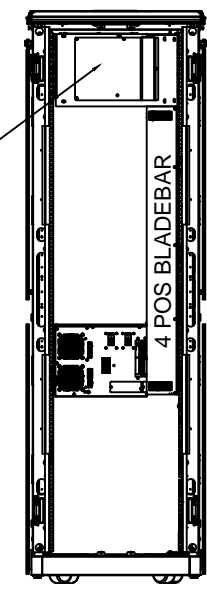

**NOTE: UPS POSITIONS SHOWN ARE REQUIRED FOR ALL CONFIGURATIONS

WEIGHT AND CENTER OF GRAVITY		TOP ENTRY CONFIGURATION		
CONFIGURATION	WEIGHT *	A	B	C
RACK W/ 1 UPS	298.0 kg [657 lbs]	655 [25.79]	410 [16.14]	230 [9.06]

METRIC	THIRD ANGLE PROJECTION	EATON CORPORATION		EATON	
DIMENSIONS ARE IN MILLIMETERS AFTER PLATING, DIMENSIONS AND TOLERANCES IN ACCORDANCE WITH ASME Y14.5M-1994. SEE NOTES FOR TOLERANCES.					
DESCRIPTION: BLADEUPS SITEPLAN DRW (PRECONFIG-WRIGHTLINE) W/4-POS BLADEBAR (TOP ENTRY)					
ORIGINATED: GOLDEN_D	17-JUL-2012	ECCO:ECO-117817	NAME:	REVISION:04	SIZE: A3
MODIFIED: R. SINGH	23-MAR-2017			STATE:RELEASE	NOT TO SCALE
CHECKED:		DOCUMENT TYPE:	P-110000115-004		SHEET: 4 OF 10
SAFETY:		AUTOCAD DRAWING			
APPROVED:		EATON CORPORATION - CONFIDENTIAL AND PROPRIETARY NOTICE TO PERSONS RECEIVING THIS DOCUMENT AND/OR TECHNICAL INFORMATION			
THIS DOCUMENT, INCLUDING THE DRAWING AND INFORMATION CONTAINED THEREON, IS CONFIDENTIAL AND IS THE EXCLUSIVE PROPERTY OF EATON CORPORATION, AND IS MERELY ON LOAN AND SUBJECT TO RECALL BY EATON AT ANY TIME. BY TAKING POSSESSION OF THIS DOCUMENT, THE RECIPIENT ACKNOWLEDGES AND AGREES THAT THIS DOCUMENT CANNOT BE USED IN ANY MANNER ADVERSE TO THE INTERESTS OF EATON AND THAT NO PORTION OF THIS DOCUMENT MAY BE COPIED OR OTHERWISE REPRODUCED WITHOUT THE PRIOR WRITTEN CONSENT OF EATON. IN THE CASE OF CONFLICTING CONTRACTUAL PROVISIONS, THIS NOTICE SHALL GOVERN THE STATUS OF THIS DOCUMENT. © 2011 Eaton Corporation - All Rights Reserved.					

A3

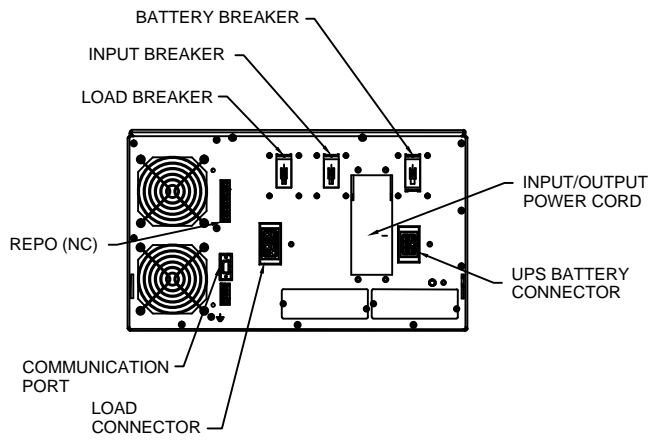
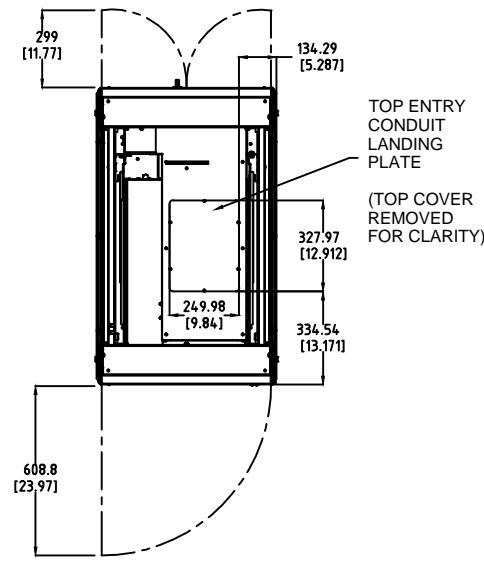

- NOTES**
- FOR OPTIONAL MOUNTING BRACKETS USE SHIPPING BRACKETS.
 - CENTER OF GRAVITY AND WEIGHT: SEE TABLE
 - THE SYSTEM MUST BE INSTALLED ON A LEVEL FLOOR SURFACE SUITABLE FOR COMPUTER OR ELECTRONIC EQUIPMENT.
 - THE SYSTEM MUST BE INSTALLED IN A TEMPERATURE AND HUMIDITY CONTROLLED INDOOR AREA FREE OF CONDUCTIVE CONTAMINANTS.
 - AMBIENT TEMPERATURE RANGE 0-40°C [32-104°F]; RECOMMENDED OPERATING RANGE: 20-25°C [68-77°F]; MAXIMUM RELATIVE HUMIDITY: 95% NON-CONDENSING.
 - MINIMUM 900MM [36 IN] FRONT ACCESS AND 900MM [36 IN] REAR ACCESS NEEDED FOR SERVICING.
 - MINIMUM 400 MM [15.7 IN] CLEARANCE IN REAR, NOT INCLUDING CUSTOMER CONNECTION COVER, IS NEEDED FOR VENTILATION EXHAUST.
 - MINIMUM 575MM [22.6 IN] CLEARANCE IN FRONT IS NEEDED FOR COOLING AIR INTAKE AND DOOR SWING.
 - THE UPS CABINET CAN BE INSTALLED IN LINE-UP-AND-MATCH OR STANDALONE CONFIGURATIONS.
 - BOTTOM OR TOP CABLE ENTRY THROUGH REMOVABLE CONDUIT LANDING PLATE. PLATE SHALL BE CUSTOM MODIFIED TO SUIT CONDUIT SIZES.
 - ALL WIRING IS TO BE IN ACCORDANCE WITH NATIONAL AND LOCAL ELECTRIC CODES.
 - AC INPUT TO UPS RECTIFIER (0.98 MIN PF): 3 PHASES, 1 NEUTRAL, 1 GROUND.
AC OUTPUT TO LOAD: 3 PHASES, 1 NEUTRAL, 1 GROUND.
DC INPUT TO UPS (EXTERNAL BATTERY ONLY): 1 POSITIVE, 1 NEGATIVE, 1 GROUND.
 - SPECIFICATIONS ARE SUBJECT TO CHANGE.

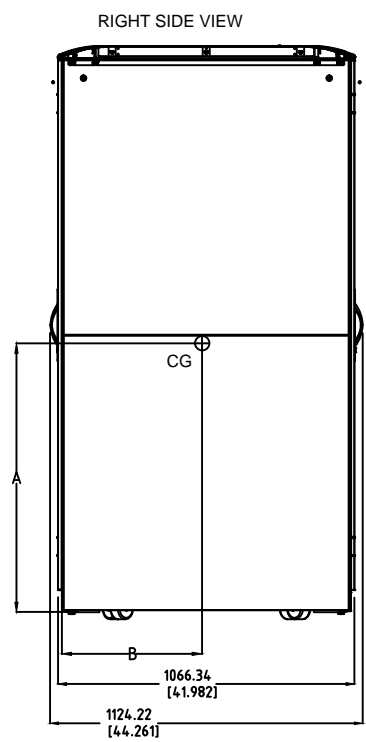
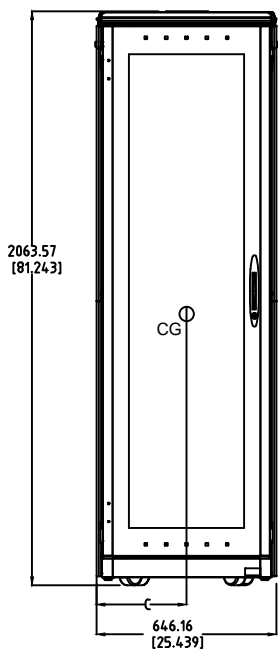

0 HIGH

RIGHT SIDE VIEW (OUTSIDE PANEL REMOVED) BOTTOM ENTRY CONFIGURATION

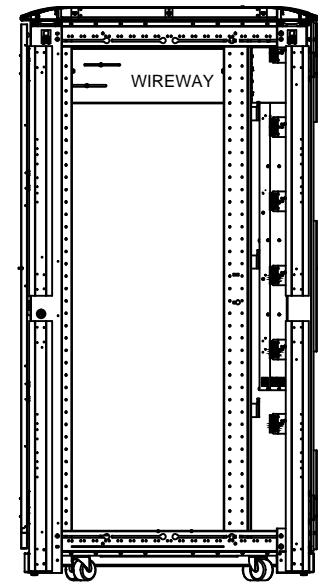

REAR VIEW (REAR PANELS REMOVED) BOTTOM ENTRY CONFIGURATION

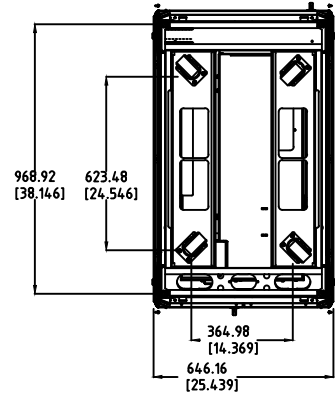
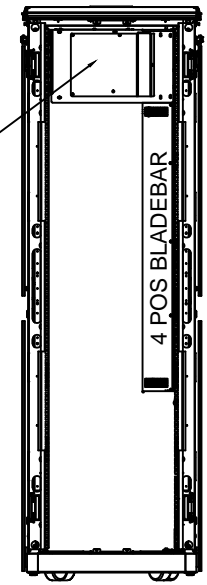

**NOTE: UPS POSITIONS SHOWN ARE REQUIRED FOR ALL CONFIGURATIONS

WEIGHT AND CENTER OF GRAVITY		TOP ENTRY CONFIGURATION		
CONFIGURATION	WEIGHT *	A	B	C
RACK W/ 0 UPS	151.9 kg [335 lbs]	1080 [42.51]	521 [20.51]	236 [9.29]

METRIC		EATON CORPORATION		
DIMENSIONS ARE IN MILLIMETERS AFTER PLATING, DIMENSIONS AND TOLERANCES IN ACCORDANCE WITH ASME Y14.5M-1994. SEE NOTES FOR TOLERANCES.				
DESCRIPTION: BLADEUPS SITEPLAN DRW (PRECONFIG-WRIGHTLINE) W/4-POS BLADEBAR (TOP ENTRY)				
ORIGINATED: GOLDEN_D	17-JUL-2012	ECCO:ECO-117817	NAME:	REVISION:04
MODIFIED: R. SINGH	23-MAR-2017		STATE:RELEASE	SIZE: A3
CHECKED:		DOCUMENT TYPE:	P-110000115-004	NOT TO SCALE
SAFETY:		AUTOCAD DRAWING		SHEET: 5 OF 10
APPROVED:				
EATON CORPORATION - CONFIDENTIAL AND PROPRIETARY NOTICE TO PERSONS RECEIVING THIS DOCUMENT AND/OR TECHNICAL INFORMATION THIS DOCUMENT, INCLUDING THE DRAWING AND INFORMATION CONTAINED THEREON, IS CONFIDENTIAL AND IS THE EXCLUSIVE PROPERTY OF EATON CORPORATION, AND IS MERELY ON LOAN AND SUBJECT TO RECALL BY EATON AT ANY TIME. BY TAKING POSSESSION OF THIS DOCUMENT, THE RECIPIENT ACKNOWLEDGES AND AGREES THAT THIS DOCUMENT CANNOT BE USED IN ANY MANNER ADVERSE TO THE INTERESTS OF EATON AND THAT NO PORTION OF THIS DOCUMENT MAY BE COPIED OR OTHERWISE REPRODUCED WITHOUT THE PRIOR WRITTEN CONSENT OF EATON. IN THE CASE OF CONFLICTING CONTRACTUAL PROVISIONS, THIS NOTICE SHALL GOVERN THE STATUS OF THIS DOCUMENT. © 2011 Eaton Corporation - All Rights Reserved.				

A3

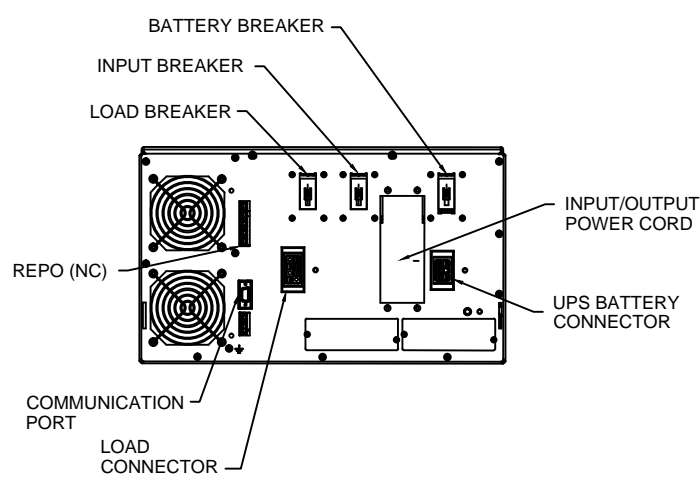
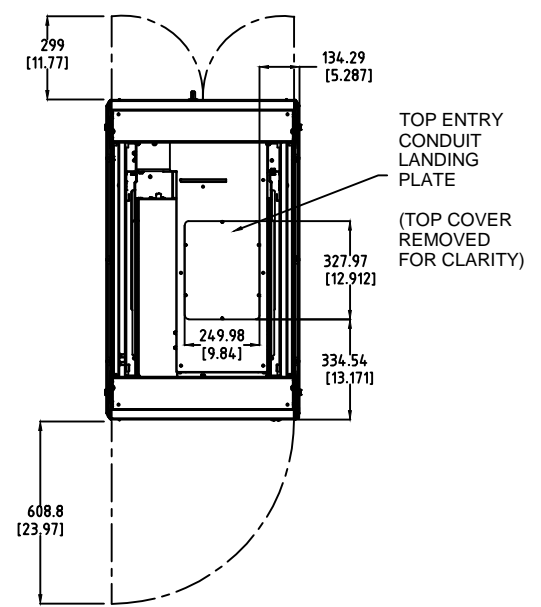

- NOTES
- FOR OPTIONAL MOUNTING BRACKETS USE SHIPPING BRACKETS.
 - CENTER OF GRAVITY AND WEIGHT: SEE TABLE
 - THE SYSTEM MUST BE INSTALLED ON A LEVEL FLOOR SURFACE SUITABLE FOR COMPUTER OR ELECTRONIC EQUIPMENT.
 - THE SYSTEM MUST BE INSTALLED IN A TEMPERATURE AND HUMIDITY CONTROLLED INDOOR AREA FREE OF CONDUCTIVE CONTAMINANTS.
 - AMBIENT TEMPERATURE RANGE 0-40°C [32-104°F]; RECOMMENDED OPERATING RANGE: 20-25°C [68-77°F]; MAXIMUM RELATIVE HUMIDITY: 95% NON-CONDENSING.
 - MINIMUM 900MM [36 IN] FRONT ACCESS AND 900MM [36 IN] REAR ACCESS NEEDED FOR SERVICING.
 - MINIMUM 400 MM [15.7 IN] CLEARANCE IN REAR, NOT INCLUDING CUSTOMER CONNECTION COVER, IS NEEDED FOR VENTILATION EXHAUST.
 - MINIMUM 575MM [22.6 IN] CLEARANCE IN FRONT IS NEEDED FOR COOLING AIR INTAKE AND DOOR SWING.
 - THE UPS CABINET CAN BE INSTALLED IN LINE-UP-AND-MATCH OR STANDALONE CONFIGURATIONS.
 - BOTTOM OR TOP CABLE ENTRY THROUGH REMOVABLE CONDUIT LANDING PLATE. PLATE SHALL BE CUSTOM MODIFIED TO SUIT CONDUIT SIZES.
 - ALL WIRING IS TO BE IN ACCORDANCE WITH NATIONAL AND LOCAL ELECTRIC CODES.
 - AC INPUT TO UPS RECTIFIER (0.98 MIN PF): 3 PHASES, 1 NEUTRAL, 1 GROUND.
AC OUTPUT TO LOAD: 3 PHASES, 1 NEUTRAL, 1 GROUND.
DC INPUT TO UPS (EXTERNAL BATTERY ONLY): 1 POSITIVE, 1 NEGATIVE, 1 GROUND.
 - SPECIFICATIONS ARE SUBJECT TO CHANGE.

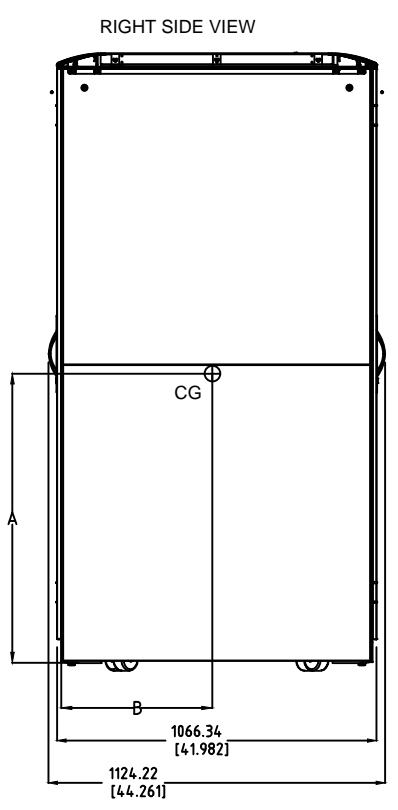
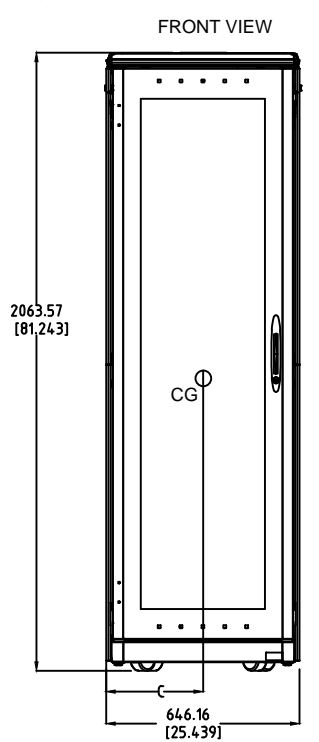

4 HIGH WITH MBM

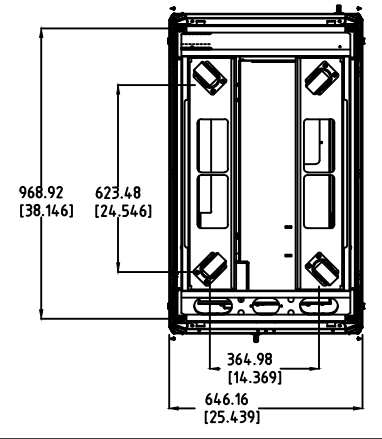
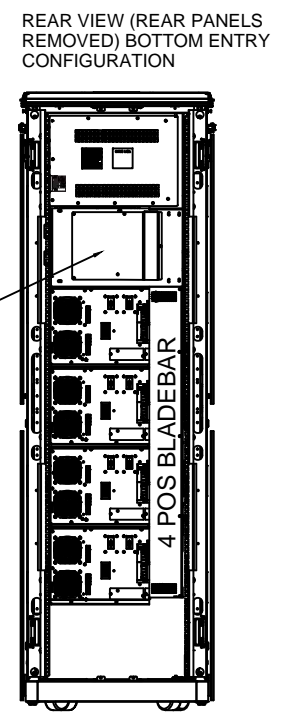
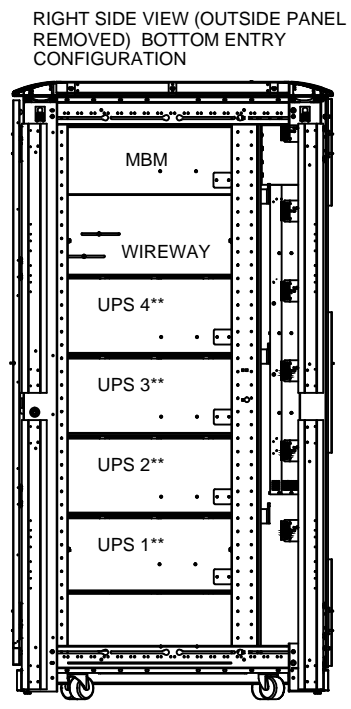

**NOTE: UPS POSITIONS SHOWN ARE REQUIRED FOR ALL CONFIGURATIONS

WEIGHT AND CENTER OF GRAVITY		TOP ENTRY CONFIGURATION		
CONFIGURATION	WEIGHT *	A	B	C
RACK W/ 4 UPS WITH MBM	781.5 kg [1723 lbs]	969 [38.15]	331 [13.03]	232 [9.13]

METRIC	THIRD ANGLE PROJECTION	EATON CORPORATION		EATON	
DIMENSIONS ARE IN MILLIMETERS AFTER PLATING, DIMENSIONS AND TOLERANCES IN ACCORDANCE WITH ASME Y14.5M-1994. SEE NOTES FOR TOLERANCES.					
DESCRIPTION: BLADEUPS SITEPLAN DRW (PRECONFIG-WRIGHTLINE) W/4-POS BLADEBAR (TOP ENTRY)					
ORIGINATED: GOLDEN_D	17-JUL-2012	ECCO:ECO-117817	NAME:	REVISION:04	SIZE: A3
MODIFIED: R. SINGH	23-MAR-2017		P-110000115-004	STATE:RELEASE	NOT TO SCALE
CHECKED:		DOCUMENT TYPE:	AUTOCAD DRAWING		SHEET: 6 OF 10
SAFETY:					
APPROVED:					
EATON CORPORATION - CONFIDENTIAL AND PROPRIETARY NOTICE TO PERSONS RECEIVING THIS DOCUMENT AND/OR TECHNICAL INFORMATION THIS DOCUMENT, INCLUDING THE DRAWING AND INFORMATION CONTAINED THEREON, IS CONFIDENTIAL AND IS THE EXCLUSIVE PROPERTY OF EATON CORPORATION, AND IS MERELY ON LOAN AND SUBJECT TO RECALL BY EATON AT ANY TIME. BY TAKING POSSESSION OF THIS DOCUMENT, THE RECIPIENT ACKNOWLEDGES AND AGREES THAT THIS DOCUMENT CANNOT BE USED IN ANY MANNER ADVERSE TO THE INTERESTS OF EATON AND THAT NO PORTION OF THIS DOCUMENT MAY BE COPIED OR OTHERWISE REPRODUCED WITHOUT THE PRIOR WRITTEN CONSENT OF EATON. IN THE CASE OF CONFLICTING CONTRACTUAL PROVISIONS, THIS NOTICE SHALL GOVERN THE STATUS OF THIS DOCUMENT. © 2011 Eaton Corporation - All Rights Reserved.					

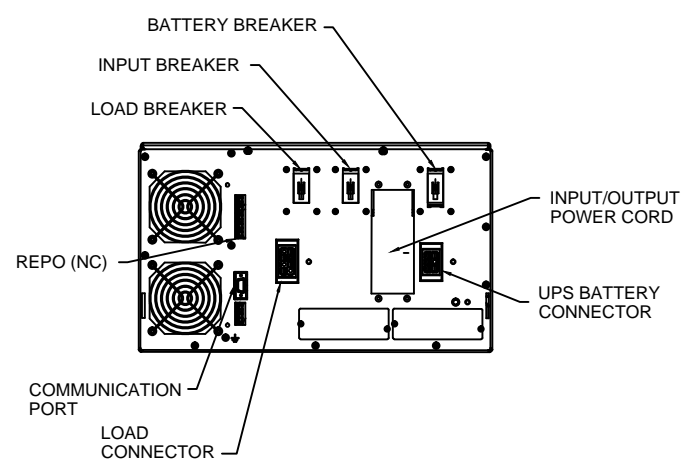
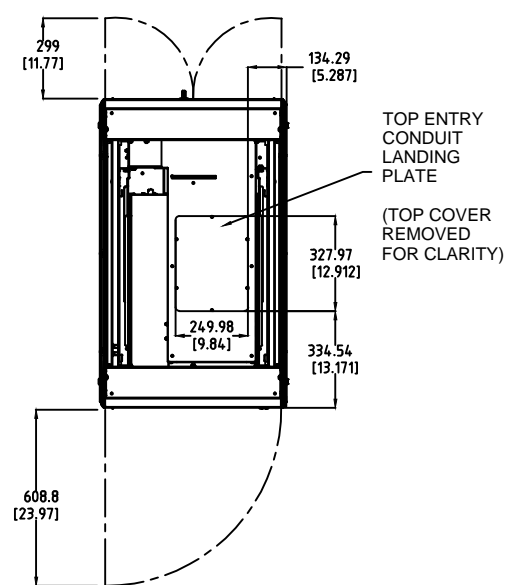

- NOTES
- FOR OPTIONAL MOUNTING BRACKETS USE SHIPPING BRACKETS.
 - CENTER OF GRAVITY AND WEIGHT: SEE TABLE
 - THE SYSTEM MUST BE INSTALLED ON A LEVEL FLOOR SURFACE SUITABLE FOR COMPUTER OR ELECTRONIC EQUIPMENT.
 - THE SYSTEM MUST BE INSTALLED IN A TEMPERATURE AND HUMIDITY CONTROLLED INDOOR AREA FREE OF CONDUCTIVE CONTAMINANTS.
 - AMBIENT TEMPERATURE RANGE 0-40°C [32-104°F]; RECOMMENDED OPERATING RANGE: 20-25°C [68-77°F]; MAXIMUM RELATIVE HUMIDITY: 95% NON-CONDENSING.
 - MINIMUM 900MM [36 IN] FRONT ACCESS AND 900MM [36 IN] REAR ACCESS NEEDED FOR SERVICING.
 - MINIMUM 400 MM [15.7 IN] CLEARANCE IN REAR, NOT INCLUDING CUSTOMER CONNECTION COVER, IS NEEDED FOR VENTILATION EXHAUST.
 - MINIMUM 575MM [22.6 IN] CLEARANCE IN FRONT IS NEEDED FOR COOLING AIR INTAKE AND DOOR SWING.
 - THE UPS CABINET CAN BE INSTALLED IN LINE-UP-AND-MATCH OR STANDALONE CONFIGURATIONS.
 - BOTTOM OR TOP CABLE ENTRY THROUGH REMOVABLE CONDUIT LANDING PLATE. PLATE SHALL BE CUSTOM MODIFIED TO SUIT CONDUIT SIZES.
 - ALL WIRING IS TO BE IN ACCORDANCE WITH NATIONAL AND LOCAL ELECTRIC CODES.
 - AC INPUT TO UPS RECTIFIER (0.98 MIN PF): 3 PHASES, 1 NEUTRAL, 1 GROUND.
AC OUTPUT TO LOAD: 3 PHASES, 1 NEUTRAL, 1 GROUND.
DC INPUT TO UPS (EXTERNAL BATTERY ONLY): 1 POSITIVE, 1 NEGATIVE, 1 GROUND.
 - SPECIFICATIONS ARE SUBJECT TO CHANGE.

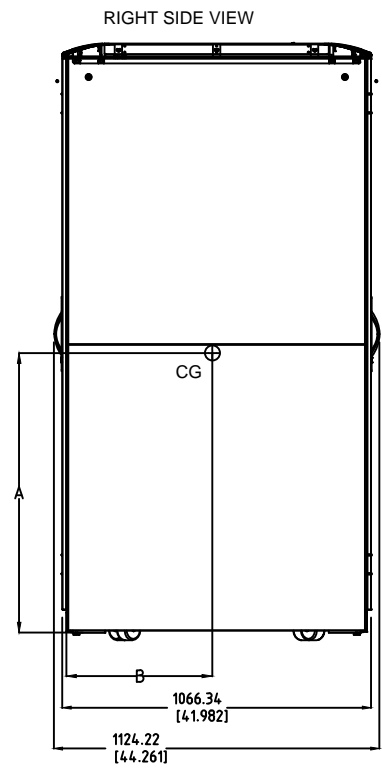
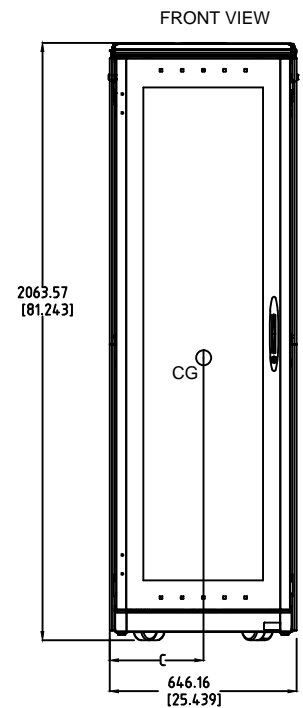

3 HIGH WITH MBM

TOP ENTRY

RIGHT SIDE VIEW (OUTSIDE PANEL REMOVED) BOTTOM ENTRY CONFIGURATION

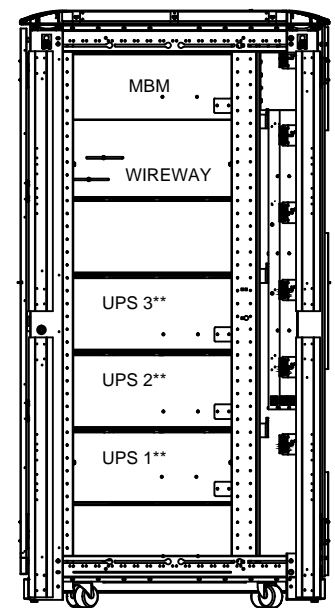

REAR VIEW (REAR PANELS REMOVED) BOTTOM ENTRY CONFIGURATION

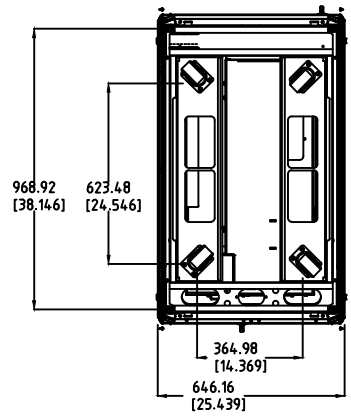
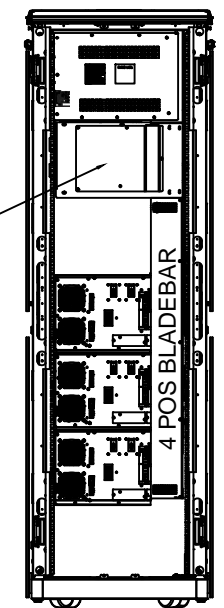

**NOTE: UPS POSITIONS SHOWN ARE REQUIRED FOR ALL CONFIGURATIONS

CONFIGURATION	WEIGHT *	TOP ENTRY CONFIGURATION		
		A	B	C
RACK W/ 3 UPS WITH MBM	635.4 kg [1401 lbs]	897 [35.31]	341 [13.42]	234 [9.21]

METRIC	THIRD ANGLE PROJECTION	EATON CORPORATION		EATON	
DIMENSIONS ARE IN MILLIMETERS AFTER PLATING, DIMENSIONS AND TOLERANCES IN ACCORDANCE WITH ASME Y14.5M-1994. SEE NOTES FOR TOLERANCES.					
DESCRIPTION: BLADEUPS SITEPLAN DRW (PRECONFIG-WRIGHTLINE) W/4-POS BLADEBAR (TOP ENTRY)					
ORIGINATED: GOLDEN_D	17-JUL-2012	ECCO:ECCO-117817	NAME:	REVISION:04	SIZE: A3
MODIFIED: R. SINGH	23-MAR-2017		DOCUMENT TYPE: P-110000115-004	STATE:RELEASE	NOT TO SCALE
CHECKED:					SHEET: 7 OF 10
SAFETY:					
APPROVED:					
EATON CORPORATION - CONFIDENTIAL AND PROPRIETARY NOTICE TO PERSONS RECEIVING THIS DOCUMENT AND/OR TECHNICAL INFORMATION THIS DOCUMENT, INCLUDING THE DRAWING AND INFORMATION CONTAINED THEREON, IS CONFIDENTIAL AND IS THE EXCLUSIVE PROPERTY OF EATON CORPORATION, AND IS MERELY ON LOAN AND SUBJECT TO RECALL BY EATON AT ANY TIME. BY TAKING POSSESSION OF THIS DOCUMENT, THE RECIPIENT ACKNOWLEDGES AND AGREES THAT THIS DOCUMENT CANNOT BE USED IN ANY MANNER ADVERSE TO THE INTERESTS OF EATON AND THAT NO PORTION OF THIS DOCUMENT MAY BE COPIED OR OTHERWISE REPRODUCED WITHOUT THE PRIOR WRITTEN CONSENT OF EATON. IN THE CASE OF CONFLICTING CONTRACTUAL PROVISIONS, THIS NOTICE SHALL GOVERN THE STATUS OF THIS DOCUMENT. © 2011 Eaton Corporation - All Rights Reserved.					

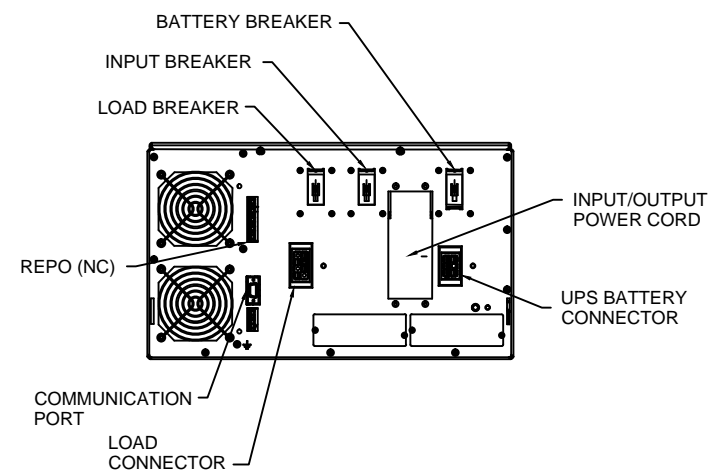
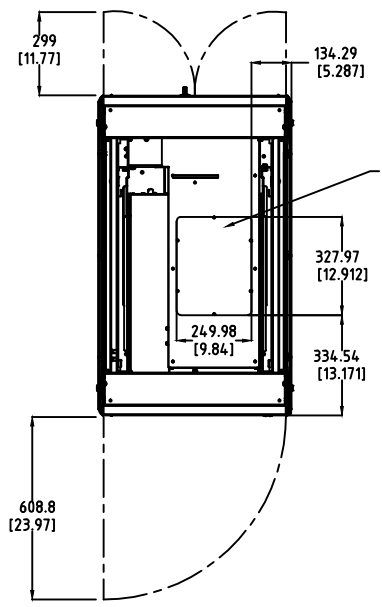

- NOTES
1. FOR OPTIONAL MOUNTING BRACKETS USE SHIPPING BRACKETS.
 2. CENTER OF GRAVITY AND WEIGHT: SEE TABLE
 3. THE SYSTEM MUST BE INSTALLED ON A LEVEL FLOOR SURFACE SUITABLE FOR COMPUTER OR ELECTRONIC EQUIPMENT.
 4. THE SYSTEM MUST BE INSTALLED IN A TEMPERATURE AND HUMIDITY CONTROLLED INDOOR AREA FREE OF CONDUCTIVE CONTAMINANTS.
 5. AMBIENT TEMPERATURE RANGE 0-40°C [32-104°F]; RECOMMENDED OPERATING RANGE: 20-25°C [68-77°F]; MAXIMUM RELATIVE HUMIDITY: 95% NON-CONDENSING.
 6. MINIMUM 900MM [36 IN] FRONT ACCESS AND 900MM [36 IN] REAR ACCESS NEEDED FOR SERVICING.
 7. MINIMUM 400 MM [15.7 IN] CLEARANCE IN REAR, NOT INCLUDING CUSTOMER CONNECTION COVER, IS NEEDED FOR VENTILATION EXHAUST.
 8. MINIMUM 575MM [22.6 IN] CLEARANCE IN FRONT IS NEEDED FOR COOLING AIR INTAKE AND DOOR SWING.
 9. THE UPS CABINET CAN BE INSTALLED IN LINE-UP-AND-MATCH OR STANDALONE CONFIGURATIONS.
 10. BOTTOM OR TOP CABLE ENTRY THROUGH REMOVABLE CONDUIT LANDING PLATE. PLATE SHALL BE CUSTOM MODIFIED TO SUIT CONDUIT SIZES.
 11. ALL WIRING IS TO BE IN ACCORDANCE WITH NATIONAL AND LOCAL ELECTRIC CODES.
 12. AC INPUT TO UPS RECTIFIER (0.98 MIN PF): 3 PHASES, 1 NEUTRAL, 1 GROUND.
AC OUTPUT TO LOAD: 3 PHASES, 1 NEUTRAL, 1 GROUND.
DC INPUT TO UPS (EXTERNAL BATTERY ONLY): 1 POSITIVE, 1 NEGATIVE, 1 GROUND.
 13. SPECIFICATIONS ARE SUBJECT TO CHANGE.

FRONT VIEW

RIGHT SIDE VIEW

2 HIGH WITH MBM

TOP ENTRY

RIGHT SIDE VIEW (OUTSIDE PANEL REMOVED) BOTTOM ENTRY CONFIGURATION

REAR VIEW (REAR PANELS REMOVED) BOTTOM ENTRY CONFIGURATION

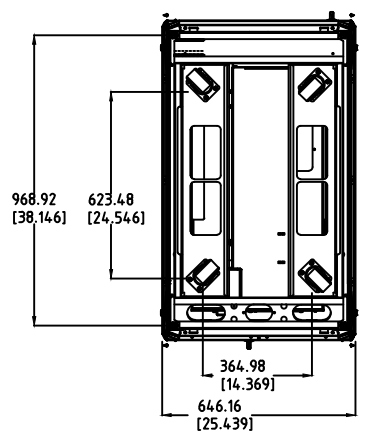
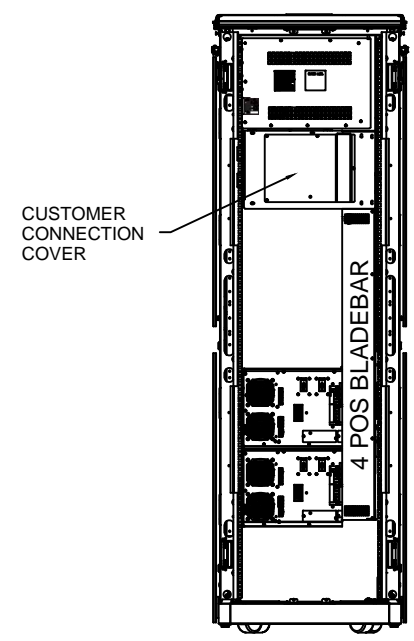
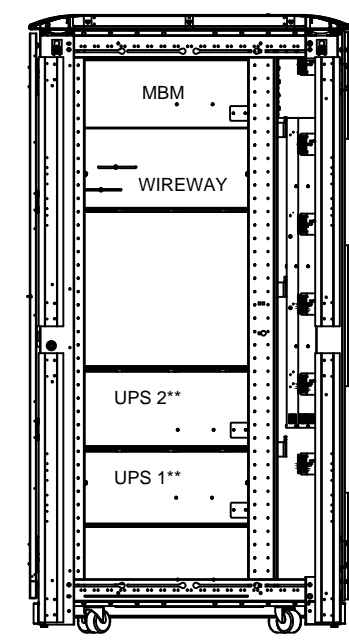
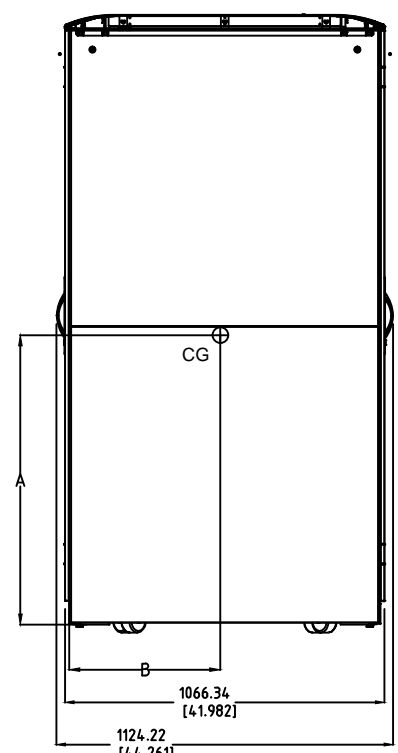
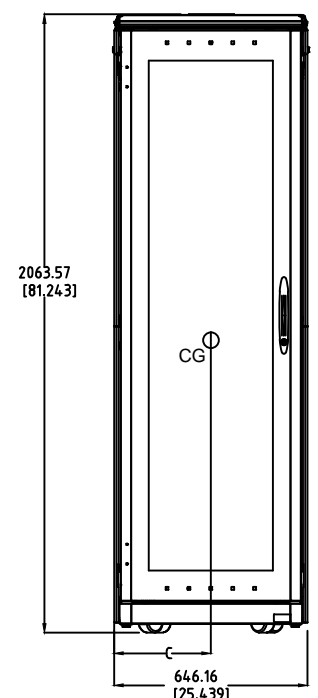

**NOTE: UPS POSITIONS SHOWN ARE REQUIRED FOR ALL CONFIGURATIONS

WEIGHT AND CENTER OF GRAVITY CONFIGURATION	WEIGHT *	TOP ENTRY CONFIGURATION		
		A	B	C
RACK W/ 2 UPS WITH MBM	489.4 kg [1079 lbs]	863 [33.98]	356 [14.01]	237 [9.33]

METRIC	THIRD ANGLE PROJECTION	EATON CORPORATION		EATON	
DIMENSIONS ARE IN MILLIMETERS AFTER PLATING, DIMENSIONS AND TOLERANCES IN ACCORDANCE WITH ASME Y14.5M-1994. SEE NOTES FOR TOLERANCES.					
DESCRIPTION: BLADEUPS SITEPLAN DRW (PRECONFIG-WRIGHTLINE) W/4-POS BLADEBAR (TOP ENTRY)					
ORIGINATED: GOLDEN_D	17-JUL-2012	ECCO:ECO-117817	NAME:	REVISION:04	SIZE: A3
MODIFIED: R. SINGH	23-MAR-2017		P-110000115-004	STATE:RELEASE	NOT TO SCALE
CHECKED:		DOCUMENT TYPE:			SHEET: 8 OF 10
SAFETY:		AUTOCAD DRAWING			
APPROVED:					
EATON CORPORATION - CONFIDENTIAL AND PROPRIETARY NOTICE TO PERSONS RECEIVING THIS DOCUMENT AND/OR TECHNICAL INFORMATION THIS DOCUMENT, INCLUDING THE DRAWING AND INFORMATION CONTAINED THEREON, IS CONFIDENTIAL AND IS THE EXCLUSIVE PROPERTY OF EATON CORPORATION, AND IS MERELY ON LOAN AND SUBJECT TO RECALL BY EATON AT ANY TIME. BY TAKING POSSESSION OF THIS DOCUMENT, THE RECIPIENT ACKNOWLEDGES AND AGREES THAT THIS DOCUMENT CANNOT BE USED IN ANY MANNER ADVERSE TO THE INTERESTS OF EATON AND THAT NO PORTION OF THIS DOCUMENT MAY BE COPIED OR OTHERWISE REPRODUCED WITHOUT THE PRIOR WRITTEN CONSENT OF EATON. IN THE CASE OF CONFLICTING CONTRACTUAL PROVISIONS, THIS NOTICE SHALL GOVERN THE STATUS OF THIS DOCUMENT. © 2011 Eaton Corporation - All Rights Reserved.					

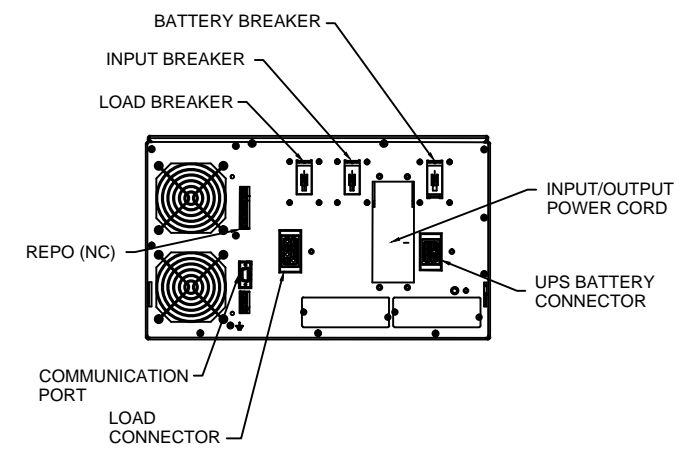
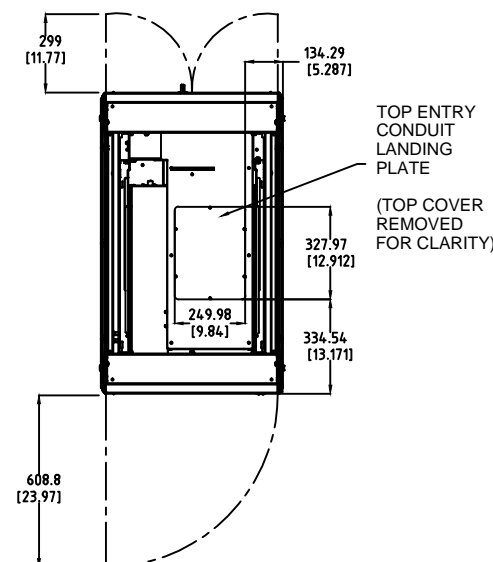

- NOTES
- FOR OPTIONAL MOUNTING BRACKETS USE SHIPPING BRACKETS.
 - CENTER OF GRAVITY AND WEIGHT: SEE TABLE
 - THE SYSTEM MUST BE INSTALLED ON A LEVEL FLOOR SURFACE SUITABLE FOR COMPUTER OR ELECTRONIC EQUIPMENT.
 - THE SYSTEM MUST BE INSTALLED IN A TEMPERATURE AND HUMIDITY CONTROLLED INDOOR AREA FREE OF CONDUCTIVE CONTAMINANTS.
 - AMBIENT TEMPERATURE RANGE 0-40°C [32-104°F]; RECOMMENDED OPERATING RANGE: 20-25°C [68-77°F]; MAXIMUM RELATIVE HUMIDITY: 95% NON-CONDENSING.
 - MINIMUM 900MM [36 IN] FRONT ACCESS AND 900MM [36 IN] REAR ACCESS NEEDED FOR SERVICING.
 - MINIMUM 400 MM [15.7 IN] CLEARANCE IN REAR, NOT INCLUDING CUSTOMER CONNECTION COVER, IS NEEDED FOR VENTILATION EXHAUST.
 - MINIMUM 575MM [22.6 IN] CLEARANCE IN FRONT IS NEEDED FOR COOLING AIR INTAKE AND DOOR SWING.
 - THE UPS CABINET CAN BE INSTALLED IN LINE-UP-AND-MATCH OR STANDALONE CONFIGURATIONS.
 - BOTTOM OR TOP CABLE ENTRY THROUGH REMOVABLE CONDUIT LANDING PLATE. PLATE SHALL BE CUSTOM MODIFIED TO SUIT CONDUIT SIZES.
 - ALL WIRING IS TO BE IN ACCORDANCE WITH NATIONAL AND LOCAL ELECTRIC CODES.
 - AC INPUT TO UPS RECTIFIER (0.98 MIN PF): 3 PHASES, 1 NEUTRAL, 1 GROUND.
AC OUTPUT TO LOAD: 3 PHASES, 1 NEUTRAL, 1 GROUND.
DC INPUT TO UPS (EXTERNAL BATTERY ONLY): 1 POSITIVE, 1 NEGATIVE, 1 GROUND.
 - SPECIFICATIONS ARE SUBJECT TO CHANGE.

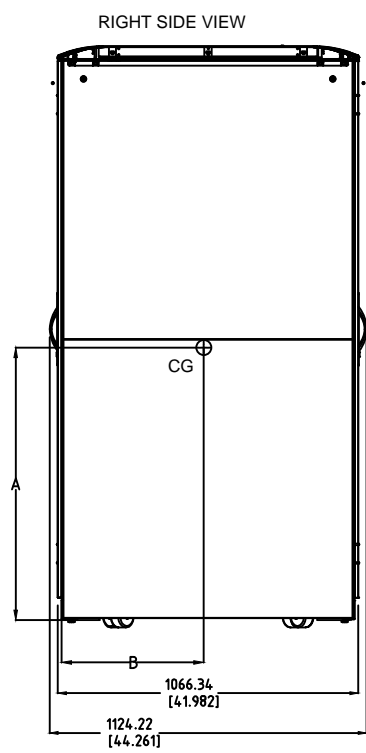
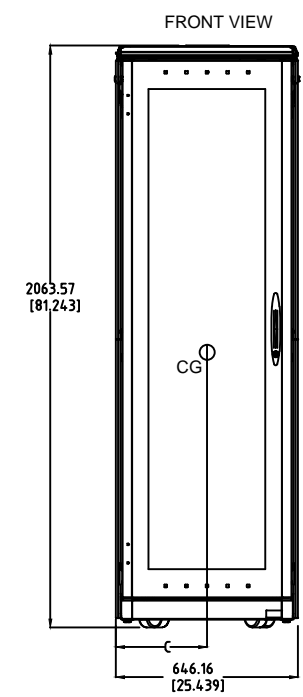

1 HIGH WITH MBM

TOP ENTRY

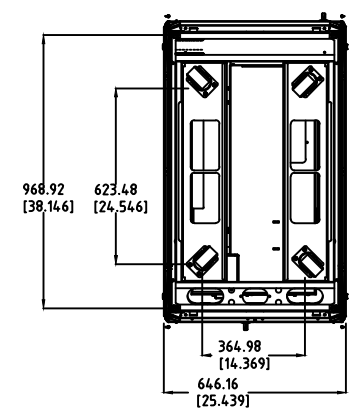
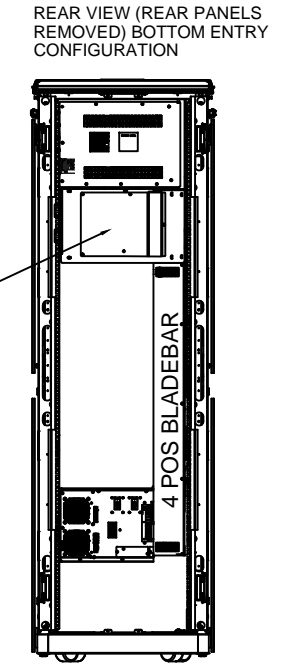
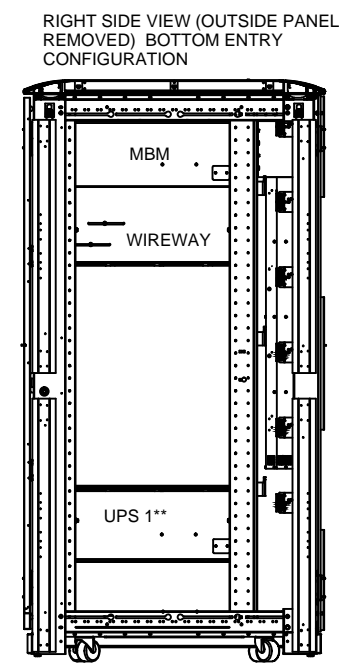

**NOTE: UPS POSITIONS SHOWN ARE REQUIRED FOR ALL CONFIGURATIONS

WEIGHT AND CENTER OF GRAVITY		TOP ENTRY CONFIGURATION		
CONFIGURATION	WEIGHT *	A	B	C
RACK W/ 1 UPS WITH MBM	343.4 kg [757 lbs]	917 [36.10]	384 [15.12]	242 [9.53]

METRIC	THIRD ANGLE PROJECTION	EATON CORPORATION		EATON	
DIMENSIONS ARE IN MILLIMETERS AFTER PLATING, DIMENSIONS AND TOLERANCES IN ACCORDANCE WITH ASME Y14.5M-1994. SEE NOTES FOR TOLERANCES.					
DESCRIPTION: BLADEUPS SITEPLAN DRW (PRECONFIG-WRIGHTLINE) W/4-POS BLADEBAR (TOP ENTRY)					
ORIGINATED: GOLDEN_D	17-JUL-2012	ECCO:ECO-117817	NAME:	REVISION:04	SIZE: A3
MODIFIED: R. SINGH	23-MAR-2017			STATE:RELEASE	NOT TO SCALE
CHECKED:		DOCUMENT TYPE:	P-110000115-004		SHEET: 9 OF 10
SAFETY:		AUTOCAD DRAWING			
APPROVED:		EATON CORPORATION - CONFIDENTIAL AND PROPRIETARY NOTICE TO PERSONS RECEIVING THIS DOCUMENT AND/OR TECHNICAL INFORMATION			
THIS DOCUMENT, INCLUDING THE DRAWING AND INFORMATION CONTAINED THEREON, IS CONFIDENTIAL AND IS THE EXCLUSIVE PROPERTY OF EATON CORPORATION, AND IS MERELY ON LOAN AND SUBJECT TO RECALL BY EATON AT ANY TIME. BY TAKING POSSESSION OF THIS DOCUMENT, THE RECIPIENT ACKNOWLEDGES AND AGREES THAT THIS DOCUMENT CANNOT BE USED IN ANY MANNER ADVERSE TO THE INTERESTS OF EATON AND THAT NO PORTION OF THIS DOCUMENT MAY BE COPIED OR OTHERWISE REPRODUCED WITHOUT THE PRIOR WRITTEN CONSENT OF EATON. IN THE CASE OF CONFLICTING CONTRACTUAL PROVISIONS, THIS NOTICE SHALL GOVERN THE STATUS OF THIS DOCUMENT. © 2011 Eaton Corporation - All Rights Reserved.					

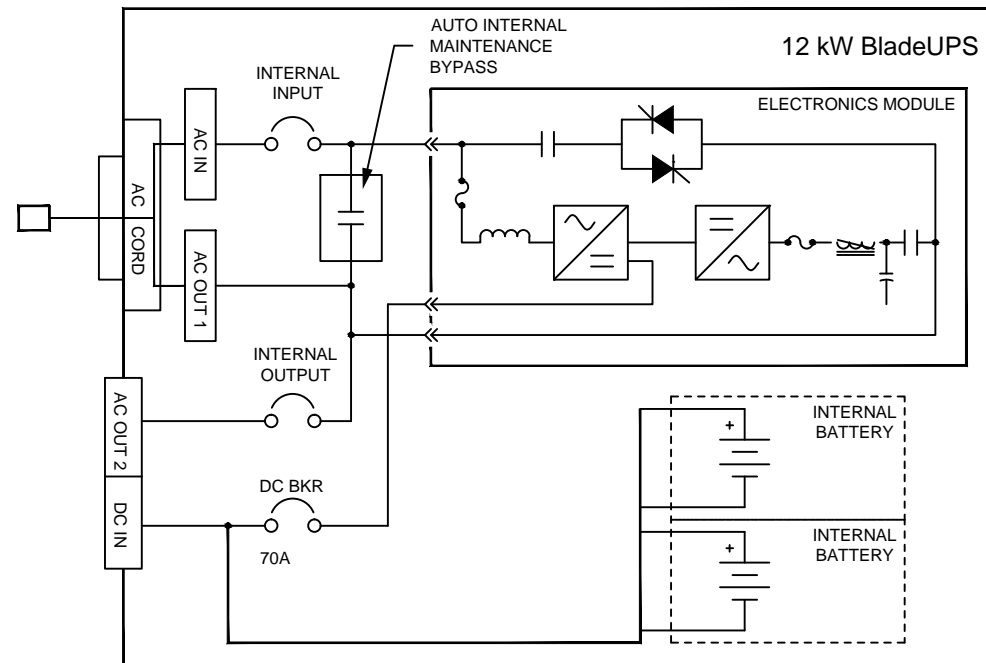

TABLE 2 - CUSTOMER WIRING

WIRES	ACCEPTED WIRE RANGE	TORQUE RATING	RECOMMENDED WIRE SIZE FOR COPPER STRANDED WIRE
		N*M [LB.*IN.]	
INPUT PHASE WIRES	6 AWG TO 350 kcmil	31.1 [275]	NOTE: WIRE GAUGE DEPENDS ON OVERCURRENT PROTECTION RATING REQUIRED (SEE TABLE 1). REFERENCE THE NEC, NFPA 70 FOR WIRE SIZING.
INPUT NEUTRAL WIRE	6 AWG TO 350 kcmil		
OUTPUT PHASE WIRES	6 AWG TO 350 kcmil		
OUTPUT NEUTRAL WIRE	6 AWG TO 350 kcmil		
GROUND WIRES	4 AWG TO 350 kcmil		

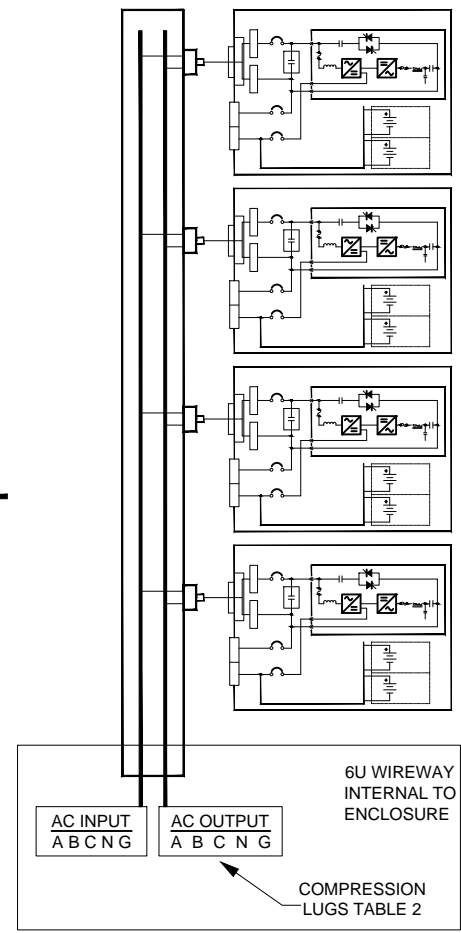
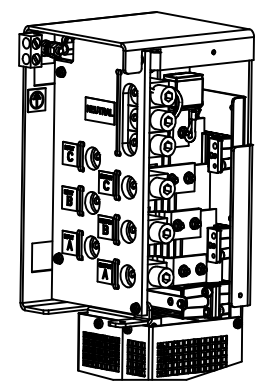
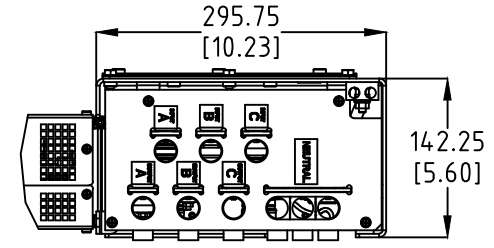

TABLE 1 - PRODUCT SPECIFICATIONS

NUMBER OF UPS MODULES	UPS RATING		AC INPUT VOLTAGE	AC OUTPUT VOLTAGE	INTERNAL BREAKER RATINGS		RATED AC INPUT CURRENT	RATED AC OUTPUT CURRENT	INPUT OVERCURRENT PROTECTION NEEDED	MAX HEAT DISSIPATION AT 100% LOAD
	KVA	KW			NAMEPLATE	NAMEPLATE				
	VAC	VAC			AMP	AMP				
1	12	12	208/120	208/120	50A	50A	36	33.3	50	1.2 [4094]
	24	24					72	66.6	100	2.4 [8088]
	36	36					108	99.9	150	3.6 [12282]
	48	48					144	133.2	200	4.8 [16376]
2	12	12	400/230	400/230	30A	25A	20	17.3	30	1.2 [4094]
	24	24					40	34.6	63	2.4 [8088]
	36	36					60	51.9	75	3.6 [12282]
	48	48					80	69.2	100	4.8 [16376]

POWER WIRING



INPUT-OUTPUT POWER WIRING

METRIC		EATON CORPORATION			
DIMENSIONS ARE IN MILLIMETERS AFTER PLATING, DIMENSIONS AND TOLERANCES IN ACCORDANCE WITH ASME Y14.5M-1994. SEE NOTES FOR TOLERANCES.					
DESCRIPTION: BLADEUPS SITEPLAN DRW (PRECONFIG-WRIGHTLINE) W/4-POS BLADEBAR (TOP ENTRY)					
ORIGINATED: GOLDEN_D	17-JUL-2012	ECO:ECO-117817	NAME:	REVISION:04	SIZE: A3
MODIFIED: R. SINGH	23-MAR-2017		DOCUMENT TYPE: P-110000115-004	STATE:RELEASE	NOT TO SCALE
CHECKED:					SHEET: 10 OF 10
SAFETY:					
APPROVED:					
EATON CORPORATION - CONFIDENTIAL AND PROPRIETARY NOTICE TO PERSONS RECEIVING THIS DOCUMENT AND/OR TECHNICAL INFORMATION THIS DOCUMENT, INCLUDING THE DRAWING AND INFORMATION CONTAINED THEREON, IS CONFIDENTIAL AND IS THE EXCLUSIVE PROPERTY OF EATON CORPORATION, AND IS MERELY ON LOAN AND SUBJECT TO RECALL BY EATON AT ANY TIME. BY TAKING POSSESSION OF THIS DOCUMENT, THE RECIPIENT ACKNOWLEDGES AND AGREES THAT THIS DOCUMENT CANNOT BE USED IN ANY MANNER ADVERSE TO THE INTERESTS OF EATON AND THAT NO PORTION OF THIS DOCUMENT MAY BE COPIED OR OTHERWISE REPRODUCED WITHOUT THE PRIOR WRITTEN CONSENT OF EATON. IN THE CASE OF CONFLICTING CONTRACTUAL PROVISIONS, THIS NOTICE SHALL GOVERN THE STATUS OF THIS DOCUMENT. © 2011 Eaton Corporation - All Rights Reserved.					