

Eaton® BladeUPS® Bar

Installation Guide



Powering Business Worldwide

Eaton® BladeUPS® Bar

Installation Guide



Powering Business Worldwide

Special Symbols

The following are examples of symbols used on the UPS or accessories to alert you to important information:



RISK OF ELECTRIC SHOCK - Observe the warning associated with the risk of electric shock symbol.



CAUTION: REFER TO OPERATOR'S MANUAL - Refer to your operator's manual for additional information, such as important operating and maintenance instructions.



This symbol indicates that you should not discard the UPS or the UPS batteries in the trash. This product contains sealed, lead-acid batteries and must be disposed of properly. For more information, contact your local recycling/reuse or hazardous waste center.



This symbol indicates that you should not discard waste electrical or electronic equipment (WEEE) in the trash. For proper disposal, contact your local recycling/reuse or hazardous waste center.

Eaton, Powerware, and BladeUPS are registered trademarks of Eaton Corporation or its subsidiaries and affiliates. Pozidriv is a registered trademark of Phillips Screw Company. All other trademarks are properties of their respective companies.

©Copyright 2010-2019 Eaton Corporation, Raleigh, NC, USA. All rights reserved. No part of this document may be reproduced in any way without the express written approval of Eaton Corporation.

TABLE OF CONTENTS

1	INTRODUCTION	1
	Safety Warnings	1
2	INSTALLATION	5
	Inspecting the Equipment	5
	Setup	5
	Tools Required	5
	Checking the Package Contents	5
	BladeUPS Bar Installation	6
	BladeUPS Bar Installation (Bottom Entry Wireway)	6
	BladeUPS Bar Installation (Top Entry Wireway)	13
3	SPECIFICATIONS	23
4	SERVICE AND SUPPORT	25
	Installation support (toll free)	25
5	WARRANTY	27
	Limited Warranty (Global)	27

This page intentionally left blank.

Chapter 1 Introduction

Paralleled Eaton BladeUPS® uninterruptible power systems (UPSs) use the Eaton BladeUPS Bar to provide the required input and output connections. The BladeUPS Bar installs in an industry standard rack and is available in three models:

- **BladeUPS Bar 3-High:** Connects up to three of the BladeUPS modules.
- **BladeUPS Bar 4-High:** Connects up to four of the BladeUPS modules.
- **BladeUPS Bar 6-High:** Connects up to six of the BladeUPS modules.

Figure 1 shows the installed BladeUPS Bar in a bottom entry and top entry wireway configuration. The wireway fits into the bottom or top 6U of standard rack space

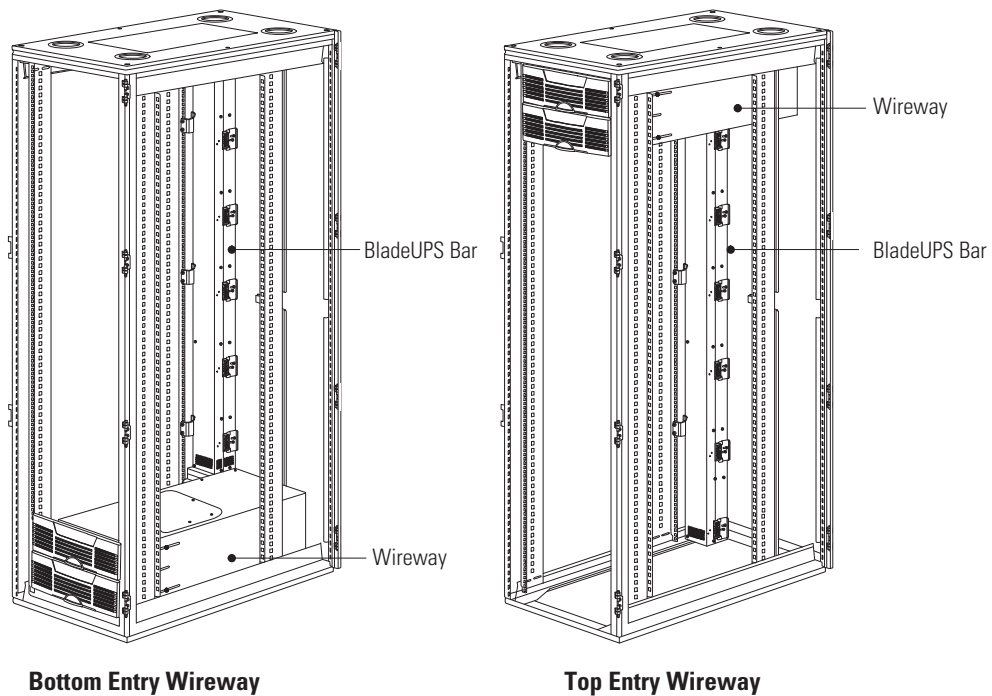

Figure 1. BladeUPS Bar Installed in Rack (BladeUPS Bar 6-High Shown)

Safety Warnings

IMPORTANT SAFETY INSTRUCTIONS SAVE THESE INSTRUCTIONS

This manual contains important instructions that should be followed during installation and maintenance of the UPS and batteries. Read all instructions before operating the equipment and save this manual for future reference.

VIGTIGE SIKKERHEDSANVISNINGER GEM DISSE ANVISNINGER

Denne manual indeholder vigtige instruktioner, som skal følges under installation og vedligeholdelse af UPS'en og batterierne. Læs venligst alle instruktioner inden betjening af udstyret og gem denne manual mhp. fremtidige opslag.

BELANGRIJKE VEILIGHEIDSINSTRUCTIES BEWAAR DEZE INSTRUCTIES

Deze handleiding bevat belangrijke instructies die u dient te volgen tijdens de installatie en het onderhoud van de UPS en de accu's. Lees alle instructies voordat u de apparatuur in bedrijf neemt en bewaar deze handleiding als naslagwerk.

TÄRKEITÄ TURVAOHJEITA - SUOMI SÄILYTÄ NÄMÄ OHJEET

Tämä käyttöohje sisältää tärkeitä ohjeita, joita on noudatettava UPS-virtalähteen ja akkujen asennuksen ja huollon yhteydessä. Lue kaikki ohjeet ennen laitteiston käyttöä ja säilytä ohje myöhempää tarvetta varten.

CONSIGNES DE SÉCURITÉ IMPORTANTES CONSERVER CES INSTRUCTIONS

Ce manuel contient des instructions importantes que vous êtes invité à suivre lors de toute procédure d'installation et de fonctionnement de la BladeUPS Bar. Veuillez consulter entièrement ces instructions avant de faire fonctionner l'équipement et conserver ce manuel afin de pouvoir vous y reporter ultérieurement.

WICHTIGE SICHERHEITSANWEISUNGEN AUFBEWAHREN

Dieses Handbuch enthält wichtige Hinweise, welche Sie bei der Installation und Wartung des BladeUPS Bar beachten sollten. Bitte lesen Sie alle Anweisungen des Handbuches bevor sie mit dem Gerät arbeiten. Bewahren Sie das Handbuch zum Nachlesen auf.

IMPORTANTI ISTRUZIONI DI SICUREZZA CONSERVARE QUESTE ISTRUZIONI

Il presente manuale contiene importanti istruzioni da seguire durante l'installazione e il funzionamento di BladeUPS Bar. Leggere integralmente le istruzioni prima di utilizzare l'apparecchiatura e conservare il presente manuale per futuro riferimento.

VIKTIGE SIKKERHETSINSTRUKSJONER GJEM DISSE INSTRUKSJONENE

Denne håndboken inneholder viktige instruksjoner som du bør overholde ved montering og vedlikehold av UPS-enheten og batteriene. Les alle instruksjoner før utstyret tas i bruk, og gjem håndboken til fremtidig referanse.

INSTRUÇÕES DE SEGURANÇA IMPORTANTES GUARDE ESTAS INSTRUÇÕES

Este manual contém instruções importantes que devem ser seguidas durante a instalação e operação da BladeUPS Bar. Leia todas as instruções antes de operar o equipamento e guarde este manual para consultá-lo futuramente.

ВАЖНЫЕ УКАЗАНИЯ ПО МЕРАМ БЕЗОПАСНОСТИ СОХРАНИТЕ ЭТИ УКАЗАНИЯ

В данном руководстве содержатся важные инструкции по установке и обслуживанию внешнего батарейного модуля или устройства распределения электропитания. Перед работой с оборудованием прочтите все инструкции. Сохраните данное руководство для дальнейшего использования.

INSTRUCCIONES DE SEGURIDAD IMPORTANTES GUARDE ESTAS INSTRUCCIONES

Este manual contiene instrucciones importantes que debe seguir durante la instalación y el funcionamiento del BladeUPS Bar. Por favor, lea todas las instrucciones antes de poner en funcionamiento el equipo y guarde este manual para referencia en el futuro.

VIKTIGA SÄKERHETSFÖRESKRIFTER SPARA DESSA FÖRESKRIFTER

Den här anvisningen innehåller viktiga instruktioner som du ska följa under installation och användning av BladeUPS Bar. Läs alla instruktioner innan du använder utrustningen och spara den här anvisningen för framtida referens.

This page intentionally left blank.

Chapter 2 Installation

This section explains:

- Equipment inspection
- BladeUPS Bar setup and installation

Inspecting the Equipment

If any equipment has been damaged during shipment, keep the shipping cartons and packing materials for the carrier or place of purchase, and file a claim for shipping damage. If you discover damage after acceptance, file a claim for concealed damage.

To file a claim for shipping damage or concealed damage: 1) File with the carrier within 15 days of receipt of the equipment; 2) Send a copy of the damage claim within 15 days to your service representative.

Setup

The BladeUPS Bar comes with all hardware required for installation in a standard EIA or JIS rack with square and round mounting holes.

Tools Required

To assemble the components, you may need the following tools:

- Torque wrench with the following attachments:
 - Hex socket size 10 mm for M6 hex bolt
 - Hex socket size 8 mm for M5 hex bolt
- Torque driver with a Pozidriv® #2 for Pozidriv M4 screw
- Large screwdriver or crowbar for lifting the bar in place
- Pliers for installing cage nuts

Checking the Package Contents

Verify that the following items are included in the package:

- One of the following BladeUPS Bars:

BladeUPS Bar 3-High. A three-socket bar with (1) attached terminal block assembly, (1) attached terminal block assembly bracket, and (2) attached mounting brackets

BladeUPS Bar 4-High. A four-socket bar with (1) attached terminal block assembly, (1) attached terminal block assembly bracket, and (2) attached mounting brackets

BladeUPS Bar 6-High. A six-socket bar with (1) attached terminal block assembly, (1) attached terminal block assembly bracket, and (3) attached mounting brackets

- Wireway main housing with (2) attached side brackets, (1) attached terminal block housing, and (1) attached wireway access cover
- Front cover mounting panel (2) front covers
- Ferrite assembly with 38 cm (15") tie wrap
- This user's guide
- Packaged hardware items:
 - **BladeUPS Bar 3-High.** 12) M6x12 hex bolts, plus (1) extra
 - **BladeUPS Bar 4-High.** (12) M6 x 12 hex bolts, plus (1) extra

- **BladeUPS Bar 6-High.** (14) M6 x 12 hex bolts, plus (1) extra
- (4) M5 x 16 hex bolts
- (6) M6 x 12 pan-head screws, plus (1) extra
- (3) M4 x 8 pan-head screws
- (6) M6 split lock washers, plus (1) extra
- (4) M5 cage nuts
- (3) M6 hex nuts, plus (1) extra

BladeUPS Bar Installation

Follow the appropriate procedure for the BladeUPS Bar wireway location:

- Follow the procedure Chapter 2, “BladeUPS Bar Installation (Bottom Entry Wireway)” on page 6 if you are installing the bar with the wireway at the bottom of the rack.
- Follow the procedure Chapter 2, “BladeUPS Bar Installation (Top Entry Wireway)” on page 13 if you are installing the bar with the wireway at the top of the rack.

BladeUPS Bar Installation (Bottom Entry Wireway)

To install the BladeUPS Bar in a bottom entry rack:

1. Remove the access cover and terminal block housing from the wireway housing (see Figure 2). Retain the wireway terminal block housing, wireway access cover, and screws. Leave the two side brackets installed on the wireway housing (see side bracket locations in Figure 3).
2. Verify that the side brackets are in the most closed position and that the adjustment screws are tightened to prevent the side brackets from moving

CAUTION

If the side brackets are loose, they can move during wireway placement and cause injury.

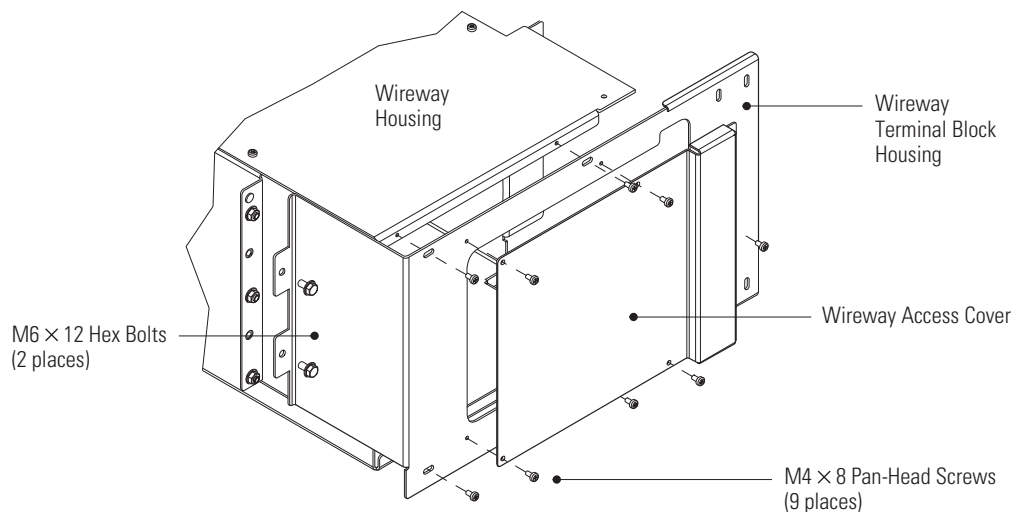

Figure 2. Wireway Disassembly

3. Place the wireway housing into the bottom of the rack so that the adjustable side brackets are nearest the front of the rack (see Figure 3).

4. Install an M6 hex nut onto each of the three wireway studs to secure the wireway to the rear of the rack. Install the first stud in the fourth hole location from the bottom. Do not tighten the nuts. Figure 4 shows the nuts installed.
5. Loosen the three adjustment screws on each side of the wireway housing and adjust the side brackets for the depth of the rack. Do not retighten the screws.
6. Install six M6 x 12 pan-head screws and M6 split lock washers to secure the two wireway side brackets to the front of the rack. Install the first screws in the fifth hole location from the bottom. Torque the screws to 5.1 ± 0.8 Nm (45 ± 7 lb in).
7. Tighten the three M6 hex nuts installed in Step 4. Torque the nuts to 5.1 ± 0.8 Nm (45 ± 7 lb in).
8. Retighten the six side bracket adjustment screws loosened in Step 5. Torque to 3.4 Nm (30 lb in).

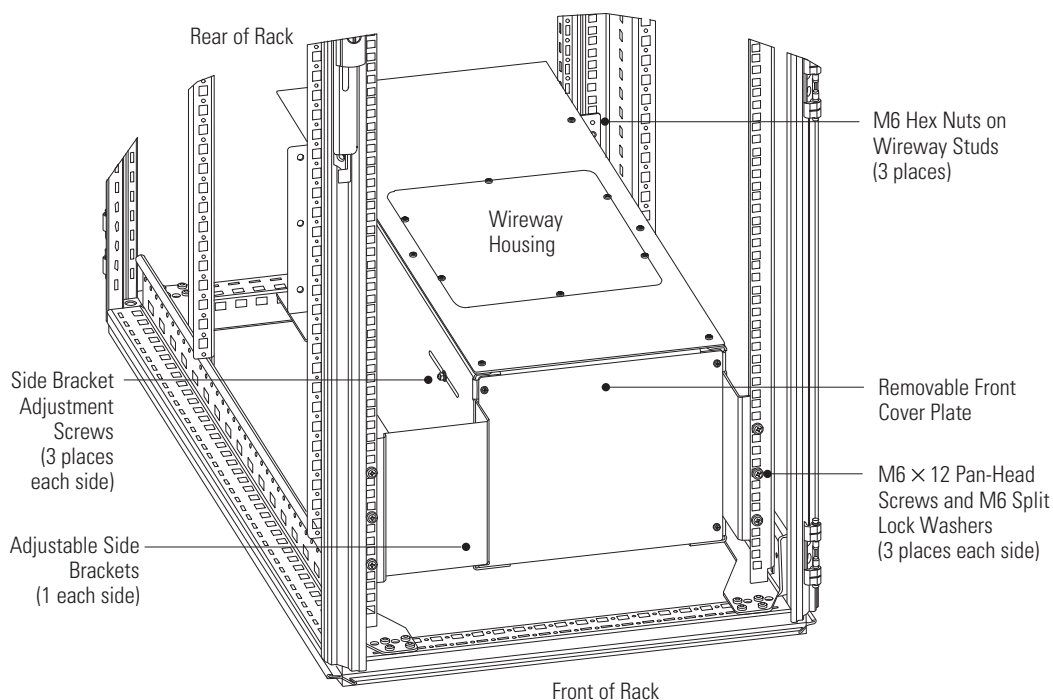

Figure 3. Wireway Installation

9. Place the ferrite assembly on the floor of the wireway and secure with the supplied tie wrap. Loop the tie wrap through both attachment sites on the wireway floor and through the ferrite assembly. See Figure 4.
10. Note the orientation of the terminal block assembly bracket installed on the bar for later re-installation (see Figure 5). Remove and retain the terminal block assembly bracket and hardware.
11. Place the bar in the rack as shown in Figure 4.



NOTE

The bar can rest on the floor of the rack until secured in place. After complete installation, the bar will be secured to the rack and wireway as shown in Figure 4.

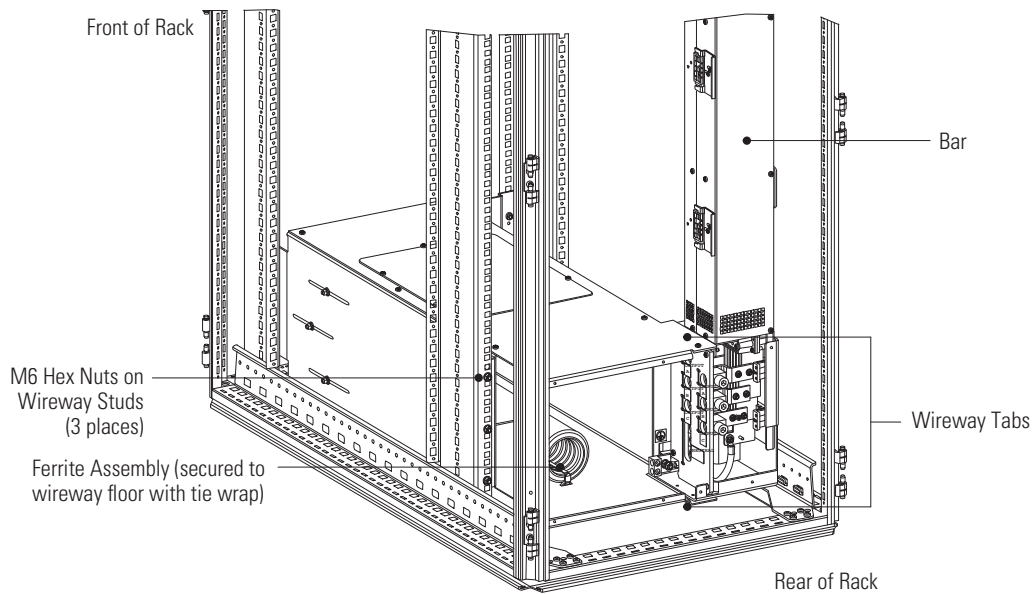

Figure 4. Ferrite and Bar Placement



NOTE Verify that the bar is secure as shown in Figure 4. The sheet metal at the top and bottom of the of the terminal block assembly should fit between the wireway tabs.

12. Secure the bar to the wireway with three M6 x 12 hex bolts. Install the bolts from the **front** of the rack. See Figure 5. Torque the bolts to 5.1 ± 0.8 Nm (45 ± 7 lb in).
13. Reinstall the terminal block assembly bracket removed in Step 10. Install the bolts from the **front** of the rack. See Figure 5. Torque the bolts to 5.1 ± 0.8 Nm (45 ± 7 lb in).

NOTE Do not change the original orientation of the terminal block assembly bracket. Verify that the threaded holes mount to the rack, not to the bar.

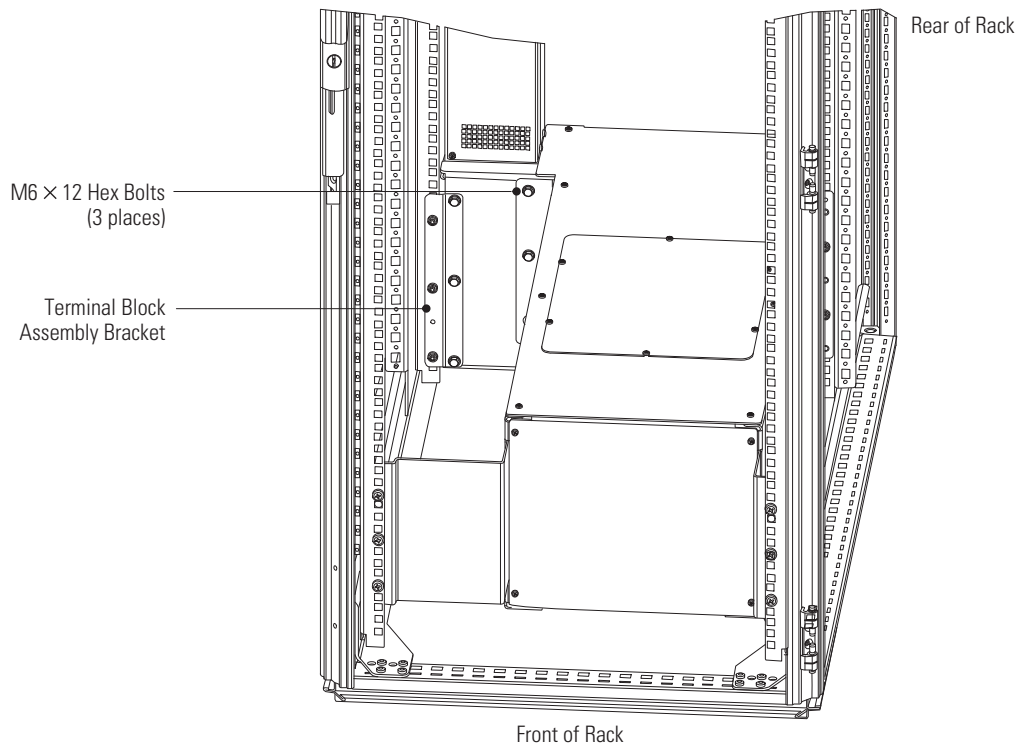

Figure 5. Terminal Block Assembly Installation

14. Secure the terminal block assembly bracket to the rack with three M6 x 12 hex bolts. Install the bolts from the **rear** of the rack.

Use a large screwdriver or crowbar to lift the bar in place to align the holes in the terminal block assembly bracket with the holes in the rack.

Install the lowest bolt in position 2, then use positions 8 and 14. Verify that the terminal block assembly bracket stud aligns completely with the rack hole between the lower and middle bolts (position 5). See Figure 6. Torque the bolts to 5.1 ± 0.8 Nm (45 ± 7 lb in).

15. **BladeUPS Bar 3-High.** Install two M6 x 12 hex bolts in each of the bar's two mounting brackets, securing the length of the bar to the rack. See Figure 6. Torque the bolts to 5.1 ± 0.8 Nm (45 ± 7 lb in).
16. **BladeUPS Bar 4-High.** Install two M6 x 12 hex bolts in each of the bar's two mounting brackets, securing the length of the bar to the rack. See Figure 6. Torque the bolts to 5.1 ± 0.8 Nm (45 ± 7 lb in).
17. **BladeUPS Bar 6-High.** Install two M6 x 12 hex bolts in each of the bar's three mounting brackets, securing the length of the bar to the rack. See Figure 6. Torque the bolts to 5.1 ± 0.8 Nm (45 ± 7 lb in).
18. Install an M4 x 8 pan-head screw to secure the wireway top panel to the bar. See Figure 6.

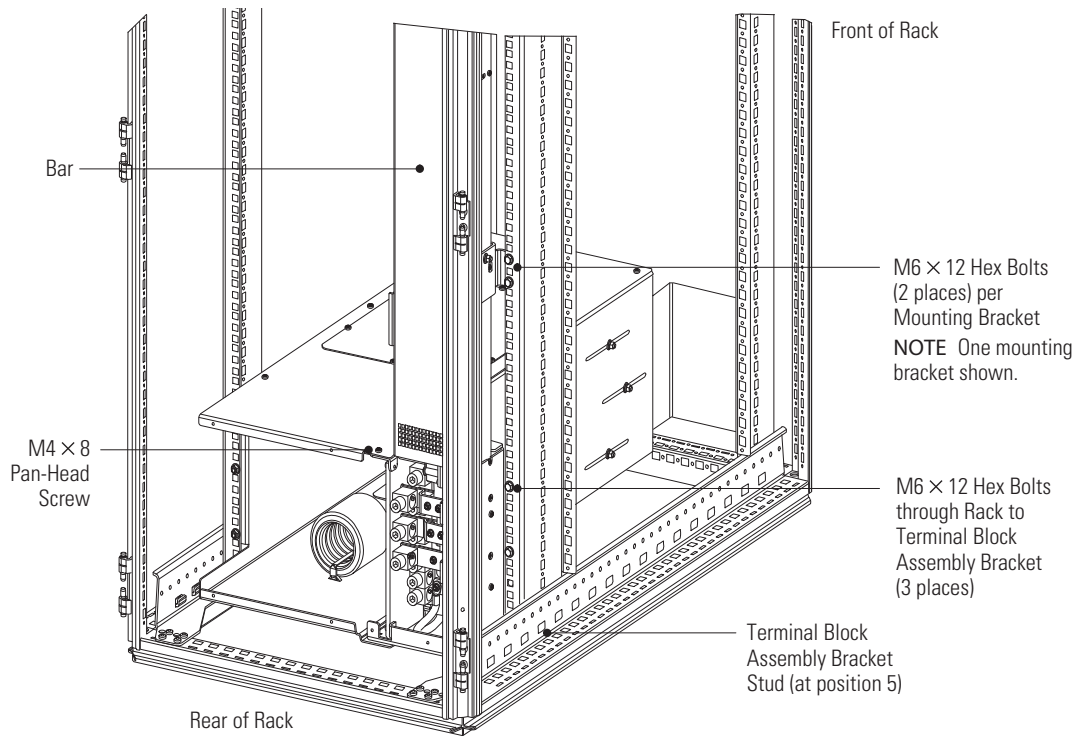

Figure 6. Bar Brackets Installation

NOTE Loosening the mounting brackets slightly may allow easier alignment to the vertical rail of the rack. Retighten the mounting brackets when alignment is complete.

19. Using two M6 x 12 hex bolts, secure the left side of the wireway terminal block housing to the rack. See Figure 7. Torque the bolts to 5.1 ± 0.8 Nm (45 ± 7 lb in).
20. Using six M4 x 8 pan-head screws, secure the wireway terminal block housing to the wireway and to the bar. See Figure 7. Torque the screws to 1.7 ± 0.2 Nm (15 ± 2 lb in).

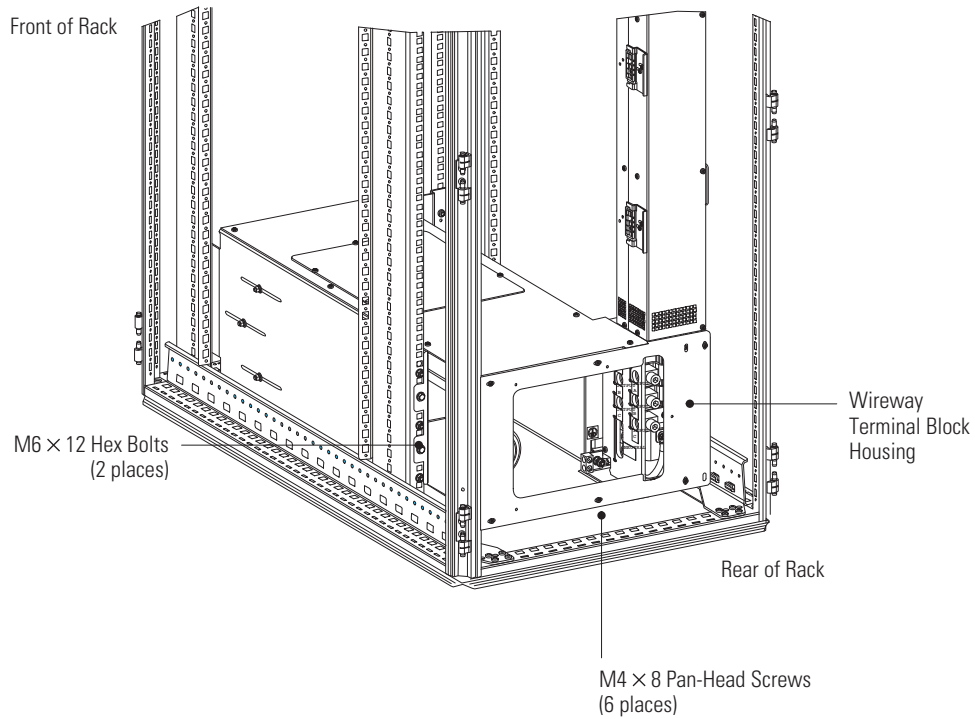

Figure 7. Wireway Terminal Block Housing Installation

21. Using five M4 x 8 pan-head screws, install the wireway access cover. See Figure 8. Torque the screws to $1.7 \pm 0.2 \text{ Nm}$ ($15 \pm 2 \text{ lb in}$).

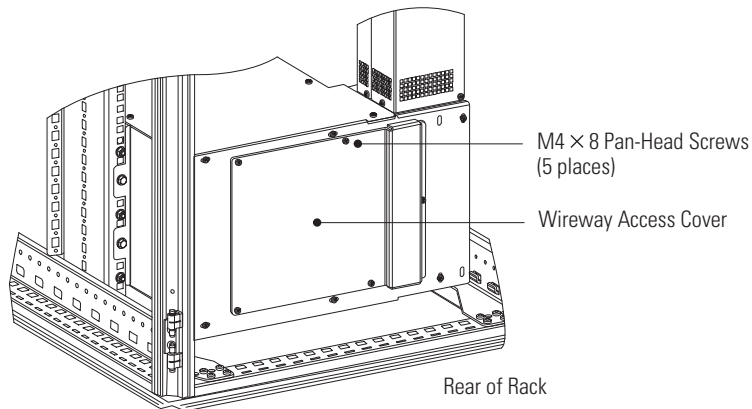

Figure 8. Wireway Access Cover Installation

22. Verify that the six information labels are attached to the wireway as shown in Figure 9.

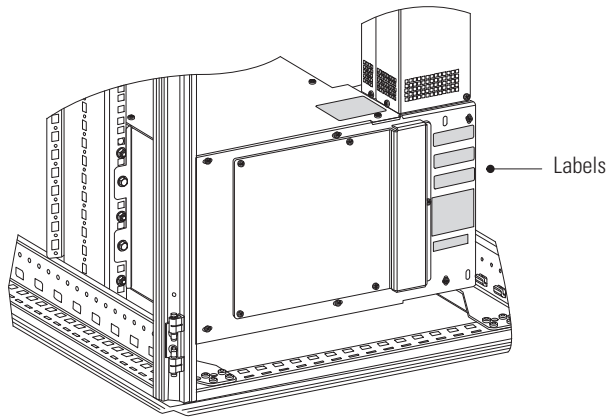

Figure 9. Wireway Labels

23. Using four M5 x 16 hex bolts and four M5 cage nuts, secure the front cover mounting panel to the front of the rack. Ensure that the bent edge of the panel is at the top. See Figure 10.

Install the lower bolts and cage nuts into the second holes from the bottom of the rack frame. Torque the bolts to 5.1 ± 0.8 Nm (45 ± 7 lb in).

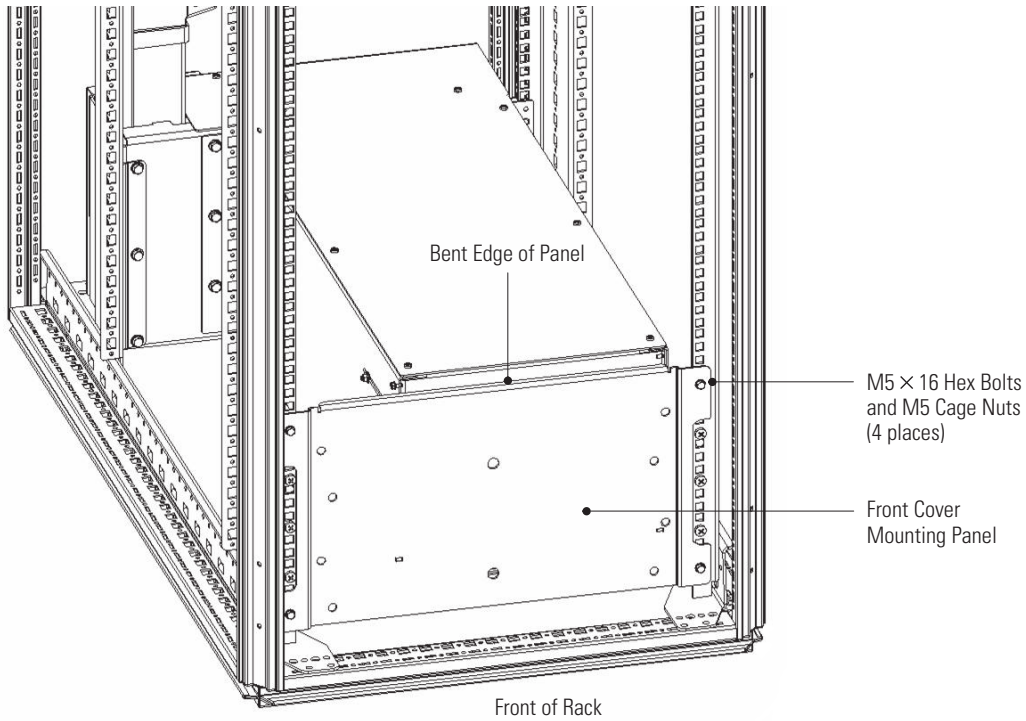

Figure 10. Front Cover Mounting Panel Installation

24. Snap the two front covers into place, as shown in Figure 11.

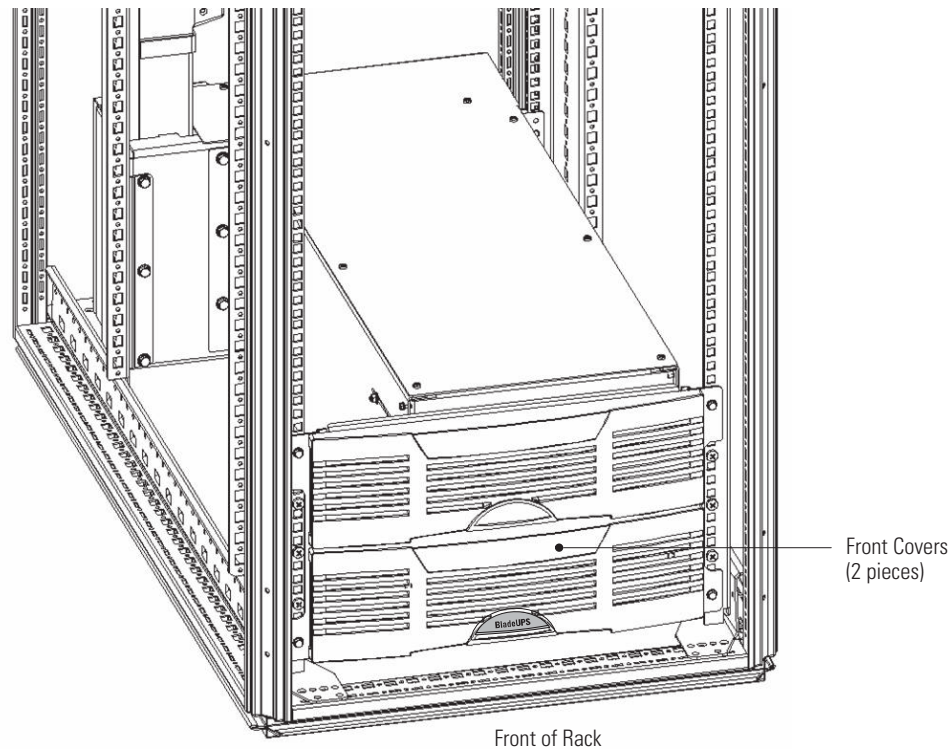

Figure 11. Front Cover Installation

25. Snap the two front covers into place, as shown in Figure 11.

BladeUPS Bar Installation (Top Entry Wireway)

To install the BladeUPS Bar in a top entry rack:

1. Remove the access cover and terminal block housing from the wireway housing (see Figure 12). Retain the wireway terminal block housing, wireway access cover, bolts, and screws. Leave the two side brackets installed on the wireway housing (see side bracket locations in Figure 13).
2. Verify that the side brackets are in the most closed position and that the adjustment screws are tightened to prevent the side brackets from moving.

⚠ CAUTION

If the side brackets are loose, they can move during wireway placement and cause injury.

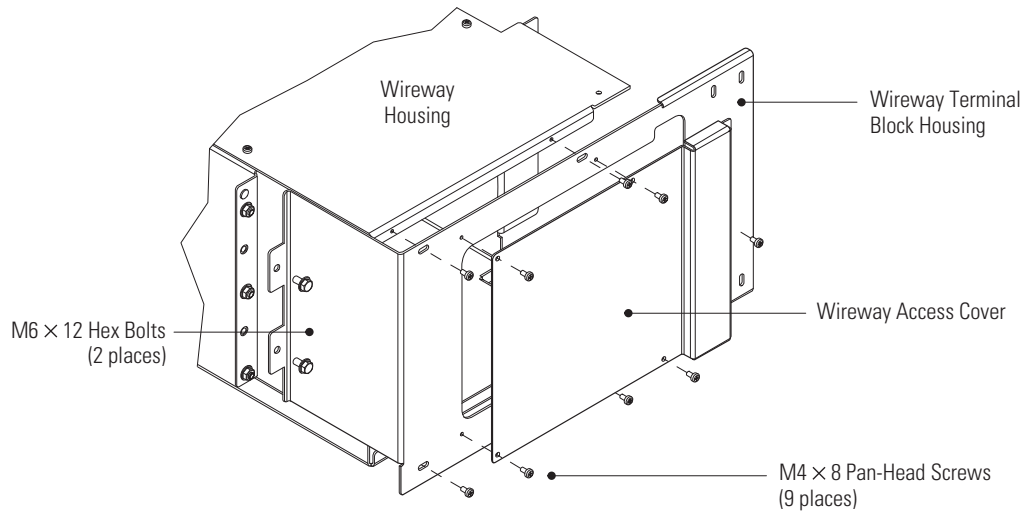

Figure 12. Wireway Disassembly

3. Place the wireway housing into the top of the rack so that the adjustable side brackets are nearest the front of the rack (see Figure 13).
4. Install an M6 hex nut onto each of the three wireway studs to secure the wireway to the rear of the rack. Install the first stud in the third hole location from the top. Do not tighten the nuts. Figure 14 shows the nuts installed.
5. Loosen the three adjustment screws on each side of the wireway housing and adjust the side brackets for the depth of the rack. Do not retighten the screws.
6. Install six M6 x 12 pan-head screws and M6 split lock washers to secure the two wireway side brackets to the front of the rack. Install the first screws in the sixth hole location from the top.
7. Torque the screws to 5.1 ± 0.8 Nm (45 ± 7 lb in).
8. Tighten the three M6 hex nuts installed in Step 4. Torque the nuts to 5.1 ± 0.8 Nm (45 ± 7 lb in).
9. Retighten the six side bracket adjustment screws loosened in Step 5. Torque to 3.4 Nm (30 lb in).

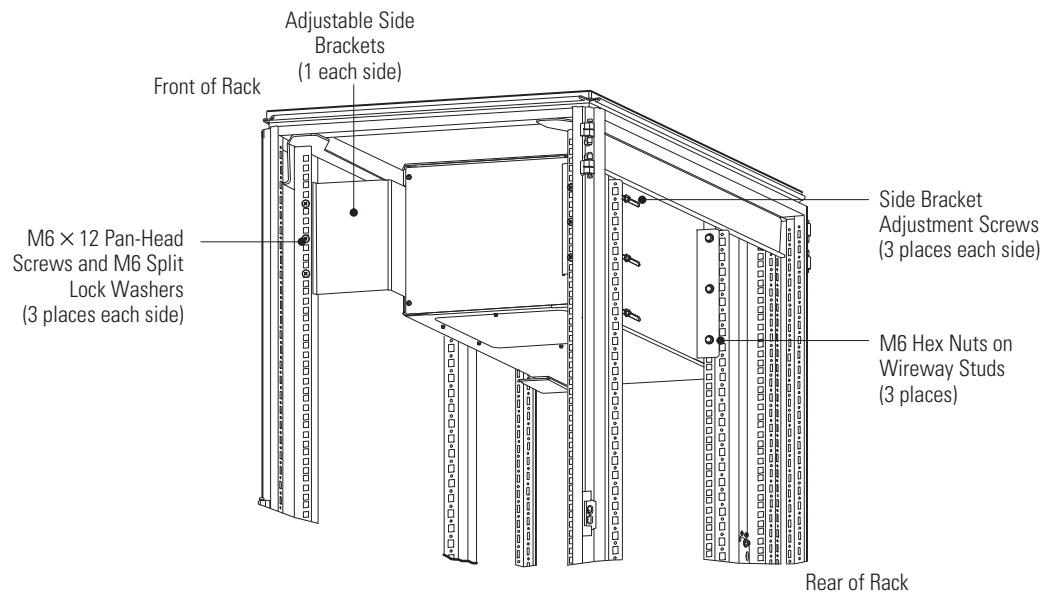

Figure 13. Wireway Installation

10. Place the ferrite assembly on the floor of the wireway and secure with the supplied tie wrap. Loop the tie wrap through both attachment sites on the wireway floor and through the ferrite assembly. See Figure 14.
11. Note the orientation of the terminal block assembly bracket installed on the bar for later re-installation (see Figure 15). Remove and retain the terminal block assembly bracket and hardware.
12. Place the bar in the rack as shown in Figure 14.

NOTE The bar can rest on a support until secured in place. After complete installation, the bar will be secured to the rack and wireway as shown in Figure 14.

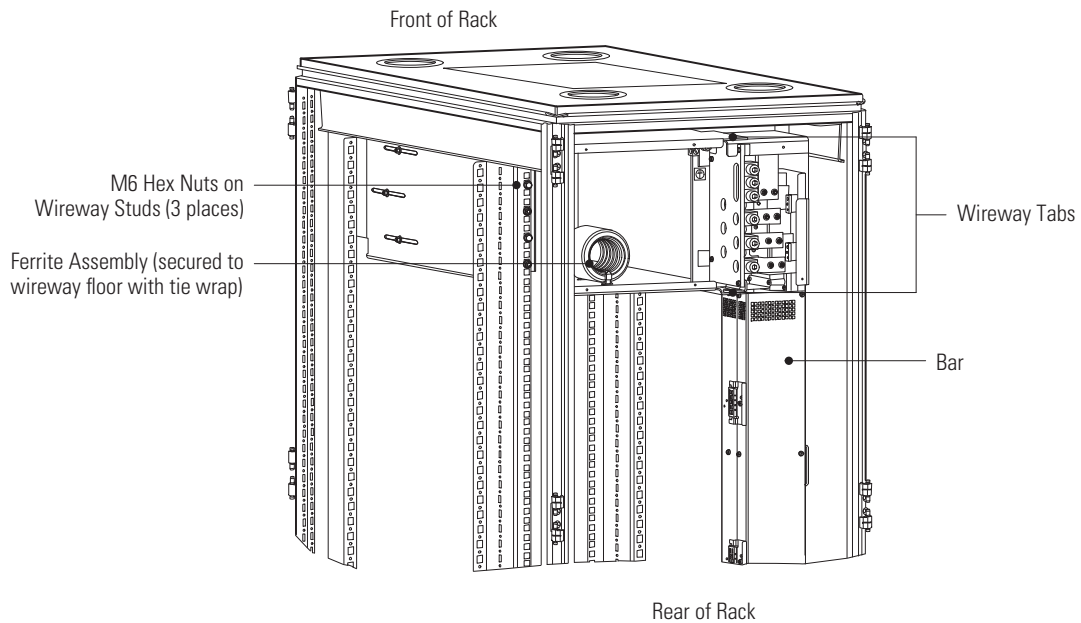

Figure 14. Ferrite and Bar Placement

NOTE Verify that the bar is secure as shown in Figure 14. The sheet metal at the top and bottom of the of the terminal block assembly should fit between the wireway tabs.

13. Secure the bar to the wireway with three M6 x 12 hex bolts. Install the bolts from the front of the rack. See Figure 15. Torque the bolts to 5.1 ± 0.8 Nm (45 ± 7 lb in).
14. Reinstall the terminal block assembly bracket removed in Step 10. Install the bolts from the front of the rack. See Figure 15. Torque the bolts to 5.1 ± 0.8 Nm (45 ± 7 lb in).

NOTE Do not change the original orientation of the terminal block assembly bracket. Verify that the threaded holes mount to the rack, not to the bar.

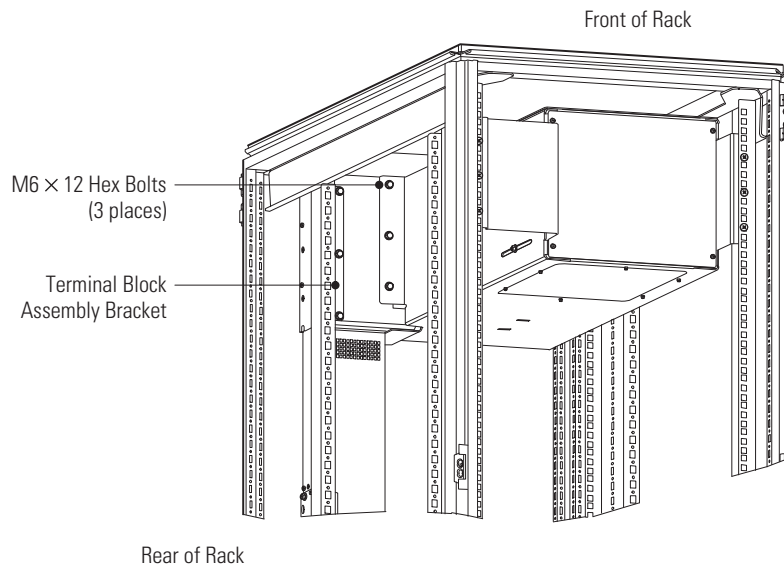

Figure 15. Terminal Block Assembly Installation

15. Secure the terminal block assembly bracket to the rack with three M6 x 12 hex bolts. Install the bolts from the **rear** of the rack.

Use a large screwdriver or crowbar to lift the bar in place to align the holes in the terminal block assembly bracket with the holes in the rack.

Install the highest bolt in position 5 from the top, then use positions 11 and 17. Verify that the terminal block assembly bracket stud aligns completely with the rack hole between the lower and middle bolts (position 14). See Figure 16. Torque the bolts to 5.1 ± 0.8 Nm (45 ± 7 lb in).

16. **BladeUPS Bar 3-High.** Install two M6 x 12 hex bolts in each of the bar's two mounting brackets, securing the length of the bar to the rack. See Figure 16. Torque the bolts to 5.1 ± 0.8 Nm (45 ± 7 lb in).
17. **BladeUPS Bar 4-High.** Install two M6 x 12 hex bolts in each of the bar's two mounting brackets, securing the length of the bar to the rack. See Figure 16. Torque the bolts to 5.1 ± 0.8 Nm (45 ± 7 lb in).
18. **BladeUPS Bar 6-High.** Install two M6 x 12 hex bolts in each of the bar's three mounting brackets, securing the length of the bar to the rack. See Figure 16. Torque the bolts to 5.1 ± 0.8 Nm (45 ± 7 lb in).
19. Install an M4 x 8 pan-head screw to secure the wireway top panel to the bar. See Figure 16.

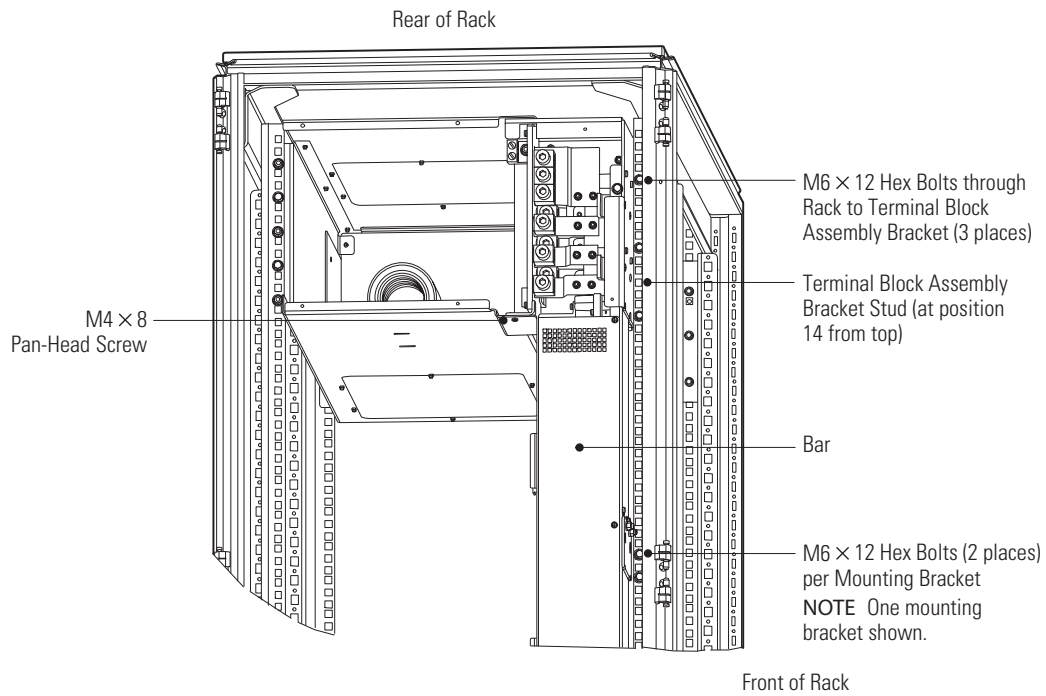

Figure 16. Bar Brackets Installation

NOTE Loosening the mounting brackets slightly may allow easier alignment to the vertical rail of the rack. Retighten the mounting brackets when alignment is complete.

20. Using two M6 x 12 hex bolts, secure the left side of the wireway terminal block housing to the rack. See Figure 17. Torque the bolts to 5.1 ± 0.8 Nm (45 ± 7 lb in).
21. Using six M4 x 8 pan-head screws, secure the wireway terminal block housing to the wireway and to the bar. See Figure 17. Torque the screws to 1.7 ± 0.2 Nm (15 ± 2 lb in).

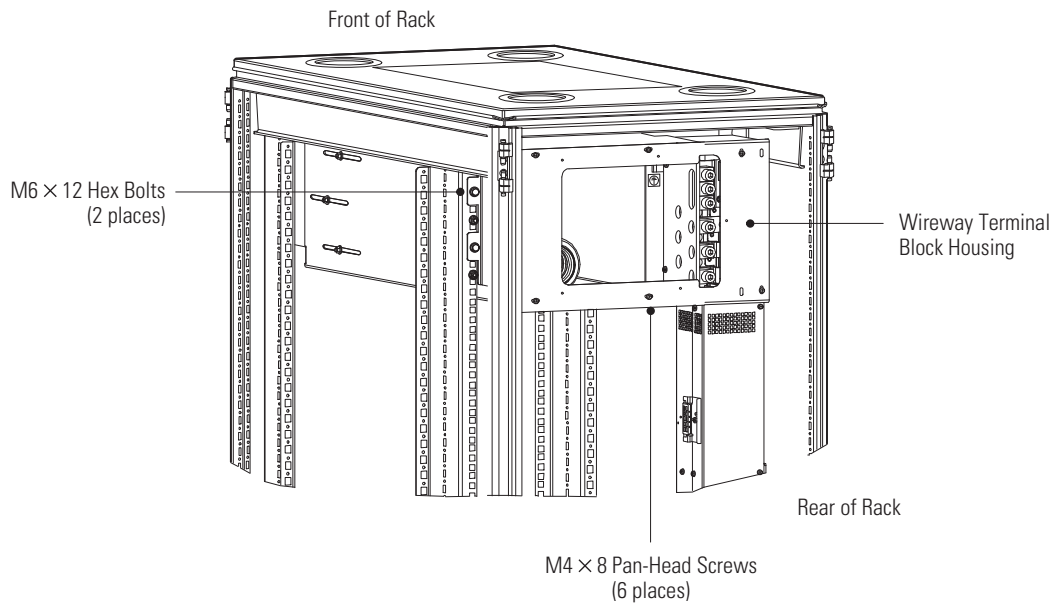

Figure 17. Wireway Terminal Block Housing Installation

NOTE Loosening the mounting brackets slightly may allow easier alignment to the vertical rail of the rack. Retighten the mounting brackets when alignment is complete.

22. Using five M4 x 8 pan-head screws, install the wireway access cover. See Figure 18. Torque the screws to $1.7 \pm 0.2 \text{ Nm}$ ($15 \pm 2 \text{ lb in}$).

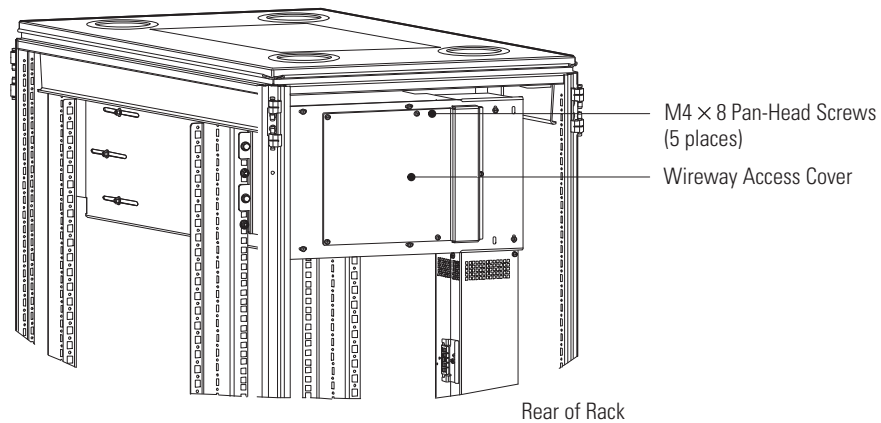

Figure 18. Wireway Access Cover Installation

23. Verify that the six information labels are attached to the wireway as shown in Figure 19.

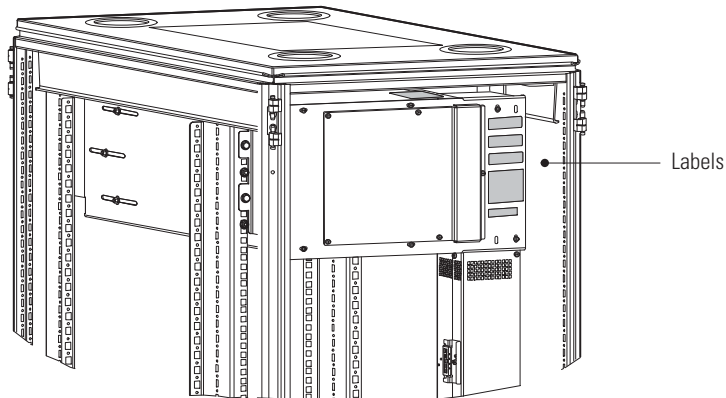

Figure 19. Wireway Labels

24. Using four M5 x 16 hex bolts and four M5 cage nuts, secure the front cover mounting panel to the front of the rack. Ensure that the bent edge of the panel is at the top. See Figure 20.

Install the upper bolts and cage nuts into the second holes from the top of the rack frame. Torque the bolts to 5.1 ± 0.8 Nm (45 ± 7 lb in).

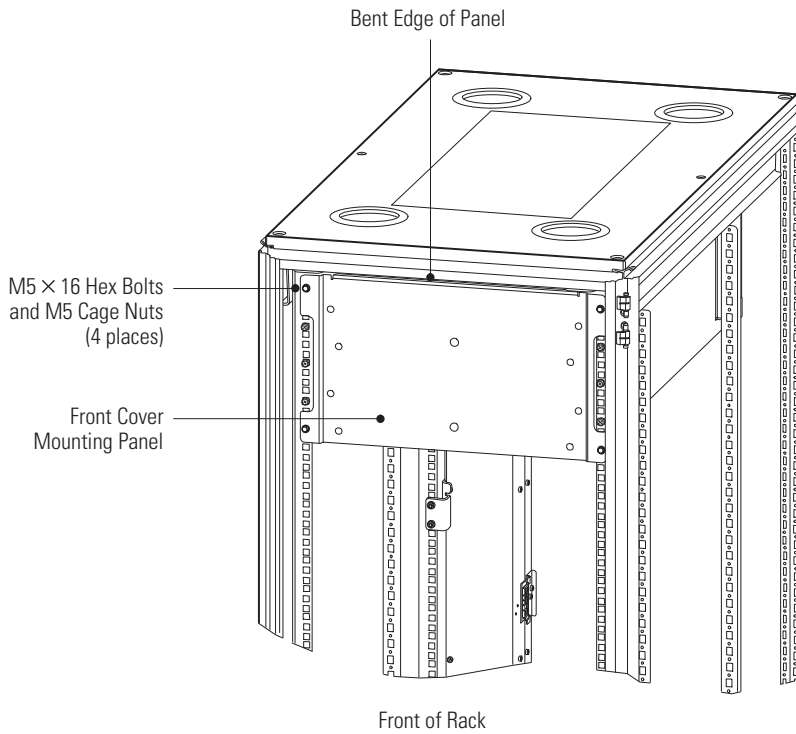

Figure 20. Front Cover Mounting Panel Installation

25. Snap the two front covers into place, as shown in Figure 21.

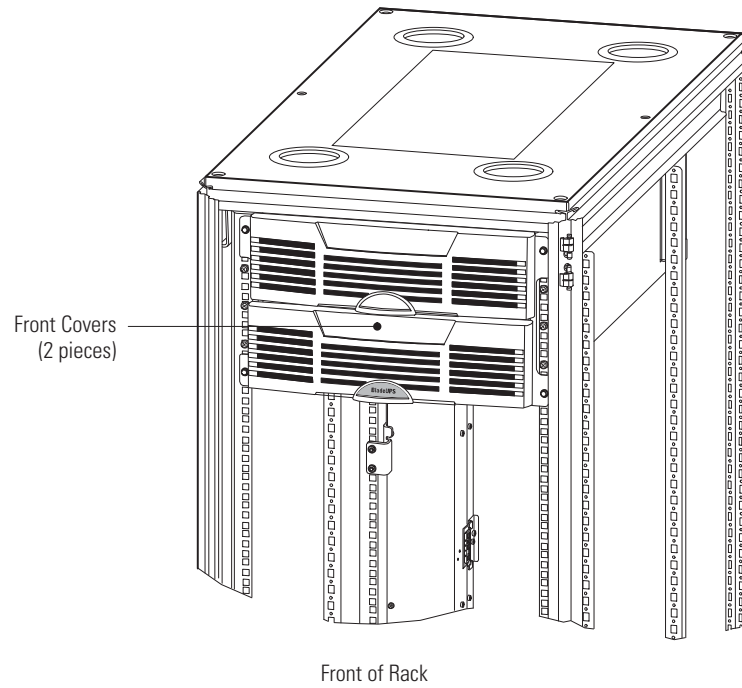

Figure 21. Front Cover Installation

This page intentionally left blank.

Chapter 3 Specifications

This section provides the following specifications:

Table 1. BladeUPS Bar

	BladeUPS Bar 3-High	BladeUPS Bar 4-High	BladeUPS Bar 6-High
Dimensions (W x D x H)	152 x 145 x 1118 mm (6.0" x 5.7" x 44.0")	152 x 145 x 1296 mm (6.0" x 5.7" x 51.0")	152 x 145 x 1829 mm (6.0" x 5.7" x 72.0")
Depth of Wireway	901 mm (35.5"), excluding front covers		
Weight	BladeUPS Bar: 15.9 kg (35 lb) Wireway enclosure: 20.4 kg (45 lb) Total weight: 36.3 kg (80 lb)	BladeUPS Bar: 18.1 kg (40 lb) Wireway enclosure: 20.4 kg (45 lb) Total weight: 38.5 kg (85 lb)	Power Xpert Gateway PXGX PDP Card Bar: 24.5 kg (54 lb) Wireway enclosure: 20.4 kg (45 lb) Total weight: 44.9 kg (99 lb)
UPS Connections	Up to 3, using Anderson input/output connectors	Up to 4, using Anderson input/output connectors	Up to 6, using Anderson input/output connectors
Rack Placement	Bottom wireway fits into the bottom 6U of standard rack space. Top wireway fits into the top 6U of standard rack space.		

This page intentionally left blank.

Chapter 4 Service and Support

If you have any questions or problems with the BladeUPS Bar, call your **Local Distributor** or the **Help Desk** at one of the following telephone numbers and ask for a UPS technical representative.

Installation support (toll free)

United States: **1-800-356-5737, Option 2** then **Option 2** again for BladeUPS

Canada: **1-800-461-9166 ext 260**

All other countries: **Call your local service representative**

Operation support (toll free)

Standard operation support is provided by UPS technical representatives during regular business hours. On-call technical support is provided after hours for emergencies only. Use the toll-free telephone number provided above.



NOTE

Installation and standard operation support is provided during the following regular business hours:

Monday–Thursday: 8 a.m. to 7 p.m. Eastern Standard Time (EST)

Friday: 8 a.m. to 6 p.m. Eastern Standard Time (EST)

Please have the following information ready when you call the Help Desk:

- Model number
- Serial number
- Version number (if available)
- Date of failure or problem
- Symptoms of failure or problem
- Customer return address and contact information

If repair is required, you will be given a Returned Material Authorization (RMA) Number. This number must appear on the outside of the package and on the Bill Of Lading (if applicable). Use the original packaging or request packaging from the Help Desk or distributor. Units damaged in shipment as a result of improper packaging are not covered under warranty. A replacement or repair unit will be shipped, freight prepaid for all warrantied units.



NOTE

For critical applications, immediate replacement may be available. Call the **Help Desk** for the dealer or distributor nearest you.

This page intentionally left blank.

Chapter 5 Warranty

Limited Warranty (Global)

Eaton® UPS Model: BladeUPS® (Global)

WARRANTOR: The warrantor for the limited warranties set forth herein is Eaton Corporation, an Ohio Corporation ("Eaton").

LIMITED WARRANTY: This limited warranty (this "Warranty") applies only to the original Purchaser (the "End-User") of any Eaton BladeUPS Products (individually and collectively, the "Product") purchased and registered with Eaton and cannot be transferred. This restriction applies even in the event that the Product is initially sold by Eaton for resale to an End-User. This Warranty gives you specific legal rights, and you may also have other rights which vary from State to State (or jurisdiction to jurisdiction).

LIMITED WARRANTY PERIOD: The period covered by this Warranty for the Product is eighteen (18) months from the date of Product shipment.

WHAT THIS LIMITED WARRANTY COVERS: Eaton warrants that the Product and battery (individually and collectively, the "Warranted Items") are free of defects in material and workmanship. If, in the opinion of Eaton, a Warranted Item is defective and the defect is within the terms of this Warranty, Eaton's sole obligation will be to repair or replace such defective Warranted Item (including providing service, parts and labor, as applicable), at the option of Eaton.

PROCEDURES FOR REPAIR OR REPLACEMENT OF WARRANTED ITEMS: The Warranted Item will be repaired or replaced at an Eaton site or such other location as determined by Eaton.

If the Warranted Item is to be replaced by Eaton, and the End-User supplies a credit card number or purchase order for the value of the replacement product, Eaton will use commercially reasonable business efforts to ship (via standard ground shipment and at no cost to the End-User) the replacement Warranted Item to the End-User within one (1) business day after Eaton receives notice of the warranty claim. In such case, the End-User must return (at Eaton's expense) the defective Warranted Item to Eaton in the same packaging as the replacement Warranted Item received by the End-User or as otherwise instructed by Eaton. If Eaton does not receive the defective Warranted Item, Eaton will either charge the End-User's credit card, or send the End-User an invoice (which the End-User agrees to pay), for the value of the replacement product.

If the Warranted Item is to be replaced by Eaton, but the End-User is unwilling or unable to supply a credit card number or purchase order for the value of the replacement product, Eaton will use commercially reasonable business efforts to ship (via standard ground shipment and at no cost to the End-User) the replacement Warranted Item to the End-User within one (1) business day after Eaton receives the defective product from the End-User.

In any case, Eaton will provide shipping instructions and will pay its designated carrier for all shipping charges for return of defective equipment and replacement of Warranted Items. Any returned Warranted Item or parts that are replaced may be new or re-conditioned. All Warranted Items returned to Eaton and, in any replacement endeavor, all parts removed by Eaton shall become the property of Eaton.

WHAT THIS LIMITED WARRANTY DOES NOT COVER: This Warranty does not cover any defects or damages caused by: (a) failure to properly store the Product before installation, including the charge of batteries no later than the date indicated on the packaging; (b) shipping and delivery of the Product if shipping is FOB Factory; (c) damage caused by fire, flood, lightning, vandalism, acts of God, End-User's neglect, misuse, misapplication, incorrect connection, or external damage, or that has been subject to repair or alteration by End-User (or a third party) not authorized by Eaton in writing; (d) repair or alteration not performed by an authorized Eaton Customer Service Engineer or Agent; (e) improper testing, operation, maintenance, adjustment, or modification of any kind not authorized in writing by Eaton personnel or performed by an authorized Eaton Customer Service Engineer or Agent; or (f) use of the Product under other than normal operating conditions or in a manner inconsistent with the Product's labels or instructions.

This Warranty is not valid if the Product's serial numbers have been removed or are illegible. Any Warranted Items repaired or replaced pursuant to this Warranty will be warranted for the remaining portion of the original Warranty subject to all the terms thereof.

Eaton shall not be responsible for any charges for testing, checking, removal, or installation of Warranted Items.

EATON DOES NOT WARRANT EQUIPMENT NOT MANUFACTURED BY EATON. IF PERMITTED BY THE APPLICABLE MANUFACTURER, EATON SHALL PASS THROUGH SUCH MANUFACTURER'S WARRANTIES TO END-USER.

EATON DOES NOT WARRANT SOFTWARE, INCLUDING SOFTWARE EMBEDDED IN PRODUCTS, THAT IS NOT CREATED BY EATON. WITHOUT LIMITING THE FOREGOING, EATON SPECIFICALLY DOES NOT WARRANT SOFTWARE (SUCH AS LINUX) THAT WAS CREATED USING AN "OPEN SOURCE" MODEL OR IS DISTRIBUTED PURSUANT TO AN OPEN SOURCE LICENSE.

THIS WARRANTY IS THE SOLE AND EXCLUSIVE WARRANTY OFFERED BY EATON WITH RESPECT TO THE PRODUCTS AND SERVICES AND, EXCEPT FOR SUCH FOREGOING WARRANTY, EATON DISCLAIMS ALL OTHER WARRANTIES INCLUDING, BUT NOT LIMITED TO, ANY IMPLIED WARRANTIES OF MERCHANTABILITY, TITLE, NON-INFRINGEMENT, AND FITNESS FOR A PARTICULAR PURPOSE. CORRECTION OF NON-CONFORMITIES IN THE MANNER AND FOR THE PERIOD OF TIME PROVIDED ABOVE SHALL CONSTITUTE EATON'S SOLE LIABILITY AND END-USER'S EXCLUSIVE REMEDY FOR FAILURE OF EATON TO MEET ITS WARRANTY OBLIGATIONS, WHETHER CLAIMS OF THE END-USER ARE BASED IN CONTRACT, IN TORT (INCLUDING NEGLIGENCE OR STRICT LIABILITY), OR OTHERWISE. SOME STATES OR JURISDICTIONS DO NOT ALLOW THE EXCLUSION OF EXPRESS OR IMPLIED WARRANTIES, SO THE ABOVE EXCLUSION MAY NOT APPLY TO YOU. IN THAT EVENT, SUCH WARRANTIES ARE LIMITED IN DURATION TO THE LIMITED WARRANTY PERIOD. SOME STATES OR JURISDICTIONS DO NOT ALLOW LIMITATIONS ON HOW LONG AN IMPLIED WARRANTY LASTS OR THE EXCLUSION OR LIMITATION OF INCIDENTAL OR CONSEQUENTIAL DAMAGES, SO THE ABOVE LIMITATIONS AND/OR EXCLUSIONS MAY NOT APPLY TO YOU.

LIMITATION OF LIABILITY: The remedies of the End-User set forth herein are exclusive and are the sole remedies for any failure of Eaton to comply with its obligations hereunder. In no event shall Eaton be liable for any indirect, incidental, special, or consequential damages of any kind or type whatsoever, resulting from, or in connection with, any claim or cause of action, whether brought in contract or in tort (including negligence or strict liability). Some States or jurisdictions do not allow the exclusion of limitation of incidental or consequential damages, so the above limitation or exclusion may not apply to you. Eaton shall not be responsible for failure to provide service or parts due to causes beyond Eaton's reasonable control. In no case will Eaton's liability under this Warranty exceed the replacement value of the Warranted Items.

END-USER'S OBLIGATIONS: In order to receive the benefits of this Warranty, the End-User must register the product warranty (via mail or online at www.eaton.com/powerquality "Register a Product"); use the Product in a normal way; follow the Product's operation and maintenance manual; and protect against further damage to the Product if there is a covered defect.

OTHER LIMITATIONS: Eaton's obligations under this Warranty are expressly conditioned upon receipt by Eaton of all payments due from End-User (including interest charges, if any). During such time as Eaton has not received payment of any amount due to it for the Product, in accordance with the contract terms under which the Product is sold, Eaton shall have no obligation under this Warranty. Also during such time, the period of this Warranty shall continue to run and the expiration of this Warranty shall not be extended upon payment of any overdue or unpaid amounts.

COSTS NOT RELATED TO WARRANTY: The End-User shall be invoiced for, and shall pay for, all services not expressly provided for by the terms of this Warranty, including without limitation, site calls involving an inspection that determines no corrective maintenance is required. Any costs for replacement equipment, installation, materials, freight charges, travel expenses, or labor of Eaton representatives outside the terms of this Warranty will be borne by the End-User.

OBTAINING WARRANTY SERVICE: In the United States, call the Customer Reliability Center 7x24 at 800-356-5737. Outside of the United States, contact your local Eaton product sales or service representative. For comments or questions about this Warranty, write to the Customer Quality Representative, 3301 Spring Forest Road, Raleigh, North Carolina 27616 USA.

This page intentionally left blank.



164201723 3