

Variable frequency drives: energy savings for pumping applications

Tom Neuberger and
Steven B. Weston,
Eaton Corporation

Variable frequency drives application and use

In the early days of variable frequency drive (VFD) technology, the typical application was in process control for manufacturing synthetic fiber, steel bars, and aluminum foil. Because VFDs improved process performance and reduced maintenance costs, they replaced motor generator sets and DC drives. When the energy crisis occurred in the early 1970s, saving energy became a critical goal, and the use of VFDs quickly spread into large pump applications and eventually into HVAC fan systems.

Variable frequency drives compared to throttling devices

In many flow applications, a mechanical throttling device is used to limit flow. Although this is an effective means of control, it wastes mechanical and electrical energy. **Figure 1** represents a pumping system using a mechanical throttling valve and the same system using a VFD.

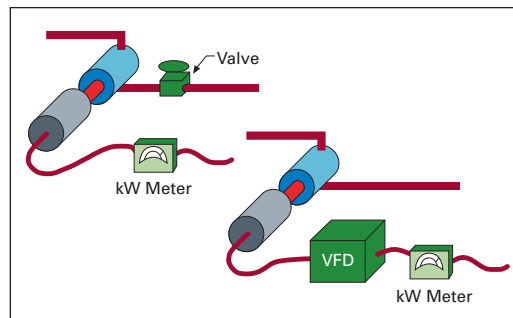

Figure 1. A Mechanical Throttling Device versus a VFD

If a throttling device is employed to control flow, energy usage is shown as the upper curve in **Figure 2**, while the lower curve demonstrates energy usage when using a VFD. Because a VFD alters the frequency of an AC motor, speed, flow, and energy consumption are reduced in the system. The energy saved is represented by the green shaded area.

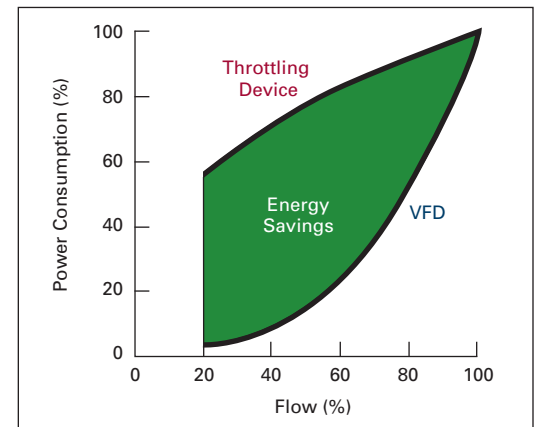

Figure 2. The Amount of Energy Saved by Using a Variable Frequency Drive (versus a Valve) to Control Flow

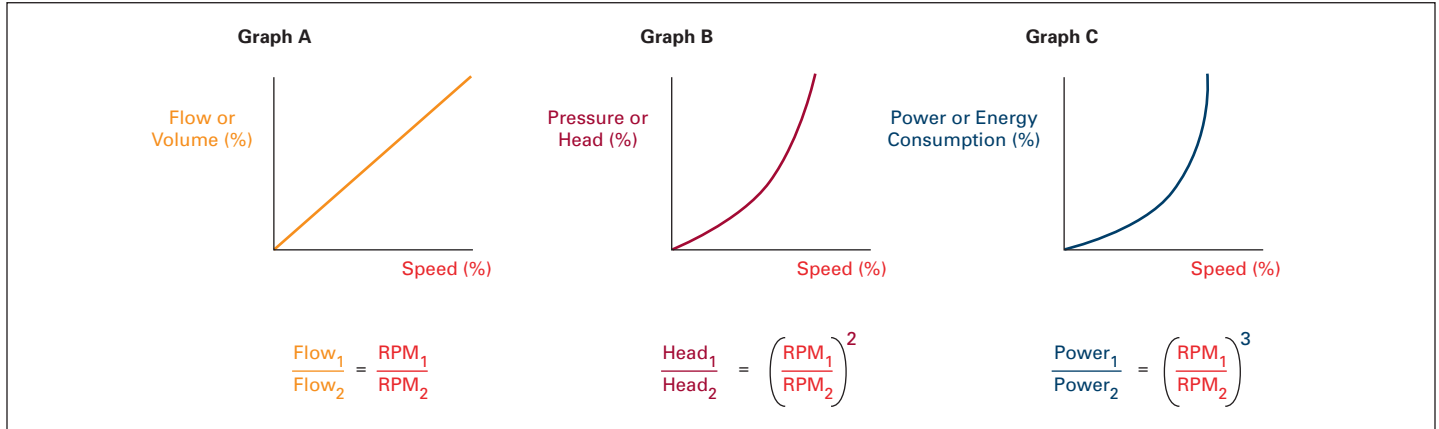

Figure 3. The Affinity Laws

Variable frequency drives theory

The affinity laws can determine the system performance for centrifugal devices, including theoretical load requirements and potential energy savings. Represented in **Figure 3** are the three affinity laws:

1. Flow or volume varies linearly with speed. If speed decreases by 50%, flow decreases by 50% (**Graph A**).
2. Pressure or head varies as a square of the speed. If speed decreases by 50%, the pressure decreases to 25% (**Graph B**).
3. Power or energy consumption varies as a cube of the speed. If speed decreases by 50%, power consumption decreases to 12.5% (**Graph C**). The potential of energy savings is available as the flow requirement is reduced.

Pumping system characteristics

Determining the system curve, which describes what flow will occur given a specific pressure, is critical to selecting the appropriate pump for a system. To determine an accurate system curve, two elements must be known:

- **Static head or lift**—The height that the fluid must be lifted from the source to the outlet.
- **Friction head**—The power required to overcome the losses caused by the flow of fluid in the piping, valves, bends, and any other devices in the piping. These losses are completely flow-dependent and are nonlinear.

In **Figure 4**, the static head, friction head, and resulting system curve are shown for a typical pumping system. In this example, the maximum flow rate required is 160 gallons per minute (gpm). This information helps to determine the required pump and impeller size for the system to provide the maximum required flow. Based on the system curve in **Figure 4**, the pump should develop at least 120 feet of pressure.

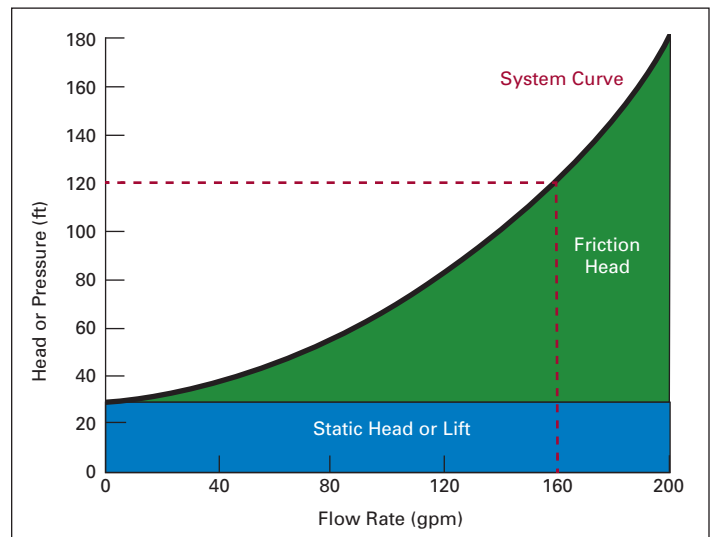

Figure 4. Elements of a System Curve

In **Figure 5**, the system curve and pump performance curve intersect at the desired operating point of 120 ft of pressure and 160 gpm of flow. The system will have a single operating point unless a device is added, and rarely does a pumping application require the pump to produce maximum flow.

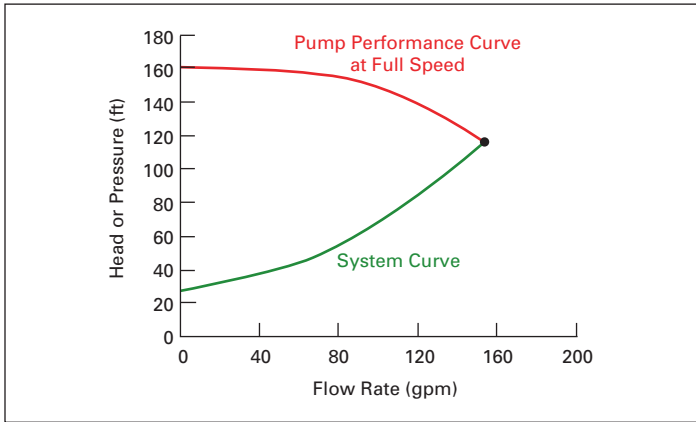

Figure 5. A Combination of the System and Pump Curves

Throttling device application in a pump system

A throttling device is often used as a mechanical method to reduce the flow rate in a pumping system. Applying a throttling device to the system changes the pump curve, as shown in **Figure 6**. This reduces the flow of the system, but the pump curve is not altered and continues to operate at full speed. This creates mechanical stresses—excessive pressure and temperature—on the pump system, which can cause premature seal or bearing failures. More importantly, this also consumes a tremendous amount of energy. The energy consumed is represented by the blue shaded area in **Figure 6**.

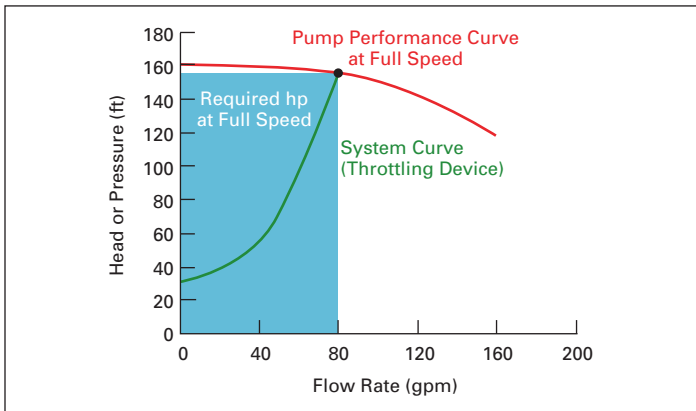

Figure 6. System Characteristics Using a Mechanical Throttling Device

Variable frequency drives application in a pump system

Applying a VFD to the pump allows control of the pump's speed electrically while using only the energy needed to produce a given flow. This is similar to applying a new pump with a smaller impeller. **Figure 7** demonstrates the new pump curve and the energy consumed by this method. Also, the pressure is reduced, which helps reduce the mechanical stresses generated by throttling devices.

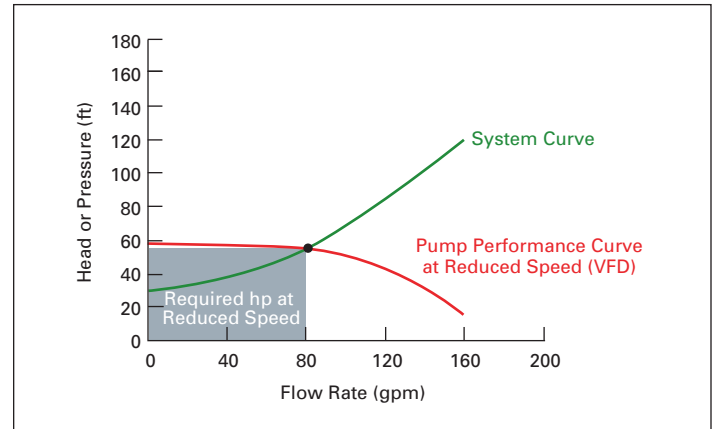

Figure 7. System Characteristics Using a Variable Frequency Drive

Overlaying the two previous graphs, the difference is obvious in **Figure 8**. The blue shaded area is the energy saved by using a VFD instead of a throttling device.

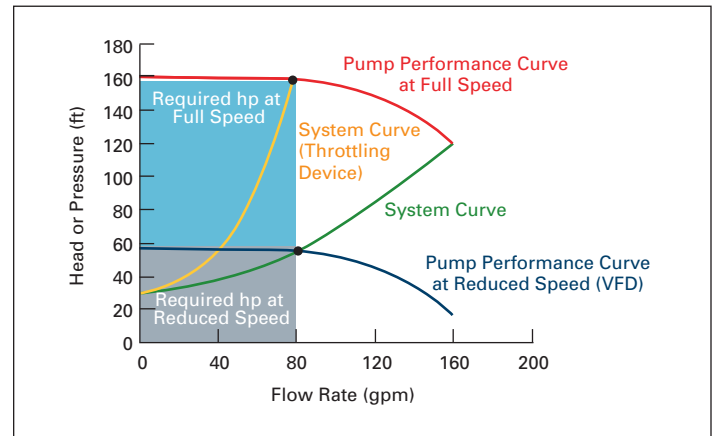

Figure 8. The Difference in Energy Consumption Using a Throttling Device versus a Variable Frequency Drive

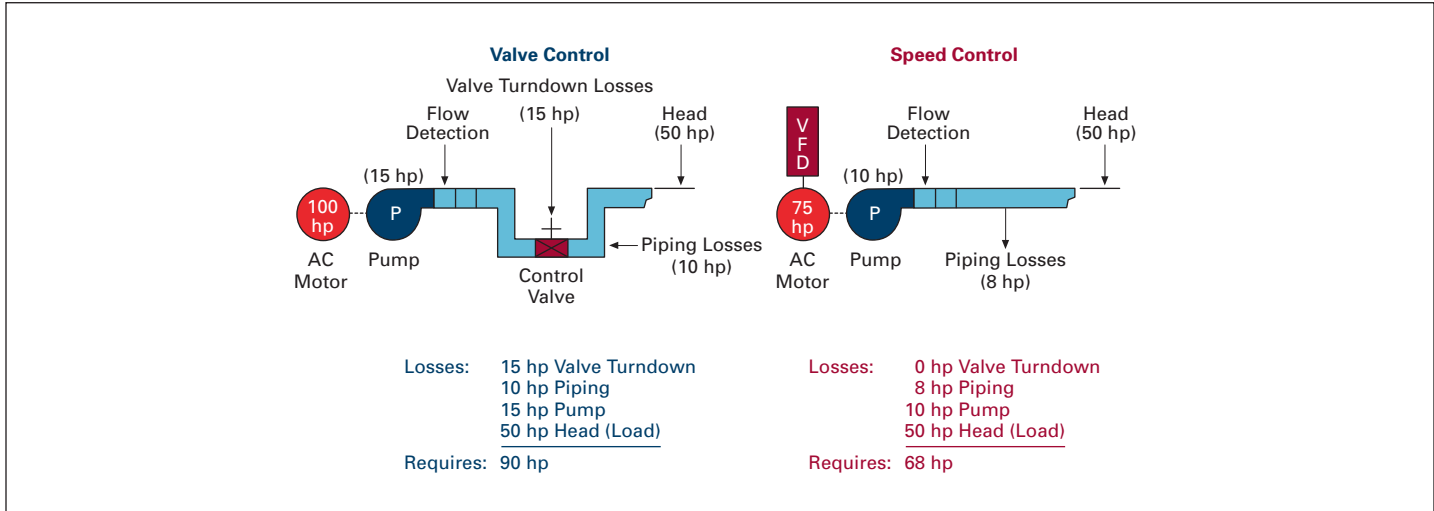

Figure 9. Energy Savings Can Be Calculated with a Computerized Analysis

Variable frequency drives for further cost savings

The use of VFDs can bring further total system cost reductions, due to the elimination of components required for valve control only. In a valve flow control system, there are losses in the valve and additional piping required to bring the valve to a height where it can be adjusted. In the previous example, the piping loss is 10 hp, and the valve loss is 15 hp.

Because of these losses and the internal pump loss, to obtain a head equivalent to 50 hp, an equivalent of a 90 hp pump and a 100 hp motor is required. With the use of the VFD, there are no valve or pipe losses due to bends or additional piping, thus reducing the piping losses to 8 hp. With the reduction of these losses, a smaller pump can be used with lower losses. For the same equivalent of 50 hp of head, only a 68 hp pump and a 75 hp motor are required. This results in a substantial system cost and installation savings, further economically justifying the use of the VFD.

Eaton Corporation
 Electrical Sector
 1111 Superior Avenue
 Cleveland, OH 44114 USA
 Eaton.com

© 2012 Eaton Corporation
 All Rights Reserved
 Printed in USA
 Publication No. IA04008002E / Z12581
 November 2012

Eaton is a registered trademark of Eaton Corporation.

All other trademarks are property of their respective owners.