

# PROCESS MODERNIZATION UPGRADE: SELECTING AND INSTALLING A NEW MEDIUM-VOLTAGE MOTOR CONTROL CENTER

Chuck Collins  
Sr. Member, IEEE  
Weyerhaeuser Company  
PO Box 238  
Oglethorpe, GA 31068 USA  
[chuck.collins@weyerhaeuser.com](mailto:chuck.collins@weyerhaeuser.com)

Lawrence B. Farr  
Sr. Member, IEEE  
EverGreen Packaging  
175 Main Street  
Canton, NC 28716 USA  
[Larry.Farr@everpack.com](mailto:Larry.Farr@everpack.com)

David B. Durocher  
Sr. Member, IEEE  
Eaton Corporation  
26850 SW Kinsman Road  
Wilsonville, OR 97070 USA  
[DavidBDurocher@eaton.com](mailto:DavidBDurocher@eaton.com)

**Abstract** - This paper is a case study outlining the selection and installation of a new medium-voltage motor control center (MCC) installed at a major process industrial facility in the USA. The new motor control center was installed as a part of a system expansion addition of four new pumps included in a bleach plant modernization project. The installation included a bus connection to an existing vintage medium-voltage MCC and the addition of a new control center assembled by a different manufacturer than the original equipment. The new installed assembly seemed to represent a shift in technology versus traditional medium-voltage MCC designs, including changes in voltage and current sensing along with motor protection. These new design approaches versus traditional MCC assemblies are reviewed and compared in this paper. Commissioning and operation of the new design presented some challenges to site operations but also offered some unique operational and system protective capabilities that were not available in traditional models previously installed at the mill. The paper will review the bleach plant project and the decision criteria in selecting the new control center. The new MCC will be explained with focus on the hardware differences versus traditional models and system operational deliverables in predictive diagnostics, equipment performance and protection as a result of installing the new medium-voltage MCC on the bleach plant project.

*Index Terms* – Modernization Project, Motor Control Center, Motor Protection, Electronic Protective Device, Vacuum Contactor, Predictive Diagnostics

## I. INTRODUCTION

Weyerhaeuser's Flint River cellulose fibers mill in Oglethorpe, Georgia, was designed, constructed, and started up in the 1970's. It is a basic single-line mill comprised of a wood yard, a continuous digester, washing and bleaching operation, a pulp dryer and roll-handling line, and a utilities area. When originally started, the mill was a 750 Air Dried Metric Tons (ADMT) per day pulp mill to support the diaper business of a major consumer products manufacturer. Through various projects and debottlenecking efforts through the years, production has been raised to over 1,000 ADMT per day. In 2015 a major maintenance shutdown was scheduled that included refurbishment of the recovery boiler. Taking advantage of the planned extended downtime required to replace the top and bottom of the boiler, two other projects

were scheduled and executed during the outages; the addition of a second turbine generator to the power generation and distribution system within the mill and modernization of the existing bleach plant. Both of these projects required the addition of several medium voltage motors and starters. The approach, which will be discussed in later sections of this paper, was different for the two projects.

The facility has been operational for many years and most of the vintage power distribution and control systems are still in use. The site philosophy employed during upgrades has been somewhat unique in that mill engineering and the supporting corporate technical team have consistently been willing to try new technology while driving continuous operational improvements. The result is this mill serves as a platform in support of various technology upgrades. The mill has been a model for the industry in both installing next generation upgrades and also documenting the results in well written and award winning technical papers. Some of these documented upgrades address improved energy efficiency [1], component testing methods to enhance operational reliability [2] and power distribution retrofits to improve electrical workplace safety [3].

The 2015 bleach plant modernization project presented the mill with an opportunity to review their existing medium-voltage motor control center standard and consider changes that might reduce costs while improving functionality and reliability. Remaining true to form, the mill and corporate engineering team considered the alternative of selecting a traditional medium-voltage MCC versus the newer design and ultimately decided on an upgrade. This paper is a case study outlining the mill's experience with this new installation.

## II. PROJECT OVERVIEW

The second turbine generator was a new installation at the Flint River Mill although much of the equipment was purchased used from a company that was closing down a production facility. Since the second turbine generator was a new installation there was no possibility to tie into existing MCC's. To save money four used starters were refurbished and utilized for the medium voltage starter needs on this project.

The bleach plant project which is the case study subject of this paper, involved modernization of the existing bleach plant. The original plant was typical of bleach plants of the era when the mill was constructed. It included a three stage process using atmospheric diffusion washers. The first (D1) and last stage (D2) were chlorination stages and the middle stage was a caustic extraction stage (Eo). The modernization included

the replacement of the D1 and Eo stages with wash presses and the addition of a cross flow tower prior to the first wash press. Fig. 1 shows the new wash press now installed and operational at the mill. Fig. 2 shows the new D2 storage tower. Final bleached pulp is held in this new tower prior to being transported to the pulp machine.



Fig. 1: New Bleach Plant Wash Press stage 1. Rotary drums and motors installed on upper steel platform.

#### A. Decision Criteria

Several factors were considered in selecting the medium voltage starters to utilize in these projects. Those factors included:

- the integration path into the existing or new distributed control system (DCS), the need for process automation
- the configuration and availability of existing medium voltage motor control centers (MCC)
- the funding levels for the project
- the skill level of the existing electrical and instrumentation staff
- the flexibility of the MCC to fit into the existing and future DCS system architecture
- the MCC design features and a desire to avoid obsolescence issues for the foreseeable future.

One prime consideration regarding selection of new MCCs was the distributed control system (DCS) that would be used to support these projects. The existing DCS system, although well maintained, had been out of production for many years and it was increasingly difficult to find parts for repairs when needed. A new DCS system was specified and the design finalized, however the funds for full implementation were not currently available or approved for the project budget. As various projects are implemented the DCS for that area is brought up to the new design. In both the turbine generator and the bleach plant modernization projects, the mill was able to upgrade the DCS system to the new architecture; however for the bleach plant upgrade only the new equipment was included in the upgrade approved budget. The new Cross Flow tower and the two wash presses for the bleach plant D1 and Eo stages were installed using the new DCS system. The

existing D2 atmospheric diffusion washer was left in place and operated through the old DCS system. To maintain consistency of the DCS architecture, the new DCS system was constructed to match the older DCS system in that discrete wiring was utilized for start stop operation as well as for any monitored parameters.



Fig. 2: New Bleach Plant. Final bleached pulp is moved to D2 storage tower prior to entering the pulp machine.

As discussed previously, addition of the second turbine generator involved a new installation. Because the project budget would not support replacement, four used starters were refurbished and utilized for the medium voltage MCC needs on this project. In the bleach plant project all the original medium voltage starters were reused, so there was only need for an additional four starters to support motor loads for the new wash press system. For this system, the new starters would be fed from an existing medium-voltage MCC in the bleach plant electrical room.

The project team for the bleach plant expansion set out to purchase the new MCC's needed to complete the project. With the considerations outlined in this section in mind, the mill engineer looked for a new medium voltage starter that could be integrated into the existing control scheme, but had the capability to take advantage of the new DCS system capabilities when needed. The selected medium voltage starter design fit these criteria. The design utilizes a vacuum contactor with an onboard programmable controller to control starter functions and microprocessor to provide motor

protection. The design included a full complement of input-output modules so it was easy to use discrete wiring control for start/stop functions where the new DCS I/O was not yet available. Analog output modules provided an easy path to send motor current readings to the existing DCS system. The new medium voltage starter system also offered the capability of viewing and controlling the starters from a central display module (CDM) mounted at the MCC assembly. This allowed mill operations to realize most of the benefits for control of the starters that the future DCS communication architecture could provide. The starters could also be programmed and monitored from the CDM and the equipment manuals and schematics viewed from the same CDM.

In June 2014 prior to final purchase, an opportunity presented itself to visit the supplier's plant in the state of North Carolina USA. The visit included a stop at a local paper mill that had installed a beta test unit of the new medium—voltage MCC two years earlier. The mill visit was at the paper producing site of one of this paper's co-authors in Canton, North Carolina. Following the local mill visit, the team went to the supplier's plant for a technical discussion regarding the project needs. After the plant tour the project team selected the next generation design for the bleach plant expansion. The new medium-voltage MCC platform represented a sharp departure from traditional designs, but also seemed to offer many possible benefits. Some of these are discussed in the following sections of this paper.

### III. COMPARING ALTERNATIVES OF MEDIUM-VOLTAGE MCC DESIGNS

#### A. Overview

Since the mid 1970's, commercially available AC medium-voltage motor control centers have included the same fundamental components: an incoming isolation switch, a vacuum contactor coordinated with integral current-limiting fuses, and a protective relay to protect the driven motor load. The medium-voltage motor control centers originally installed at the Flint River mill included these three system components. Because of the vintage of the original starters installed when the mill was constructed, the contactors included in the original medium-voltage MCCs were actually of the air-magnetic air-break design. Sometime in the late 1970's, the original contactors were retrofitted with vacuum contactors which is the standard used today.

Perhaps the most significant change in medium-voltage MCCs over the past 40 years has been the protective relay. Many of the early age protective relays, including those originally installed when the mill was commissioned, used mechanically actuated bi-metals or melting alloy overloads to detect motor current. These have given way to new electronic motor protection relays with sophisticated functionality, monitoring a host of motor and system conditions, plus network connectivity to communicate operating parameters along with "health" status of the electrical systems and the driven load. What used to be referred to as a motor protective relay, progressed to become a microprocessor-based multi-function relay and today has transformed to become an Intelligent Electronic Device (IED). There have been many excellent papers focused on functionality and maintenance of these protective devices including [4] and [5] as examples.

The next generation medium-voltage motor control center installed for this project abandons traditional thinking in most every design area. The manufacturer's original concept behind developing the new design was to simplify use for the operator. It was believed that as motor protective relays have transitioned to become IEDs with significantly improved functionality, they have also become more complex and are burdened with much higher price points. Indeed, costs of today's most sophisticated motor protective relays can exceed the cost of the balance of components included in the entire starter assembly. As the manufacturer conducted multiple user focus group sessions over a number of years, medium-voltage MCC users confirmed they were frustrated with the degree of complexity in currently available IED offerings. It was learned that even though many users specify and purchase IEDs with extensive protective functionality, often times only a limited number of features are actually programmed, the rest are disabled. Field experience proved that in most operational scenarios, large motors would run trouble free for extended periods. During this time, operators would focus on other priorities, losing sight of the protective trip settings and relay functionality. When a trip occurred, the operators, who likely are no longer familiar with the relay, are called upon to determine the cause of trip, interrogating the relay and troubleshooting the system prior to resetting and reenergizing the motor load.

Another issue the manufacturer's design team considered was the trend toward combining the functionality of the power interrupting device with the logic level protective device. Newer designs of medium-voltage vacuum circuit breakers included a single power and protection system consisting of bushing mounted current sensors, an overcurrent protective device and the circuit power interrupting device all combined into a single package. This approach for medium-voltage circuit breakers has proved to reduce the cost and footprint of the component while also improving functionality and performance. Improved protection and device clearing times as discussed in [6] were promising developments. Listed in this section is a summary of some of the most significant differences between traditional medium-voltage MCCs and design developments deployed in the new medium-voltage motor controller. For each, an explanation of advantages and disadvantages recognized by the mill are considered.

#### B. Current Sensing

Most of the microprocessor based motor protective relays available today utilize three traditional current transformers (CTs) for individual 3-phase current sensing. Current Transformers have been applied for current sensing and fault detection of electrical machines for many years. They provide galvanic isolation and allow high bandwidth current measurements. Today's sophisticated multi-function motor protective relays use CTs in conjunction with proprietary algorithms used to calculate positive, negative and zero sequence currents to model the actual temperature of the motor windings. System protective settings to determine parameters such ground fault are now very common. New advanced protective functions in IEDs utilize CTs to sense high frequency components of current to deliver predictive diagnostics capabilities. For instance, several manufacturers now offer motor protective relays that will "learn" the state of a known good motor while it is operating, and then predict a

potential problem such as a failing motor bearing or a broken rotor bar based on changes in the stator high frequency current spectra [7]. While CTs are a tried and true device to measure current, there are limitations. Current transformers must be designed so that they do not saturate while carrying the DC component of the primary motor current. This increases its size and cost. CT response over the current range of a typical induction motor including starting, can be very non-linear.

One example where CT saturation can pose a problem is in a long-accelerating load. In one situation, another US paper mill was experiencing nuisance tripping of a chipper motor during motor start-up. It was determined using oscillography from the motor protective relay that during start-up of the medium-voltage chipper motor, a current phase imbalance was causing the relay to trip, thinking there was a potential problem with the motor winding. It was later determined that saturation of one of the CT's during motor start-up was the culprit. Changing out to a higher accuracy CT resolved the problem, but this came at added expense as the factory supplied C20 class CTs were ultimately replaced with Class C200 CTs. These were physically much larger and required an added auxiliary structure to allow for needed additional space.

The new medium-voltage MCC uses a Rogowski coil instead of a CT for current sensing. The Rogowski coil was first introduced in 1912 and was used to measure magnetic fields. Today, Rogowski coils are typically applied for current measurement and they are replacing CTs in many applications. The Rogowski coil is a uniformly wound coil on a nonmagnetic former of constant cross-sectional area formed in a closed loop. In accordance with Faraday's Law, when a Rogowski coil is placed around a current carrying conductor, the output signal is proportional to the time derivative of the current to be measured (1).

$$V = M \cdot di/dt \quad (1)$$

To obtain a signal proportional to the monitored current, the output signal of the coil must be integrated. So, a traditional Rogowski current transducer includes an integrator circuit to obtain the current and the flux linkage, which is proportional to the stator current as shown in Fig. 3. Similar to a CT, the Rogowski coil offers non-intrusive isolation, but unlike CTs they do not suffer from DC-current saturation effects, and they are highly linear from tens to many thousands of amperes. Rogowski coils offer low inductance resulting in fast response to changing currents and they are immune to electromagnetic interference with no danger from high voltage if a coil is open circuited. Because the device is highly accurate, it is sensitive enough for ground fault detection to 3 amperes without use of a separate ground fault current transformer. The new motor starters include contactor mounted Rogowski coils for line current sensing as a standard. These are relatively simple and inexpensive to manufacture. There are several good papers outlining the advantages of Rogowski current sensors for protective relay application versus traditional iron core CTs, including [8]. One practical advantage for the mill in use of Rogowski current sensing was that if future horsepower upgrades were required, the Rogowski coils did not need to be replaced, unlike CT's that might require a different CT ratio. Another advantage for the manufacturer is the reduction

in different parts required for inventory. For instance, the legacy design using current transformers required up to 11 different styles of each class, with up to 4 different classes of CT's required to cover all possible applications. For the Rogowski sensor module, 3 different styles of 2 different resolutions are required.

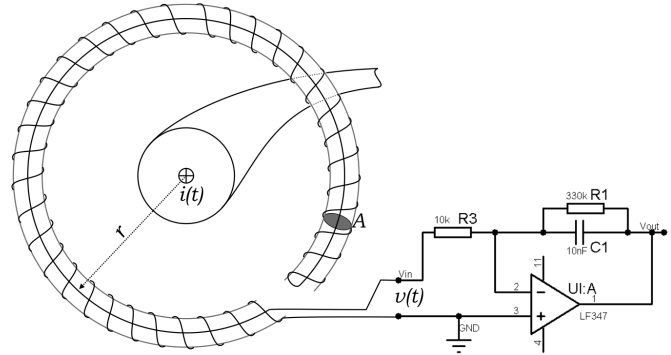

Fig. 3: Typical Rogowski coil offering linear motor protection under any current condition.

### C. Voltage Sensing

Traditional medium-voltage control centers typically utilize separate voltage transformers (VTs) to sense line potential. Because the addition of VTs to each starter in a MCC line-up is typically cost and space prohibitive, one set of VTs is normally applied at the incoming structure where the assembly main metering is installed. If the individual protective relays for each starter include the capability to monitor voltage or power, oftentimes a VT bus will be provided in the line-up. The VT bus essentially hard wire connects the main VTs to the IED mounted in each starter cubicle.

While VTs have historically proved accurate and reliable, there are some potential drawbacks in their application. Most installations require primary and secondary fuse protection along with a primary disconnecting means. These added components require additional space and cost, while potentially compromising reliability. Changing fuses, in particular on the primary side of the VTs, can present a potential shock and/or arc flash hazard which is not desirable. One other potential issue is the possibility of a primary winding failure caused by switching transients. There have been a few recorded incidents of this phenomenon including those discussed in [9]. While this is rare for systems at 5kV and below, it is a possibility.

Newer encapsulated voltage divider components are replacing traditional VTs in many applications. The product design team chose to develop a high voltage element composed of three high resistance elements (mega-ohm range) each in series with a low resistance element (kilo-ohm range). The three-phase assembly is mounted in the sensor module. Encapsulation of the resistors in the module offers excellent heat dissipation and improved dielectric properties. Many tests were conducted to assure safe shutdown should a resistor element be broken. The inherent voltage imbalance protection will cause a trip in the event of a failed resistor element. The motor starters include contactor mounted voltage dividers for each starter unit. Unlike VTs with different



ratings, the voltage divider design requires only one sensor module for all available currents and voltages for the contactor.

**D. Contactor Mounted Motor Protection**

As proved in application of medium-voltage vacuum circuit breakers with integral protective relays, there are several advantages to having the power switching device and the overcurrent protective device included in the same sub-assembly. Traditional medium-voltage MCCs include external wiring to connect the two devices. Protective device wiring between CTs, PTs and the power switching device can be a source of field failures. Most wiring is required to be installed across a hinged door which presents a potential hazard and also compromises reliability. In addition, CT shorting blocks must be attended to prior to removing or testing the relay.

Traditional motor protective relays are available from multiple manufacturers with differing price points and functionality. Although every relay is programmed differently and includes different capabilities in network communications, all are based on a microprocessor controller and algorithms to support defined motor protective functions. Conversely, the new starter design includes the Motor Protective Contactor Controller (MPCC) permanently affixed to the vacuum contactor. This design approach reduces the cost and some potential failure points associated with external wiring of a stand-alone protective relay and the associated current and voltage sensing devices. Fig. 4 shows the traditional and new vacuum contactor in a side by side comparison.

**E. Starter Display and Central Display Modules**

Traditional medium-voltage MCCs include a door mounted overcurrent protective relay, typically mounted on the starter door. In most designs, uploading and changing the protective relay program plus monitoring operating and trip conditions is accomplished via the door-mounted relay. In the new starter, the relay is affixed to the contactor, so a starter display

module (SDM) is used for local programming, control and monitoring. An optional central display module (CDM) is applied to interrogate multiple starters either at the MCC line-up or remote from the assembly in a control room.

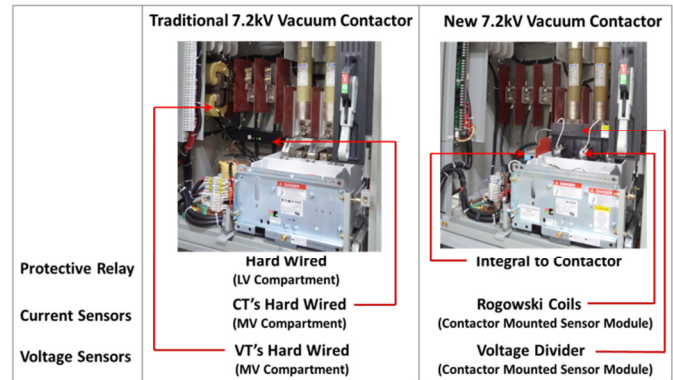

Fig. 4: The new starter vacuum contactor design includes integral current and voltage sensing plus all motor protection functionality.

The door mounted SDM provides local display of motor and starter status and the programmed values. Each contactor mounted protective relay can be programmed or changed by entering individual parameters from the SDM. Like traditional relays, the settings can also be created in a file from a PC and then downloaded through the SDM external port. The SDM includes a Secure Digital (SD) flash memory card that retains the settings for each specific motor. The file can be downloaded from the SD memory card and then adjusted to match any new motor requirements. This makes it simple to change out a SDM and retain the motor protection settings. Fig. 5 shows a connection block diagram from the incoming line to the driven load along with the sensor module, MPCC and SDM used in the new starters.

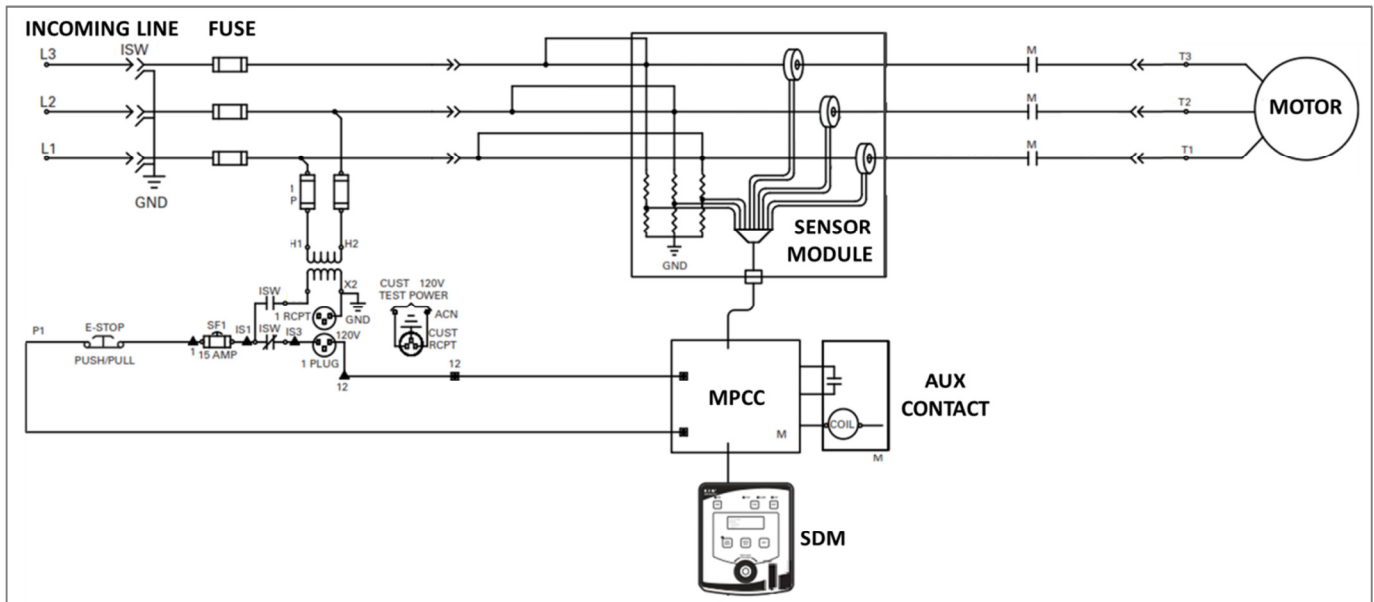

Fig. 5: Connection block diagram shows the main power devices controlling the motor along with the sensor module with Rogowski coils and voltage dividers, motor protective contactor controller (MPCC), auxiliary motor run contact and starter display module (SDM).

The optional CDM communicates to each starter SDM via a Modbus RTU protocol. The CDM consolidates the electrical parameters from all motor loads onto one common display. In addition, functionality such as data trending, alarm reporting and email notification of trip and alarm conditions are supported as standard functionality. The CDM communicates to higher level networks including Ethernet TPC/IP, PROFIBUS, DeviceNet and others. This allows connection to an existing programmable logic controller (PLC) or DCS system for plant supervisory controls. Connectivity to a IEC61850 network [10] is not presently available for the new starter. A network converter would be required to add this functionality, if required.

**F. Enhanced Protection**

For the new medium-voltage MCC design, protective functionality on-board with the contactor saves in both space and cost. Motor protective features are comparable to many of the latest protective relays. Fig. 6 shows a diagram of the various protective functions included in the contactor mounted MPCC based on the IEEE Device Numbers for the various protective functions. Ground protection via zero sequence CTs is required for sensitivity below 3 amperes. The design approach using a contactor mounted controller offers some additional functionality as described below. Traditional MCCs generally do not include these capabilities, although some high-end designs may include some variations on these capabilities.

**Fault Current Detection:** The motor senses the motor starting current and voltage before and during the starting time. An

algorithm calculates the available bolted fault current and arcing fault current for that start.

**Contactor-fuse Coordination:** If the fault is less than the contactor interrupting rating, the starter will identify the fault within 1 cycle (16.7 milliseconds) and the contactor will open without delay in 20 milliseconds. If the fault is greater than the contactor interrupting rating, the contactor will remain closed for up to 130 milliseconds until the fuse clears. The result can be reduced contactor damage and in some cases also saving the expense of replacing fuses along the way.

**Contactor Health:** When the contactor is placed into service a test algorithm determines the pickup and dropout voltages that are required to open and close the contactor. During preventive maintenance cycle, a test program can be run to compare these values to those previously measured, ensuring the contactor is functioning at the original design parameters. Changes from values previously recorded can indicate vacuum loss, incorrect core alignment or other coil problems such as debris on the core face.

**Vacuum Loss:** Should the three-phase contactor lose one vacuum interrupter (VI) the Contactor Health test can pick up the loss of vacuum. Then the other two VIs will be signaled to open, interrupting the load to protect the motor from running with only two of three phases available. If two VI's loose vacuum the Vacuum Loss program will detect that the contactor was told to open and it has not opened. If current continues to flow in two VI's the program recloses the contactor and sends a signal that the starter is in trouble and cannot control the load. This output can be used to open the

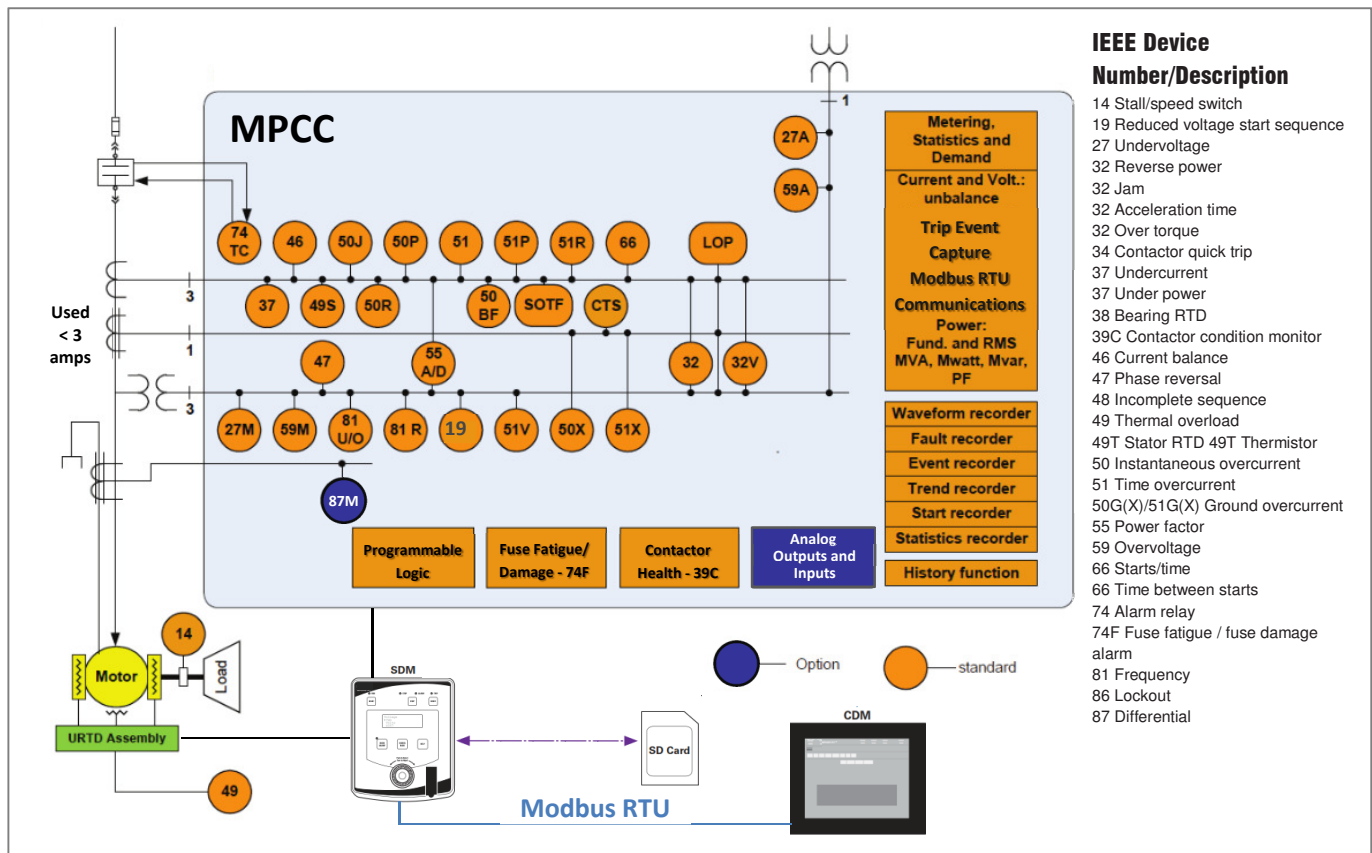

Fig. 6: Protective functions for the new medium-voltage MCC contactor controller based on IEEE Device Numbers and description.

upstream vacuum circuit-breaker before there is significant motor damage.

*Motor Thermal Aging:* The on-board controller compares actual motor temperature to allowable temperature based on machine insulation class. The algorithm calculates the motor thermal life based on actual temperatures over time, helping to pinpoint motor repair or replacement timing to avoid unexpected downtime.

*Fuse Health Algorithm:* "Fuse Fatigue" is displayed after a fuse has experienced a high level of overcurrent. This occurs when 4 or more of the last 20 starts experienced starting currents exceeding 100% of the fuse I<sup>2</sup>T rating. "Fuse Damage" is displayed if a fuse experiences an excessive amount of overcurrent, defined as current exceeding 125% of the fuse I<sup>2</sup>T rating.

*Sensitive Ground Fault Detection:* The high accuracy of Rogowski coils for current sensing allows the controller to calculate ground currents down to 3 amperes. This provides early identification of potential insulation problems or system ground conditions without the need for zero-sequence current transformers. If ground-fault sensitivity below 3 amperes is required, a separate zero-sequence CT can be applied.

#### IV. PROJECT EXECUTION

The primary new electrical motor controls for the bleach plant upgrade included the addition of four new medium-voltage motors. Two 350 horsepower (HP), 4.16 kilo-volt (kV) full voltage non-reversing (FVNR) starters were required for the EOP Wash Press Medium Consistency (MC) pump and Main Hydraulic Pump, one 350HP, 4.16 KV FVNR starter was required for the D1 Wash Press Hydraulic Pump and one 400HP, 4.16kV FVNR starter was required for the D-Stage MC Pump. The mill decided that the best site for the new medium-voltage MCC was an existing electrical equipment room where the legacy pulp washing system controls were presently operating. One early decision was to add the new starter line-up to an existing medium-voltage MCC in the equipment room. There was ample space in the room and adding new starters to the existing line-up, would eliminate the cost of an additional upstream overcurrent protective device.

The existing vintage medium-voltage MCC was very old. The original assembly had been installed when the mill was originally built. Starters in this assembly were of the air-magnetic design with arc-chutes above each phase of the main contactor. The mill's owner at the time was not an advocate of motor overcurrent relays, which at that time were of the rotary disk type design. Because of this, a simple bi-metal overload relay was the only protection for the exiting motors. As mentioned previously, the air-magnetic contactors in the vintage MCCs were replaced with a retrofit vacuum upgrade, supplied by the original manufacturer in the late 1970's. Extending the new starter line-up to the exiting assembly would require a dedicated main bus transition section.

Installation of the new medium voltage starters required two planned maintenance outages. Both of the outages required the MCC to have all power removed. The first outage was utilized to take measurements for the design of an incoming compartment that would connect the new MCC's horizontal

main bus onto an existing MCC horizontal main bus structure. The second outage was used to connect the new starters into the existing starter lineup. The tie-in of the new MCC onto the existing lineup allowed for construction to connect the starters into the DCS system and in some cases field connections to the motor were possible.

The existing bleach plant had to operate normally until the major maintenance shutdown start date was reached. Fortunately, the ability to erect, connect and test equipment prior to the major maintenance shutdown reduced the conversion time line. The conversion, of the bleach plant, was projected to be complete prior to the completion of the recovery boiler refurbishment. This allowed the bleach plant to start up prior to the end of the shutdown period for testing equipment and training of operators.

The manufacturer of the new MCC designed a transition section that bus connected to the original 1970's vintage MCC. Fig. 7. shows the vintage design motor starter structures at the right, with the bus transition structure and then three new structures of the next generation assembly on



Fig. 7: The 1970's vintage MCC structures at the right, followed by a bus transition section and three new MCC structures at the far left.

the right. The main horizontal bus for the vintage assembly was at the center of the structure, whilst the new assembly included main bus at the top. Note that the newly installed MCC includes a flat screen monitor (CDM) as discussed previously, mounted at the top cubicle of structure 1, and starter units in the balance of the cubicles of the new structures. A total of five starters (four active and one spare) were supplied in the new assembly.

Fig. 8 shows the site mill engineer reviewing MCC information from the CDM. The CDM allows all starters to be interrogated from a single display, showing all system parameters including phase currents and voltages, motor load, historical trip/fault history, along with easy access to all drawings including component parts data and individual starter schematics. Fig. 9 shows a detailed time stamped event log that records all system parameters at the time of a trip condition.

The CDM is network connected to each of the starter units via a starter display module (SDM). The SDM is door mounted on the front panel of each starter as shown in Fig. 10.





Fig. 8: Mill engineer stands in front of Central Display Module of the new motor control center.

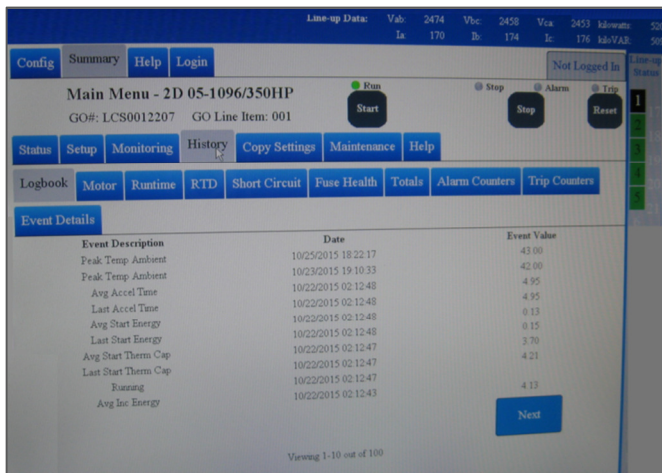

Fig. 9: The Central Display Module shows an event log of all electrical parameters time-stamped based on a past tripping event.

Although each motor can be controlled and monitored from its respective SDM, because of integration to the legacy DCS system discussed previously, the mill opted to add local discrete control devices including a red RUN light, green STOPPED light, HAND-OFF-AUTO selector Switch and an EMERGENCY STOP mushroom type pushbutton. These inputs were hard-wired to the DCS system during the second scheduled outage.

## V. OPERATION AND INSTALLATION CONSIDERATIONS FOR BOTH DESIGNS

In considering the total ownership cost of the new MCC versus a traditional MCC with hard wired electronic protective relays, several key issues are discussed here.

### A. Total Ownership Cost

The new medium voltage MCC supplied compared favorably to other traditional MCC designs in first cost. Costs for installation were calculated to be roughly similar. The power

connections were likely identical, while control wiring was somewhat simplified with the new design as all wiring was connected at the programmable input/output terminals. Operating costs differences are not yet determined due to the fairly short run time for the new control center. There have been no reliability issues to date, so overall things look promising for the mill.

### B. Commissioning

During energization of the new motor controls, the manufacturer's field service organization was responsible for start-up and commissioning. Using the manufacturer's service provider assured that factory trained engineers were there for the start-up and also allowed the mill to take advantage of an extended factory warranty for an additional year. This was a standard offering from the manufacturer. There were no issues during start-up. Traditional design medium-voltage MCCs would have been commissioned in a similar time period. Presuming maintenance personnel were familiar with a comparable traditional MCC, the traditional design may have required marginally less time for commissioning.



Fig. 10: Each starter cubicle includes a starter display module (SDM). Door mounted discrete control devices were included for ease of interface to the existing DCS

### C. Operations/Maintenance/Troubleshooting

Because the mill needed to address the legacy DCS system with hard wired digital and analog inputs and outputs, much of the network functionality of the new MCC was not utilized to its full extent. Mill engineering was happy to install equipment that could support communications via a future DCS system upgrade should funding one day become available. The CDM mounted on the first structure of the new MCC line-up was installed and is operational. So at the MCC, many of the advanced features are today being utilized at a



local level. This is in contrast to traditional designs, although some high-end protective relays offer interface to local or remote Human Machine Interface (HMI) displays similar to the CDM. Considering the short life cycle of many electronics including protective relays, drives and PLC, the modularity of the new system which supported future firmware revisions without the need to replace hardware was considered a major advantage by the mill.

#### D. Training

A special training session was held for the plant operators during the scheduled outage to assure they were familiar with the new controls. Because several electricians were busy with other duties during the outage, attendance of the factory training session was not optimal. Because the new starter technology was new and many operators were not familiar with the hardware, perhaps a traditional design would have an advantage in the area of training the operators. However, newly introduced IEDs typically are introduced with updates in hardware and software. Thus, operators are constantly challenged to learn and be familiar with the latest offerings. With the touch-screen CDM as an option, the manufacturer for the new starter is adding a start-up and troubleshooting video that can be uploaded into the CDM so future maintenance personnel can become familiar with the product operation prior to conducting commissioning or service.

### VI. CONCLUSIONS

While traditional medium-voltage motor control centers that utilize electronic protective relays have delivered increased functionality, they have also suffered from increased complexity at higher costs. In today's global economy, project budgets are restricted across all process industries; forcing industry's engineering community to find new solutions.

Over the course of the past 50 years, electrical assemblies including medium-voltage motor control centers and control gear have changed dramatically. New emerging technologies such as the next generation MCC installed during this project offer a possible alternative path forward for users in the process industries. The new assemblies have fewer parts, are much simpler and more reliable, and they offer enhanced functionality at a lower cost. In many industry applications, this new approach likely renders the traditional electronic motor

protective relay obsolete. Successful installation of the technology installed on this project represents an important step forward: challenging the status quo in driving medium-voltage motor control centers with improved functionality at lower costs toward a more productive future.

### VII. REFERENCES

- [1] W.S Hopper, "Improving Mill Energy Efficiency", *IEEE Industry Applications Magazine*, Nov/Dec 2011.
- [2] Hopper, W., "One Mill's Experience Using MAC Testing to Evaluate Vacuum Interrupter Integrity in 15KV Vacuum Circuit Breakers", 61<sup>st</sup> Annual IEEE IAS Pulp & Paper Industry Conference, 2015
- [3] W.S Hopper, C. Collins, "Mitigating Arc-Flash Hazards: A case study of a mill-wide project", *IEEE Industry Applications Magazine*, May/June 2013.
- [4] C. Wester, T. Smith, T. Fahey, "Commissioning and Periodic Maintenance of Microprocessor-Based Protection Relays at Industrial Facilities", 59<sup>th</sup> Annual IEEE IAS Pulp & Paper Industry Conference, 2013
- [5] Kexing Lai; M.S. Illindala; M.A. Haj-ahmed, "Comprehensive Protection Strategy for an Islanded Microgrid Using Intelligent Relays", *IEEE IAS Annual Meeting*, 2015
- [6] D.B. Durocher, "Unit Substation Design", *IEEE Industry Applications Magazine*, May/June 2011.
- [7] B. Lu, Z. Gao, J. Benzing, "Practical Aspects of Rotor Cage Fault Detection for Medium-Voltage Induction Motors", 60<sup>th</sup> Annual IEEE IAS Pulp & Paper Industry Conference, 2015
- [8] L. Kojovic; M.T. Bishop, "Comparative Characteristics of Iron-Core Current Transformers and Rogowski Coils for Applications for Protective Relaying Purposes" 62nd Annual Conference for Protective Relay Engineers, 2009
- [9] L.B. Farr, D.D Shipp, A.J Smith, P. Goodman, S. Johnston, "Medium Voltage Autotransformer Failures: Explaining the Unexplained - Continuation of the Story", *IEEE IAS Petroleum & Chemical Industry Technical Conference, PCIC-2015-45*
- [10] C. Wester, M. Adamiak, J. Vico, "IEC61850 Protocol - Practical Applications in Industrial Facilities", *IEEE Industry Applications Society Annual Meeting*, 2011