

TLC 5004 - Installation, Operation and Maintenance Manual
Airflex® Torque Limiting Coupling

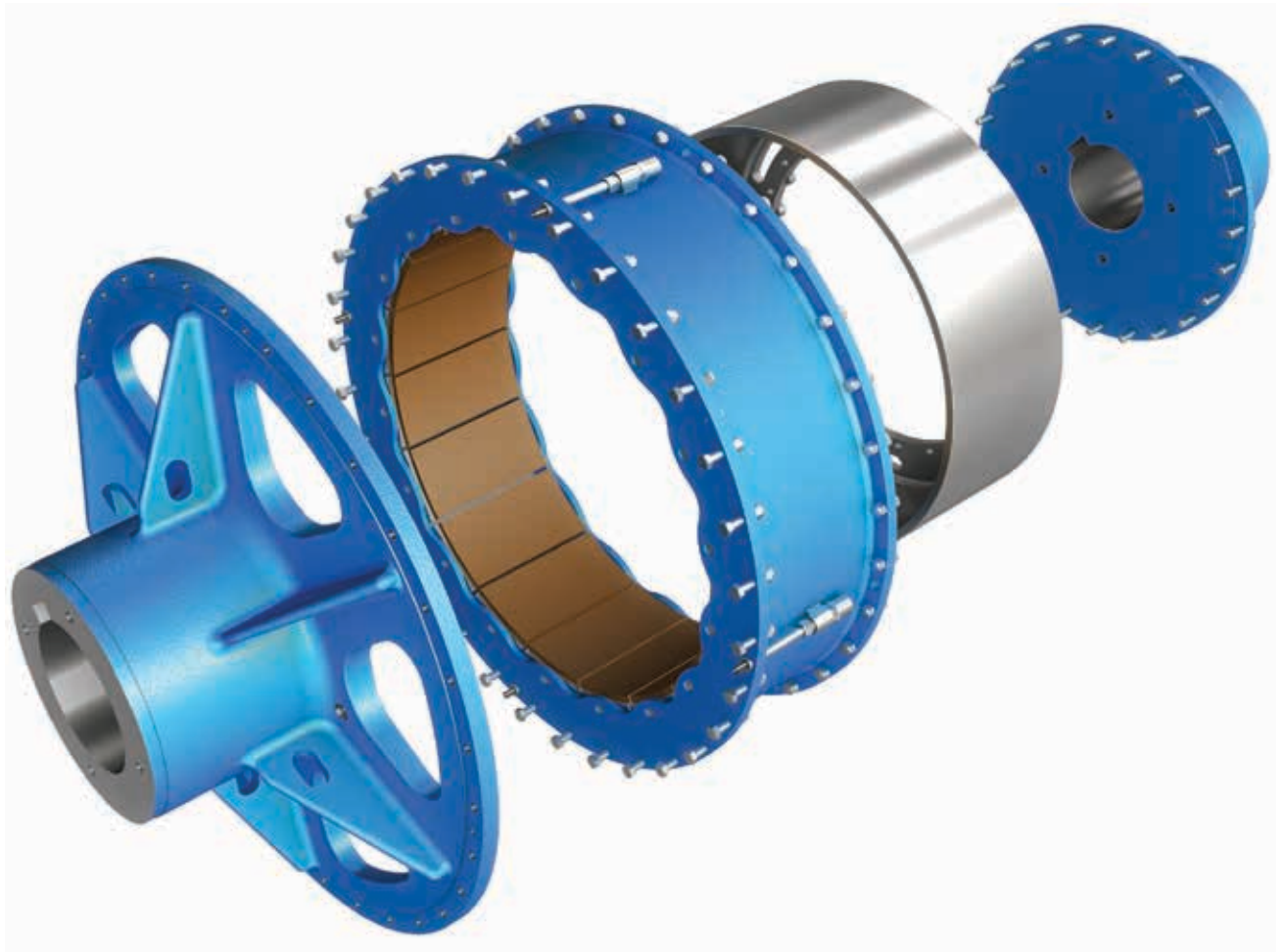

Powering Business Worldwide

Torque Limiting Coupling

General information

Warning

Forward this manual to the person responsible for Installation, Operation and Maintenance of the product described herein. Without access to this information, faulty Installation, Operation or Maintenance may result in personal injury or equipment damage.

Caution

Use Only Genuine Airflex Replacement Parts. The Airflex Division of Eaton Corporation recommends the use of genuine Airflex replacement parts. The use of non-genuine Airflex replacement parts could result in substandard product performance, and may void your Eaton warranty.

For optimum performance, contact Airflex:

In the U.S.A. and Canada: (800) 233-5890

Outside the U.S.A. and Canada: (216) 281-2211

Table of contents

Section	Description	Page no
1.0	Introduction	6
1.1	Description	6
1.2	How it works	6
1.3	TLC adjustment	7
2.0	Installation	7
2.1	Mounting arrangements	7
2.2	Mounting considerations	7
2.3	Mounting spider and drum hub	8
2.4	Shaft alignment	9
2.5	Axial locking device adjustment	10
2.6	Installation of single wide element and drum	11
2.7	Air control system	11
2.8	Electrical controls	11
3.0	Operation	12
3.1	Torque, RPM and Pressure Limits	12
3.2	Control component adjustment	12
4.0	Maintenance	12
4.1	Periodic inspection	12
4.2	Removal of element assembly and drum	14
4.3	Removal of spider and drum hub	14
4.4	Disassembly of the element	14
4.5	Friction shoe assembly replacement	14
4.6	Assembly of the element	15
5.0	Spare parts storage	15
5.1	Element assemblies	15
5.2	Drums	15
5.3	Air actuating tubes	15
6.0	Ordering information/technical assistance	15
6.1	Equipment reference	15
7.1	Parts breakdown of TLC element assemblies figures 1 and 10	16
8.1	Parts breakdown of TLC hub, spider, drum, axial locking assy. and rotor seal figure 2	16
9.1	(Standard) Torque bar kit	17
9.2	(Standard) Friction shoe assembly, torque bar and release spring kit	17
10.1	Description axial locking assembly	17

Torque Limiting Coupling

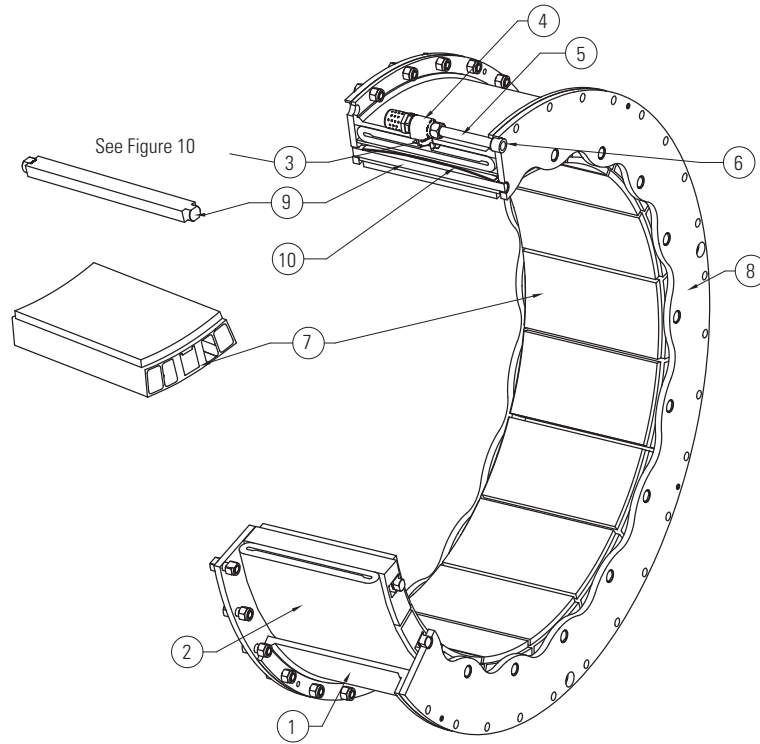

Figure 1

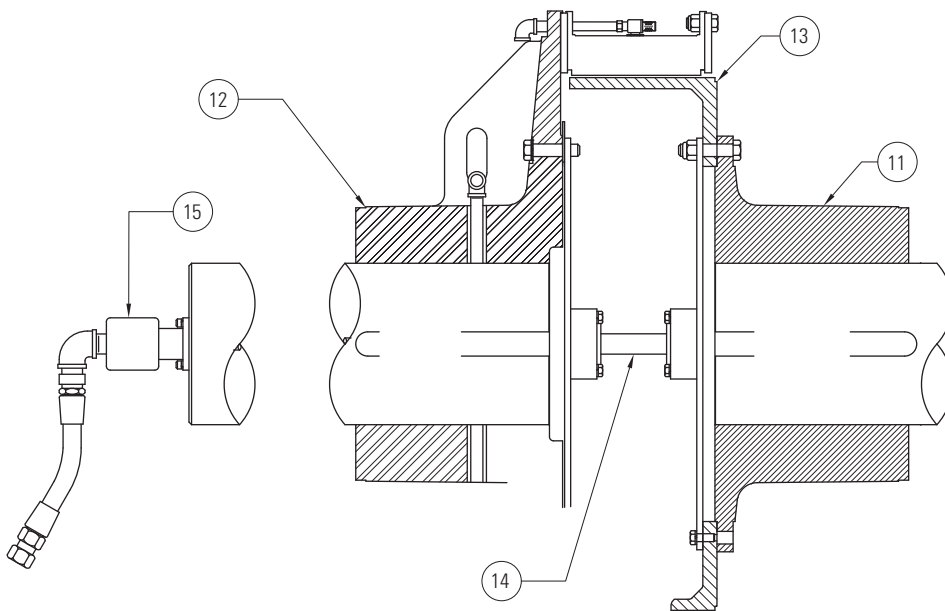

Figure 2

Item	Description	Item	Description	Item	Description
1	Rim	6	Rubber washer	11	Hub
2	Tube	7	Friction shoe assembly	12	Spider
3	Snap rings	8	Side plate (2 required)	13	Drum
4	QRV	9	Torque bar	14	Axial locking assembly
5	Air tube	10	Release spring	15	Rotorseal

Torque Limiting Coupling

Friction shoe assembly retracted

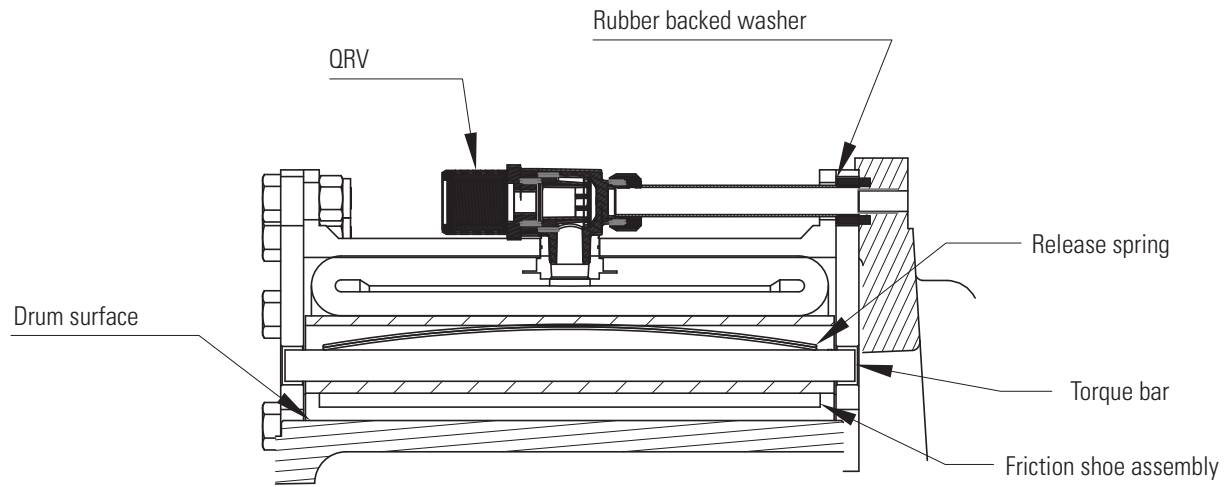

Figure 3

Friction Material in contact with the drum

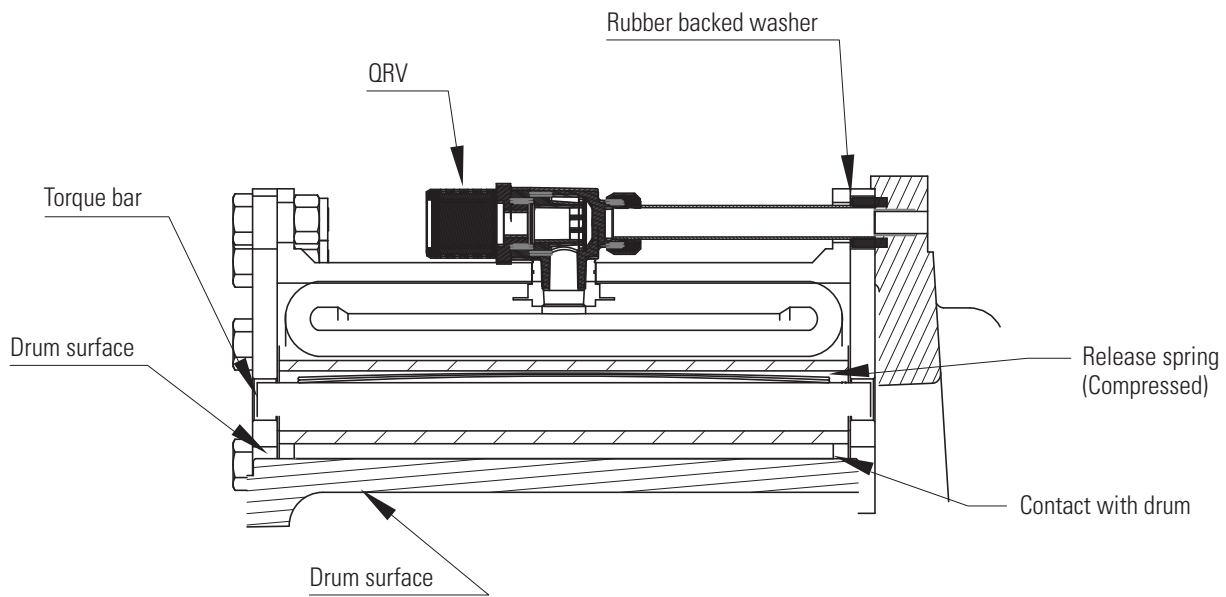

Figure 4

Torque Limiting Coupling

1.0 Introduction

Throughout this manual there are a number of HAZARD Warnings that must be read and adhered to in order to prevent possible personal injury and/or damage to equipment. Three signal words

⚠ Danger, **⚠ Warning** and **⚠ Caution** are used to indicate the severity of a hazard, and are preceded by the safety alert symbol



Danger

Denotes the most serious hazard, and is used when serious injury or death WILL result from misuse or failure to follow specific instructions.



Warning

Used when serious injury or death MAY result from misuse or failure to follow specific instructions.



Caution

Used when injury or product/ equipment damage may result from misuse or failure to follow specific instructions.

It is the responsibility and duty of all personnel involved in the installation, operation, and maintenance of the equipment on which this device is used to fully understand the Danger, the Warning and the Caution procedures by which hazards are to be avoided.

1.1 Description

1.1.1 The Airflex Torque Limiting Coupling (TLC) is air actuated and specifically designed and manufactured for service in grinding mill and other torque limiting applications. Torque limiting is required by variable speed grinding mills directly coupled by the TLC to the mill drive train to prevent damage to the entire drive system from unintended torque spikes or overloading conditions. The TLC provides a means to immediately disengage the mill from the motor(s) when the torque required to drive the mill is excessive and detected by the TLC system. The constricting design and construction make the TLC high torque capacity possible.

In these applications, the TLC will be engaged by applying the specified air pressure when the drive system is at rest. The mill is started from this static condition by the drive(s) and over time brought up to the nominal operational speed. For overload conditions above the rated set point of the TLC it begins to slip resulting in a differential of speeds between the driving and driven shafts. At a predetermined level of slippage based on rpm, the TLC controls disengage the TLC element(s) instantaneously by releasing the applied air pressure.

1.1.2 All Airflex TLC elements are supplied with long wearing, NON-ASBESTOS high coefficient friction material. The material is capable of withstanding the energy input that is developed during the short overload condition when slippage occurs between the driving and driven shaft before the automatic disengagement of the element(s) by the control system.

1.1.3 Airflex TLC element assemblies are now available in sizes from a 51TLC1600 through a 76TLC2000. The element size designation indicates the nominal drum diameter in inches, the TLC model and the width of the high coefficient friction material. For example, size "51TLC1600" indicates the element operates on a drum having a nominal diameter of 51 inches and has friction material which is 16 inches in width.

1.2 How it works

1.2.1 Referring to Figures 1, 2, 3 and 4, the neoprene and cord actuating tube is contained within a steel rim which is drilled for mounting to the driving component. As air pressure is applied to the air actuating tube, the tube inflates, forcing the friction shoe assemblies uniformly against the drum, which is attached to the driven component. The friction shoe assemblies, which consist of the special high coefficient friction pads bonded to aluminum backing plates, are guided by torque bars which are inserted into the element side plates. The torque path is from the driving shaft, through the element mounting component (typically an iron spider), through the element rim and side plates and the torque bars, backing plates and friction material. The torque is then transmitted through the friction couple to the driven shaft. When the specified applied air pressure is exhausted, release springs and centrifugal force assure immediate and positive disengagement.

1.2.1.1 In some cases, the spider and element assembly may be mounted to the driven shaft rather than the driving shaft. This "reverse-mounted" arrangement is typically used when retrofitting a mill drive and it is more practical to drill the pinion shaft for the air supply rather than the motor shaft. In these cases, the operation and torque flow description is opposite to what is stated above.

1.2.1.2 For TLC applications that are mounted to the drive motor(s) an axial locking device is used to hold the motor on magnetic center during operation. Refer to the INSTALLATION section for axial locking device adjustment.

Torque Limiting Coupling

1.3 TLC adjustment

- 1.3.1 The Airflex TLC is completely self-adjusting and automatically compensates for lining and drum wear. Air line lubrication or any other type of lubrication is not required. The torque developed is dependent upon rotating speed and applied air pressure. By limiting the applied pressure, the element will act as a torque limiting device and provide overload protection.

2.0 Installation



Warning

Only qualified personnel should install, adjust or repair these units. Faulty workmanship will result in exposure to hazardous conditions or personal injury.



Caution

Do not inflate the element without having a drum in place. Inflation of the element without a drum in place will result in permanent damage to the element components.

2.1 Mounting arrangements

- 2.1 Airflex TLC applications are available in a single-wide mounting configuration. See Figure 5. The TLC configuration is determined by the motor horsepower, nominal full motor RPM, the allowable motor overload (service factor) for mill start up and operation. All TLC's are supplied with axial locking devices.

2.2 Mounting considerations

- 2.2.1 Shaft alignment must be within the tolerances indicated in the Alignment section of this manual.



Caution

Operation with shaft misalignment exceeding the limits indicated in this manual will result in accelerated wear of the TLC components.

- 2.2.2 The element must be protected from contamination from oil, grease or excessive amounts of dust.



Caution

Oil or grease contamination will result in a reduction of developed torque. Excessive dust contamination may result in incomplete engagement. Either of these conditions will result in a loss of TLC torque and slippage and the controls will disengage the TLC(s).



Caution

All rotating equipment must be guarded to comply with applicable safety standards.

Single-Wide Mounting

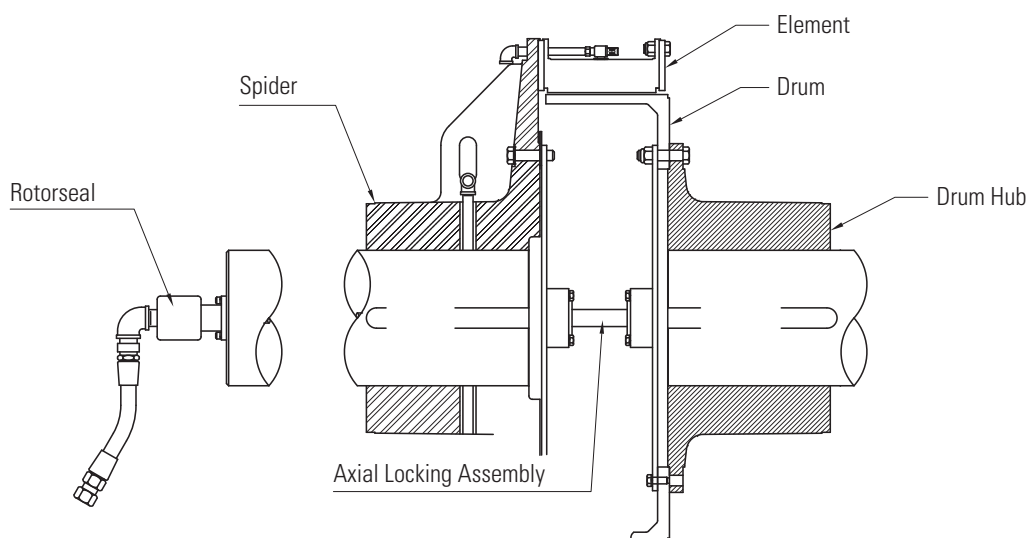

Figure 5

Torque Limiting Coupling

2.2.3 All mounting fasteners must be of the proper size and grade, and torqued to the appropriate value. See Table 1.



Warning

Use only the proper grade and number of mounting fasteners. Using commercial grade fasteners (Grade 2) in place of Grade 8 fasteners (where called for) may result in failure under load, causing personal injury or equipment damage.

2.3 Mounting spider and drum hub

2.3.1 The spider and drum hub are bored for a press fit onto their respective shafts. The interference is approximately 0.0005 inch per inch (0.0005 mm/mm) of shaft diameter.

2.3.2 Ensure the shaft is clean and free of nicks or burrs and check the shaft and bore diameters for proper fit dimensions and are also clean and free of nicks and burrs. Tap the key into the keyway, making sure it bottoms, and apply a light coat of light weight oil to the shaft and key.

2.3.3 Heat the drum hub or spider uniformly to a maximum of 250°F (121°C) to expand the bores.



Caution

It is recommended the drum hub or spider be heated in oil or an oven; however, torches may be used. Use several with "rosebud" (broad-flame) tips and keep them moving to avoid "hot spots". Check bore temperature with a temperature reading device frequently to avoid overheating.

2.3.4 Slide the heated drum hub or spider onto the shaft. Hold in position and allow them to cool. It is helpful to put a mechanical stop device onto the component face to prevent "over-shooting" the proper axial location if there is no physical stop on the shaft such as a machined shoulder.

Table 1
Fastener Description and Assembly Torque - ft.-lb. (Nm)

Description	Specification	SW51TLC1600	SW60TLC1600	SW66TLC1600	SW76TLC1600	SW76TLC2000
ELEM/SPDR/RIM	Size	7/8-9NC-2	1-8NC-2	1 1/4-7NC-2	1 1/4-7NC-2	1 1/4-7NC-2
	Quantity	32	36	40	48	48
	Torque, Dry	125 (169) "L"	190 (258) "L"	380 (515) "L"	380 (515) "L"	380 (515) "L"
DRUM/HUB	Size	1-8NC-2	1 1/2-6NC-2	1 1/2-6NC-2	1 1/2-6NC-2	1 1/2-6NC-2
	Quantity	20	20	30	42	42
	Torque, Lubed	510 (691) "L"	650 (881) "L"	650 (881) "L"	650 (881) "L"	650 (881) "L"
SPDR to LCKG Assy.	Size	3/4-10NC-2	3/4-10NC-2	1 1/2-6NC-2	1 1/2-6NC-2	1 1/2-6NC-2
	Quantity	2	2	2	4	4
	Torque, Lubed	130 (176) "LO"	130 (176) "LO"	325 (441) "LO"	325 (441) "LO"	325 (441) "LO"
HUB to LCKG Assy.	Size	1-8NC-2	1-8NC-2	1-8NC-2	1-8NC-2	1-8NC-2
	Quantity	2	2	2	2	2
	Torque, Lubed	190 (258) "LO"	190 (258) "LO"	190 (258) "LO"	190 (258) "LO"	190 (258) "LO"

Torque Limiting Coupling

2.4 Shaft alignment

Parallel Alignment Tolerance (Offset): Not to exceed 0.010 inch (0.254 mm) Total Indicator Reading (0.005 inch (0.127 mm) maximum off- set).

Angular Alignment Tolerance (Gap): Not to exceed 0.0005 inch per inch (0.0005 mm/ mm) diameter at which readings are taken ("D" on Figure 6 and 7).

Note: The alignment procedure described below has been used successfully on many grinding mills using an Airflex TLC or clutch application(s). Other procedures, of course, may be used; however, the alignment tolerances are the same regardless of the technique used.

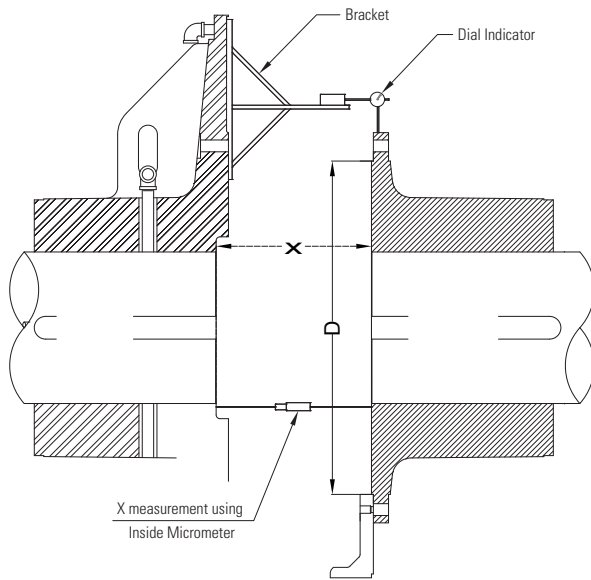

Figure 6

Angular alignment

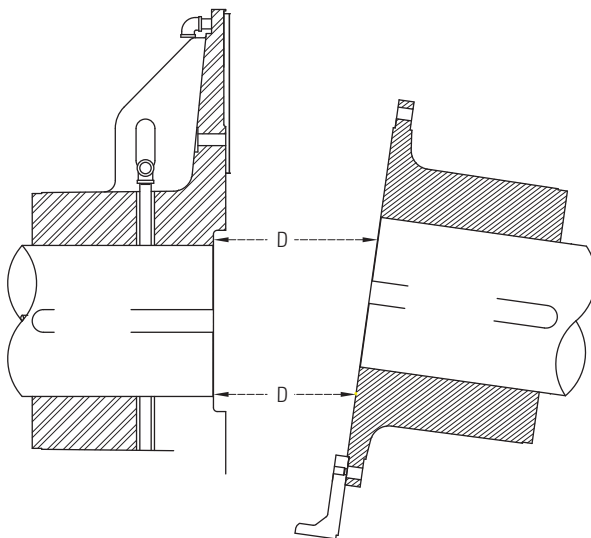

Figure 7

- 2.4.1 Foundations must be set so distance "X", shown on Figure 6 (or the appropriate drawing for non standard applications), is established. If the TLC is mounted on a shaft having plain bearings, make sure the shaft is centered within the bearings when establishing the "X" dimension. Refer to Table 2 for appropriate "X" dimensions.

Note: It is presumed that one of the shafts has been properly located and anchored. When setting and aligning the grinding mill drive components, always work from the pinion back to the motor.

- 2.4.2 Fabricate a rigid bracket for supporting a dial indicator and attach to the spider. See Figure 6.
- 2.4.3 Thoroughly clean the flange O.D. and the face of the drum hub where alignment readings are to be taken.
- 2.4.4 Rotate the spider and take parallel alignment readings off the drum hub flange O.D. If both shafts can be rotated together, the alignment readings are less influenced by any surface irregularities.

Note: On reverse-mounted TLC's where only one shaft can be rotated, the indicator is attached to the drum hub and readings are taken off of the spider O.D.



Caution

When recording parallel alignment readings, "sag" of the indicator/indicator bracket must be accounted for.

Table 2
X Dimensions

Size	"X" In. (mm)
51TLC1600	18.875 (479.4)
60TLC1600	18.750 (476.25)
66TLC1600	20.500 (520.7)
76TLC1600	18.87 (479.3)
76TLC2000	22.87 (580.9)

- 2.4.5 Angular alignment readings can be made by accurately measuring the gap between the spider and drum hub faces with an inside micrometer. If a dial indicator is used, make sure to monitor and correct for any axial movement of the shaft. To reduce the influence any surface irregularities may have on the angular alignment readings, index the spider 90 degrees after taking the initial set of readings. Take an additional set of readings and index the spider an other 90 degrees. Continue in this manner until four sets of readings have been taken For misalignment correction, use the average of the four readings at each position.

Torque Limiting Coupling

- 2.4.6 Shim and shift the base of the movable shaft to correct the misalignment. After tightening the base, recheck the alignment and correct if necessary. Make sure to check for a "soft foot" condition. Dowel or chock into position after satisfactory alignment has been achieved.

Note: On some applications, thermal growth of the mill or gear reducer (if present) may result in unacceptable shaft alignment in a running condition. It is always a good practice to make a "hot alignment" check and the shim if necessary.

2.5 Axial locking device adjustment

- 2.5.1 If the "X" dimension shown on Table 2 could not be achieved within +/- 0.250 inch (6.4mm), the axial locking device has a provision to accommodate this variation.
- 2.5.2 Position the motor shaft on its magnetic center and measure the gap between the faces of the drum hub and spider ("X" dimension on Table 2). The difference between this measured dimension and the value shown on Table 2 is the amount of correction to be made with adjustment of the axial locking device.
- 2.5.3 Referring to Figure 8, the overall length of the axial locking device can be adjusted by relocating shims (11 / 17) from one side of a bearing to another.
- 2.5.3.1 Remove four hex head screws and lock washers (6,7) from the bearing housing (8) and adapter plate (1 or 9).
- 2.5.3.2 Remove the snap ring (2) from the bearing housing.
- 2.5.3.3 After ensuring the shaft (3) is clean and free of foreign matter, nicks or burrs in the area between the two bearing housings, slide the bearing housing assembly toward the opposite bearing housing assembly to expose the bearing/spacer assembly (10,11,17).
- 2.5.3.4 Remove the bearing locknut and lockwasher (13,14) from the shaft.
- 2.5.3.5 The assembled length of the axial locking device is established by the location of the bearings with respect to the shaft. The assembled length can therefore be adjusted by moving spacers from one side of the bearing to the other. Two thicknesses of spacers are included in each assembly 0.025 inch (0.6 mm) and 0.098 inch (2.5 mm). After making the appropriate assembled length adjustment, reassemble, making sure the thinner spacers are against the bearing.

Note: After axial length adjustment (if any) spacers (17) must always be installed in contact with bearing (10) inner race, and must never be allowed to be in shaft (3) groove at bearing lockwasher (14) location after final tightening of bearing locknut (13)

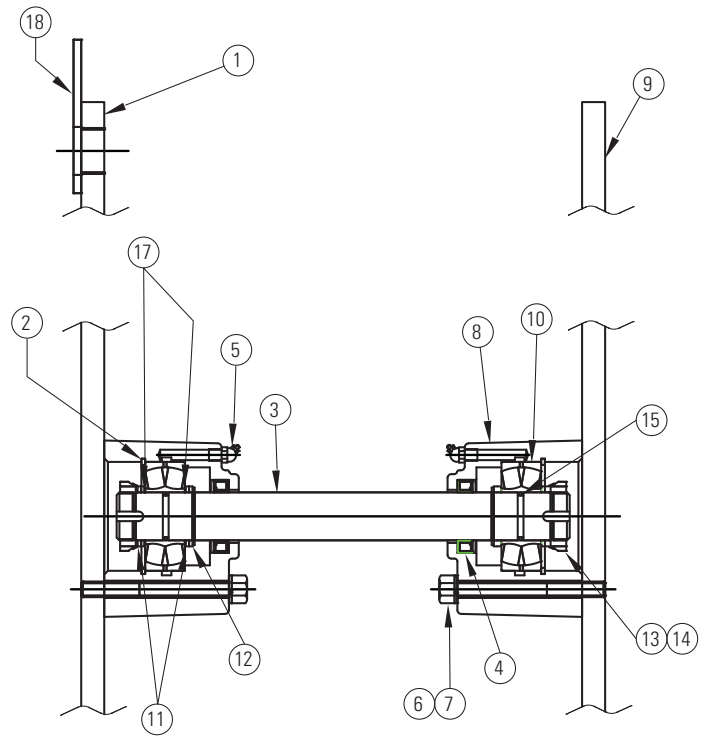

Figure 8

Item description axial locking assembly

Item	Description
1	Spider adapter plate
2	Internal snap ring
3	Shaft
4	Grease seal
5	Grease fitting
6	Hex head screw
7	Lockwasher
8	Bearing housing
9	Drum adapter plate
10	Bearing
11	Spacer
12	External snap ring
13	Bearing locknut
14	Bearing lockwasher
15	"O" Ring
17	Spacer
18	Spacer (Wired to spider adapter plate)

Torque Limiting Coupling

- 2.5.3.6 Tighten the locknut sufficiently to take up all axial clearance in the bearing/spacer/snap ring assembly.
- 2.5.3.7 Slide the housing back over the bearing and install the snap ring.
- 2.5.3.8 Secure and tighten the bearing housing to the adapter plate using four hex head screws and lockwashers. Tighten the screws to 35 ft.-lbs. (47 Nm).
- 2.5.3.9 After completing assembly, lubricate both bearings with No. 2 EP grease.

2.6 Installation of element and drum

- 2.6.1 Note the orientation of the drum flange with respect to the air connection(s) on the element and slide the drum into the element.
- 2.6.2 Attach the axial locking device to the drum flange with the appropriate screws and lockwashers. There are tapped holes in the drum flange to accept the screws.
- 2.6.3 Separate the (motor and pinion) shafts as far as the bearing clearances will allow and hoist the element drum (axial locking device) into position. Take special care when hoisting the element between the shafts. The axial locking device mounting plate can easily bind against the spider face.
- 2.6.4 Attach the drum to the drum hub with the appropriate fasteners. See Table 1. Make sure the bore in the drum flange fully engages the pilot on the drum hub.
- 2.6.5 Install the air connection gaskets onto the air tubes. The metal backup washer is to be positioned toward the elbow (away from the spider). See Figure 9.

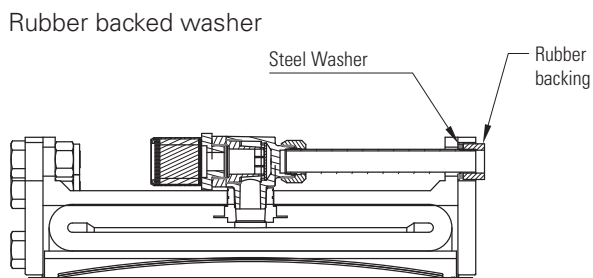

Figure 9

- 2.6.6 Align the element air connections with the passages in the spider and attach the element to the spider with the appropriate fasteners. See Table 1. Make sure the element fully engages the register in the spider.

- 2.6.7 Rotate the motor shaft and push the spider towards the mill until the axial locking device mounting plate is flush against the spider face and the motor is on magnetic center. Attach the axial locking device mounting plate to the spider with the appropriate screws and lock washers. Tighten the screws.



Caution

Do not attempt to pull the motor shaft back onto magnetic center by tightening the axial locking device mounting screws. To do so will damage the axial locking device.

2.7 Air control system

- 2.7.1 The typical TLC air control system(s) operating characteristics vary from one grinding mill to another, following are some general guidelines for installing the air controls.
 - 2.7.1.1 The air receiver tank(s) must be located as close to the TLC as possible (the tank should be located within 15 feet of the solenoid valve, and solenoid valve should be within five feet from the rotor seal) for consistent TLC response.
 - 2.7.1.2 Use full size piping and valves consistent with the rotor seal size and keep the number of elbows to a minimum.
 - 2.7.1.3 Use poppet-type solenoid valves. Spool valves should not be used.
 - 2.7.1.4 An air line lubricator is not required for the TLC element; however, if one is used, it must be a nonadjustable, mist-type.
 - 2.7.1.5 Make sure the flow control valve is installed with free flow (indicated by an arrow on the valve body) away from the TLC (free flow to exhaust).
 - 2.7.1.6 The final connection to the rotor seal MUST be made with flexible hose and place no radial load upon the rotor seal. Also, if the rotor seal is mounted onto the end of a motor shaft, an insulating coupling must be installed between the piping and the rotor seal.



Caution

Do not use rigid pipe at the connection to the rotor seal. Rigid piping will result in excessive loads on the rotor seal bearings, shortening life.

2.8 Electrical controls

- 2.8.1 The basic Airflex grinding mill TLC control provides for engagement of the TLC when the motor is not running and the mill is not turning. It also monitors the TLC for slippage during operation and disengages the TLC if slippage beyond the allowable user set limits should occur. Refer to the CP3130 TLC Slip control IOM for details.

Torque Limiting Coupling

3.0 Operation



Warning

Exceeding the operating limits described in this section may result in personal injury or equipment damage.

3.1 Torque, RPM and Pressure Limits

3.1.1 The developed torque is directly proportional to the applied air pressure. If the developed torque seems inadequate, check for oil, grease or dust contamination of the TLC elements or other drive train conditions that are causing an overload condition to occur.



Caution

Maximum applied air pressure is 125 psig (8.5 bar). Operation at pressures exceeding 150 psi may cause element damage.



Caution

The special (non-asbestos) friction material used in Airflex TLC units may not develop rated torque initially, if required a very short "wear-in" procedure may be required. (See the procedure note.)

3.1.2 Maximum safe operating speeds are shown on Table 3.



Danger

Do not exceed the operating speeds shown on Table 3. Operation at speeds greater than allowable will result in permanent damage to the TLC element, personal injury or death.

Table 3
Maximum safe operating speeds

Size	Maximum RPM
51TLC1600	550
60TLC1600	520
66TLC1600	480
76TLC1600	275
76TLC2000	275

3.2 Control component adjustment

3.2.1 Set the pressure switch (5) located on the air receiver tank to open at 60 psig (6.1 bar) falling. Use normally open contacts and wire in series with the solenoid valve coil. This is to prevent TLC engagement if operating pressure is below 60 psig or the specified application pressure setting.

3.2.2 Set the pressure switch (13) located in the air supply line to the TLC to close at a predetermined minimum pressure. Use normally closed contacts and wire into the motor starter interlock circuit. The purpose of this pressure switch is to prevent starting the motor with the TLC disengaged.

3.2.3 Set the pressure regulator to the specified minimum pressure for the application. This is the nominal air pressure required for operation of the TLC to start the mill.

3.2.4 Check all other interlocks that affect the starting of the mill and remove any jumpers that may have been installed.

4.0 Maintenance



Warning

Only qualified personnel should maintain and repair these units. Faulty workmanship may result in personal injury or equipment damage.



Caution

When replacing TLC components, use only genuine, Airflex replacement parts. Use of replacement material which is not of Airflex origin will void all warranties.

4.1 Periodic inspection

4.1.1 The following items may be inspected without disassembly of the TLC.

4.1.1.1 Friction shoe assembly lining wear - Check the lining thickness and compare to the values shown on Table 4.

Note: If the linings have worn to minimum allowable thickness or less, the friction shoe assemblies must be replaced as a complete set.

Table 4
Friction material thickness

Element size	Min. allowable lining thickness, inch (mm)	Original lining thickness, inch (mm)
51TLC1600	.470 (22,9)	.687 (17,4)
60TLC1600	.445 (11,3)	.687 (17,4)
66TLC1600	.531 (13,5)	.750 (19,1)
76TLC1600	.522 (13,3)	.750 (19,1)
76TLC2000	.519 (13,2)	.750 (19,1)

4.1.1.2 Contamination of shoes or drum oil, water or grease contamination will reduce the developed torque of the TLC. If this occurs the replacement of the friction shoe assemblies will be required.

Note: In extremely dusty environments, dust may accumulate in the backing plate cavities to the point where the friction shoes will not properly retract. Dust accumulations may be vacuumed out of the element cavities.

Torque Limiting Coupling



Caution

Do not attempt to use a solvent to remove oil or grease from the drum surface without first removing the TLC element.



Caution

Do not use compressed air to blow dust accumulations out of the backing plates. Although the friction material does not contain asbestos, the dust from the operating environment, may irritate the respiratory system.

- 4.1.1.3 Air control components - Check for proper adjustment of the air control components. Make sure the safety pressure switches are set correctly and are functioning properly. Repair any air leaks as discovered.
- 4.1.2 Partial or complete disassembly is required to inspect the following items.
 - 4.1.2.1 Drum diameter wear - Check the O.D. of the drum and compare to the values shown on Table 5. Minor heat-checking may be removed by machining the drum O.D. If the drum has been subjected to excessive heat, the open end may flare out, giving the impression that the drum has not worn. It is therefore important to check the diameter at several locations across the face.



Caution

Operation of the TLC element on a drum that is worn, or has been machined to less than minimum allowable diameter will result in damage to the element components.

- 4.1.2.2 Air actuating tube – Occasionally check that the actuating tube has not hardened or (aged) beyond a durometer reading in excess of 72 Shore A. Also if any portion of the tube is hardened in several areas over the recommended reading the tube must be replaced. Also check for any blisters or bubbles which would indicate ply separation. A tube in this condition must also be replaced.
- 4.1.2.4 Uneven friction lining wear - Tapered wear across the friction surface typically indicates a worn drum and/or misalignment. If two or more adjacent shoes are worn on one end only, the air actuating tube has most likely developed a ply separation at that location.

- 4.1.2.5 Backing plate wear - Wear on the ends of the backing plates from bearing against the side plates is indicative of misalignment or thrusting. If wear is on one end only, and uniform for all backing plates, a worn drum may be causing the shoes to thrust as the element engages. If wear exists on both ends of all of the backing plates, excessive misalignment is probably the cause. Slight notching in the torque bar cavity is normal; however, if the notching occurs in a short amount of time, check shaft alignment. If both walls in the torque bar cavity are notched, there may be a significant vibration (torsional) problem.

Note: The number preceding the letters “TLC” in the element size designates the original drum diameter in inches.

Example: 51TLC1200 - Original drum diameter = 51.00 inches (1295 mm).

Minimum allowable drum diameter is:
 51 inch (1295 mm) - 0.25 (6.35mm)=
 50.75 inch (1289.05 mm).

- 4.1.2.6 Release springs and torque bars - Excessive wear at the ends of the torque bars where the release springs make contact indicates excessive parallel misalignment.

Table 5
Drum wear limits

Element size	Max. allowable wear on drum diameter inch (mm)
51TLC1600	.25 (6,35)
60TLC1600	.25 (6,35)
66TLC1600	.25 (6,35)
76TLC1600	.25 (6,35)
76TLC2000	.25 (6,35)

- 4.1.2.7 Contamination of friction shoes – Friction linings which have become contaminated by oil or grease etc. must be replaced. Also, linings that might have been charred from excessive slipping must be replaced.



Caution

When using any solvent, always follow the appropriate safety precautions.

- 4.1.2.8 Excessive dust accumulation - If dust becomes packed in the backing plate cavities, a pressurized enclosure should be considered. Excessive accumulations will prevent complete shoe retraction.

Torque Limiting Coupling

4.2 Removal of element assembly and drum



Warning

Prior to removal of the TLC, make sure the mill is stopped and will remain in, a safe condition by following the required "lock-out-tag-out" or other site specific safety procedures.

- 4.2.1 Match mark the element to the spider and the drum to the drum hub.
- 4.2.2 Disconnect the element from the spider and allow it to rest on the drum.
- 4.2.3 Disconnect the axial locking device from the spider and separate the (motor and pinion) shafts as far as the bearings will allow.
- 4.2.4 Connect an inspected and approved overhead support that exceeds the required weight to be lifted to the element and apply enough tension to support the weight of the element and drum.
- 4.2.5 Remove the fasteners attaching the drum to the drum hub and hoist the element/drum out from between the shafts. Take special care when hoisting the element/drum from between the shafts, as the axial locking device mounting plate binds easily against the spider face.



Caution

Use extreme care when disconnecting the drum from the hub. Shear points exist at the mounting holes.

4.3 Removal of spider and drum hub

- 4.3.1 Removal is not necessary for routine TLC maintenance. Removal may only be needed if access is needed to the motor shaft, pinion shaft, or gearbox shaft where these components are located.
- 4.3.2 Puller holes are provided for removal if these must be removed. It will require heating of the spider and drum hub along with the pressure supplied by a properly located puller attached to the component to be removed. When heating, use torches with rosebud tips. Heat the component uniformly to prevent hot spots and do not exceed 275°F (135°C).

4.4 Disassembly of the element

- 4.4.1 Lay the element flat on a clean work surface.
- 4.4.2 Remove one of the side plates and inspect the surface that the friction shoes contact for any unusual wear patterns, especially look at the end scallops on the side plates and check for excessive wear.
- 4.4.3 Remove the friction shoe assemblies, torque bars and release springs. If the torque bars and springs come out of the element with the friction shoe assemblies, carefully tap them out of the backing plate cavities. Note any wear and replace in sets as necessary. See table X.



Caution

Whenever the element is removed and disassembled, it is always good practice to replace the release springs.

- 4.4.4 Remove the air connection QRV's and spiral snap rings which secure the air actuating tube to the rim. Carefully remove the air actuating tube from the rim and thoroughly inspect. Replace if necessary. See Figure 10.

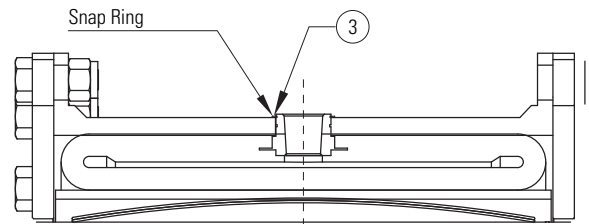

Figure 10

- 4.4.5 Remove the remaining side plate only if it is to be replaced.

4.5 Friction shoe assembly replacement



Caution

Use only genuine Airflex replacement parts. Use of replacement parts not of Airflex origin will void all warranties.

- 4.5.1 Make sure the torque bars and release springs have been removed from the backing plates.

Torque Limiting Coupling

4.6 Assembly of the element

- 4.6.1 Make sure all of the components have been cleaned and any damaged or worn components have been repaired or replaced.
- 4.6.2 Assemble one of the side plates to the rim with cap screws and lockwashers. It is not necessary to install through bolts and locknuts at this time.
- 4.6.3 Lay the rim/side plate assembly on a clean, flat work surface, side plate down.
- 4.6.4 Carefully insert the air actuating tube into the rim. Push the valves on the tube through the corresponding holes in the rim and install the spiral snap rings (if applicable). See Figure 11.

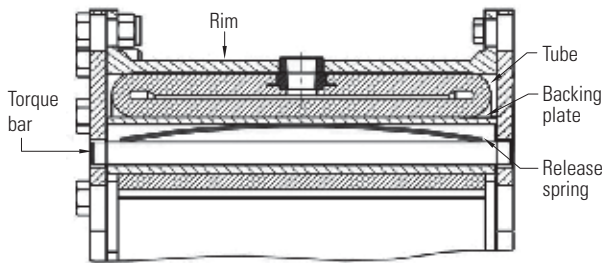

Figure 11

- 4.6.5 Place a torque bar in each mating hole in the side plate, slide a friction shoe assembly onto each torque bar and carefully tap a release spring (51TLC1600, 60TLC1600, 66TLC1600 and 76TLC1600 elements have two release springs in each cavity) (the 76TLC2000 has only one release spring per shoe) into place. Make sure the spring(s) is positioned on the side of the torque bar opposite the friction lining. Also, the spring must contact the torque bar at two points, not one. See Figure 11.
- 4.6.6 Lay the remaining side plate in position so the air connections and torque bar holes are properly aligned.
- 4.6.7 Carefully guide the torque bars into the corresponding holes in the side plate. It is often helpful to install four equally spaced screws and nuts through the rim and side plate to keep some tension on the side plate throughout this step.
- 4.6.8 Attach the side plate to the rim with cap screws and lockwashers, making sure all of the torque bars are seated in their side plate holes.

- 4.6.9 Note the orientation of the air connections and install the through bolts and locknuts where applicable.
- 4.6.10 Re-install the elbows using a good quality sealant on the pipe threads. Install the air connections on the element. Install the short air connections.
- 4.6.11 Re-install per 2.0.

5.0 Spare parts storage

5.1 Element assemblies

- 5.1.1 Element assemblies must always be stored flat. Storage in the standing position may cause the rims to go out-of-round.

5.2 Drums

- 5.2.1 Drums must be stored open end down. Similar to element assemblies, storage of a drum in the standing position will adversely affect roundness.

5.3 Air actuating tubes

- 5.3.1 Air actuating tubes are shipped from the Airflex plant folded to conserve shipping space. Upon receipt, remove the tube from its container and allow it to assume its natural shape. Store tube(s) in a cool, dry area, away from electrical equipment and ultraviolet light.

6.0 Ordering information/technical assistance

6.1 Equipment reference

- 6.1.1 In any correspondence regarding Eaton Airflex Equipment, refer to the information on the product nameplate LA-Drawing number, or bill of material and call or write.

Eaton
Hydraulics Group USA
Airflex Products
9919 Clinton Rd.
Cleveland, Ohio
44144
Tel: (216) 281-2211
Fax: (216) 281-3890
www.eaton.com/hydraulics

Torque Limiting Coupling

7.1 Parts breakdown of TLC element assemblies (Single wide element assemblies) figures 1 and 10.

Model		51TLC1600		60TLC1600		66TLC1600		76TLC1600		76TLC2000	
Sub-assembly element part number		146582HH		146583HH		146584HH		146585HH		146586HH	
Item	Description	Part number	Quantity	Part number	Quantity	Part number	Quantity	Part number	Quantity	Part number	Quantity
1	Rim	506674	1	510629	1	509548	1	515144	1	515377	1
2	Tube	505580	1	511348	1	511350	1	515142	1	515375	1
3	Snap rings	000190X0083	4	000190X0015	4	000190X0015	4	000190X0015	4	000190X0015	4
4	QRV	146506BE	4	146506BE	4	146506BE	4	146506BE	4	146506BE	4
5	Air tube	417178-09	4	412178-18	4	412178-04	4	412178-04	4	412178-04	4
6	Rubber washer	412324-08	4	412324-09	4	412324-09	4	412324-09	4	412324-09	4
7	Friction shoe assembly	515759	18	515762	20	515811	22	515815	25	515808	25
8	Side plate	417477	2	417507	2	417479	2	515816	2	515816	2
9	Torque bar	308647	18	308648	20	308648	22	308649	25	308650	25
10	Release spring	304215	36	304215	40	304215	44	304215	50	308577	25

8.1 Parts breakdown of TLC hub, spider, drum, axial locking assy. and rotorseal (Single wide element assemblies) figure 2

Model		51TLC1600		60TLC1600		66TLC1600		76TLC1600		76TLC2000	
Item	Description	Part number	Quantity	Part number	Quantity	Part number	Quantity	Part number	Quantity	Part number	Quantity
11	Hub	416222	1	415312	1	417517	1	515147	1	515147	1
12	Spider	513886	1	510807	1	514849	1	515152	1	515152	1
13	Drum	409711	1	411501	1	413727	1	515149	1	515382	1
14	Axial locking assembly	145839DD	1	145839DU	1	145839DW	1	145839EJ	1	145839EL	1
15	Rotorseal	105519AA	1	105519AA	1	105519AA	1	105519AA	1	105519AA	1

Torque Limiting Coupling

9.1 (Standard) Torque bar kit

Model	Kit P/N	Description	Torque bar (9)
51TLC1600	146500AU	Part no.	308647
		Quantity	18
60TLC1600	146500DA	Part no.	308648
		Quantity	20
66TLC1600	146500DB	Part no.	308648
		Quantity	22
76TLC1600	146500DC	Part no.	308649
		Quantity	25
76TLC2000	146500DD	Part no.	308650
		Quantity	25

9.2 (Standard) Friction shoe assembly, torque bar and release spring kit

Model	Kit P/N	Description	FSA (7)	Release Spring (10)	Torque bar (9)
51TLC1600	146237U	Part no.	515759	304215	308647
		Quantity	18	36	18
60TLC1600	146237V	Part no.	515762	304215	308648
		Quantity	20	40	20
66TLC1600	146237X	Part no.	515811	304215	308648
		Quantity	22	44	22
76TLC1600	146237Y	Part no.	515815	304215	308649
		Quantity	25	50	25
76TLC2000	146237Z	Part no.	515808	308577	308650
		Quantity	25	25	25

10.1 Description axial locking assembly

Model		51TLC1600		60TLC1600		66TLC1600		76TLC1600		76TLC2000	
Axial locking assembly number		145839DD		145839DU		145839DW		145839EJ		145839EL	
Item	Description	Part number	Quantity	Part number	Quantity	Part number	Quantity	Part number	Quantity	Part number	Quantity
1	Spider adapter plate	414724-02	1	414724-08	1	414724-10	1	414724-10	1	414724-10	1
2	Internal snap ring	000138X0028	2	000138X0028	2	000138X0028	2	000138X0028	2	000138X0028	2
3	Shaft	414726-04	1	414726-13	1	414726-15	1	414726-15	1	414726-18	1
4	Grease seal	000113X0451	2	000113X0451	2	000113X0451	2	000113X0451	2	000113X0451	2
5	Grease fitting	000145X0003	2	000145X0003	2	000145X0003	2	000145X0003	2	000145X0003	2
6	Hex head screw	000001X0421	8	000001X0421	8	000001X0421	8	000001X0421	8	000001X0421	8
7	Lockwasher	000068X0014	8	000068X0014	8	000068X0014	8	000068X0014	8	000068X0014	8
8	Bearing housing	414256	2	414256	2	414256	2	414256	2	414256	2
9	Drum adapter plate	414725-04	1	414725-11	1	414725-13	1	414725-15	1	414725-15	1
10	Bearing	000136X0123	2	000136X0123	2	000136X0123	2	000136X0123	2	000136X0123	2
11	Spacer	000153X0874	8	000153X0874	8	000153X0874	8	000153X0874	8	000153X0874	8
12	External snap ring	000139X0037	2	000139X0037	2	000139X0037	2	000139X0037	2	000139X0037	2
13	Bearing locknut	000114X0007	2	000114X0007	2	000114X0007	2	000114X0007	2	000114X0007	2
14	Bearing lockwasher	000115X0007	2	000115X0007	2	000115X0007	2	000115X0007	2	000115X0007	2
15	"O" Ring	000073X0051	2	000073X0051	2	000073X0051	2	000073X0051	2	000073X0051	2
17	Spacer	000153X0951	16	000153X0951	16	000153X0951	16	000153X0951	16	000153X0951	16
18	Spacer (Wired to spider adaptor plate)					306987	2	306987	2	306987	2

Eaton
Hydraulics Group USA
Airflex Products
9919 Clinton Road
Cleveland, Ohio 44144
USA
Tel: 216-281-2211
Fax: 216-281-3890
www.eaton.com/airflex

Eaton
Eaton Hydraulics Group China
Airflex Products
281 Fa Sai Road
WaiGaoQiao Free Trade Zone
Shanghai 200131
China
Tel: (+86 21) 5048 4811
Fax: (+86 21) 5048 4911