

# Installation, operation and maintenance of Airflex Quick Release Valve



# Table of Contents

Section	Description	Page No.
	<b>AIRFLEX® QUICK RELEASE VALVE</b>	3
<b>1.0</b>	<b>INTRODUCTION</b>	4
1.1	Description	4
1.2	How It Works	4
1.3	Specifications	5
<b>2.0</b>	<b>INSTALLATION</b>	5
2.1	Air piping	5
2.2	Mounting	6
2.3	Testing	6
<b>3.0</b>	<b>MAINTENANCE</b>	7
3.1	Valve and diaphragm service	7
3.2	Testing	8
<b>4.0</b>	<b>ORDERING INFORMATION/TECHNICAL ASSISTANCE</b>	8
4.1	Equipment reference	8
<b>5.0</b>	<b>REVISION PAGE</b>	8



## WARNING

**Forward this manual to the person responsible for Installation, Operation and Maintenance of the product described herein. Without access to this information, faulty Installation, Operation or Maintenance may result in personal injury or equipment damage.**



## CAUTION

Use Only Genuine Airflex® Replacement Parts. The Airflex Division of Eaton Corporation recommends the use of genuine Airflex replacement parts. The use of non-genuine Airflex replacement parts could result in substandard product performance, and may void your Eaton warranty. For optimum performance, contact Airflex:

In the U.S.A. and Canada: **(800) 233-5926**  
Outside the U.S.A. & Canada: **(216) 281-2211**  
Internet: **www.airflex.com**

**Note:** This manual pertains to the AIRFLEX DIAPHRAGM OPERATED QUICK RELEASE VALVE which is identified by its silver housing. If your valve housing is anodized green, service it according to manual QRV 9090 or replace the entire valve with the diaphragm style.

## AIRFLEX® Quick release valve

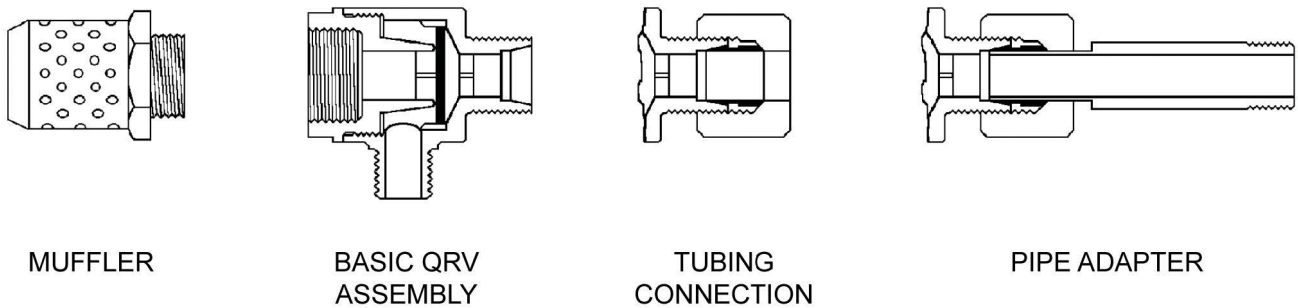

Figure 1. Quick release valve

TABLE 1: QRV Model and kit numbers

QRV sizes →	3/8	1/2	3/4	1"
Basic number →	145406	145407	145141	146506
QRV Config. Options and kits	Suffix designation (Eg. 145406DE)			
w/Metal sleeve	DE	DE	DE	BD
w/Rubber sleeve	DF	DF	DF	-
w/Inlet pipe thread	DG	DG	DG	-
w/Metal sleeve & Muffler**	DS	DS	DS	BE
w/Rubber sleeve & Muffler**	DR	DR	DR	-
w/Inlet pipe thread & Muffler**	DT	DT	DT	-
w/Metal sleeve & pipe adapter	DL	DL	DL	BR
w/Metal sleeve, Pipe adapter & Muffler	-	-	-	CA
w/Metal sleeve & 1/4 pipe adapter*	DM	DM	DM	-
Diaphragm & End cap kit***	DP	DP	DP	DP
Muffler kit***	145407DQ			DQ

The option and kit designation letters must be added as a suffix to the basic model number to completely identify the QRV model or kit.

\* 1/4 NPT adapter for 3/8 QRV only.

\*\* Mufflers are not factory-assembled to QRV. See Installation section.

\*\*\* Diaphragm and end cap kit contains a diaphragm, end cap and sealant. Muffler kit contains muffler and sealant.

## 1.0 Introduction

Throughout this manual there are a number of HAZARD WARNINGS that must be read and adhered to in order to prevent possible personal injury and/or damage to equipment. Three signal words "DANGER", "WARNING" and "CAUTION" are used to indicate the severity of a hazard, and are preceded by the safety alert symbol.

---

**⚠ DANGER**

---

**Denotes the most serious hazard, and is used when serious injury or death WILL result from misuse or failure to follow specific instructions.**

---

**⚠ WARNING**

---

**Used when serious injury or death MAY result from misuse or failure to follow specific instructions.**

---

**⚠ CAUTION**

---

**Used when injury or product/equipment damage may result from misuse or failure to follow specific instructions.**

It is the responsibility and duty of all personnel involved in the installation, operation and maintenance of the equipment on which this device is used to fully understand the:

---

**⚠ DANGER**

---



---

**⚠ WARNING**

---



---

**⚠ CAUTION**

---

**procedures by which hazards can be avoided.**

## 1.1 Description

The Airflex® QRV is a quick release valve that facilitates the release of air from a pressurized chamber i.e., air cylinders, clutches, brakes or other pneumatic devices. In essence it provides an exhaust port at the chamber rather than exhausting through long supply lines and control components. The function they perform is especially important in high speed cycling equipment. They prevent sluggish operation, overlap and excessive wear. Their importance in an air control system cannot be overemphasized.

QRV's are available in four sizes for direct connection to 3/8, 1/2, 3/4 and 1 inch pipe. Models are also available which permit 1/2, 5/8 and 3/4 inch outside diameter tubing connections to the QRV inlet port.

Exhaust noise from the valve can be reduced by using a muffler, which threads into the tapped hole in the end cap.

## 1.2 How it works

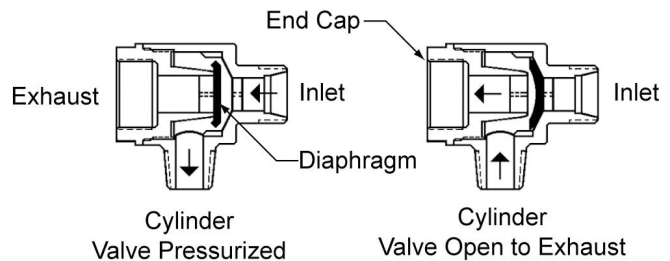

**Figure 2.**

The Airflex QRV contains a diaphragm designed to function on a pressure differential. Air pressure at the valve inlet seats the diaphragm on the end cap, closing the exhaust port. Applied pressure, acting on the outer unsupported diaphragm area, deflects it and allows air to flow to the cylinder port. See Figure 2.

When a pressure drop occurs in the air supply, the pressure differential lifts the diaphragm from the exhaust port and seats it on the inlet port. Air from the pressurized device can now flow freely to atmosphere through the valve's exhaust port.

If the cylinder pressure falls below the inlet pressure, the pressure differential on the diaphragm will close the exhaust port, preventing further exhaust.

### 1.3 Specifications

**Table 2: Port sizes**

QRV Size	Inlet	Cylinder
3/8	3/8 NPT or 1/2 OD Tube	3/8 NPT
1/2	1/2 NPT or 5/8 OD Tube	1/2 NPT
3/4	3/4 NPT or 3/4 OD Tube	3/4 NPT
1	1" OD Tube	1" NPT

**Table 3: Flow capacity in SCFM(m<sup>3</sup>/min)\***

QRV Size	Inlet	Cylinder to Exhaust
3/8	121 (3.4)	206 (5.8)
1/2	172 (4.9)	256 (7.2)
3/4	287 (8.1)	376 (17.2)
1	Contact factory	

\* At 100 PSIG (6.9 Bar) inlet pressure with full pressure drop.

**Maximum operating pressure:**

150 PSI (10.3 Bar)

**Minimum sealing pressure:**

2 PSI (.14 Bar)

**Air quality:** Clean and dry to avoid contamination of housing and diaphragm. Any additives used in the air supply must be compatible with valve materials.

**Operating temperature range:**

-40°F (-40°C) to 120°F (49°C)

**Mean life:** Over 5 million cycles 75 PSI (5.1 Bar) and 80°F (27°C).

**Diaphragm material:** Polyurethane

**Housing material:** Zinc alloy

**End cap material:** Noryl®

**Graphic symbols:**

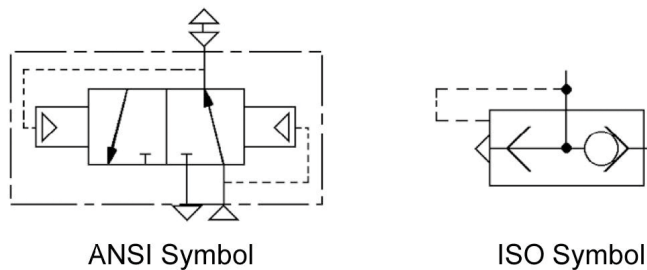

Figure 3.

## 2.0 Installation

**⚠ WARNING**

Before performing any work, read this manual and study all figures. Assure yourself that you understand and can do what is required in each step. Failure to follow these instructions may affect quick release valve operation and may result in exposure to personal injury.

**⚠ WARNING**

Before installing the valve, set and block the machine or equipment in a secure position; close the air shutoff valve and exhaust air from air lines; and disconnect all electrical power.

### 2.1 Air piping

2.1.1 For fastest response time, use an inlet pipe size equal to or larger than the quick release valve size. Minimize the length of pipe between the quick release valve and air control valve. Keep the number of fittings, bends and other restrictions in the inlet line to a minimum.

2.1.2 Piping should be free of foreign material such as pipe thread sealant, metal chips, etc. Pipe and tubing ends must be reamed after cutting to prevent a reduction of effective pipe or tube diameter.

**⚠ CAUTION**

Do not allow foreign matter to enter the quick release valve. Particles of foreign matter can prevent diaphragm sealing and cause air leakage.

2.1.3 Refer to 1.3 for air quality, additives and allowable operating pressures.

## 2.2 Mounting

2.2.1 Screw the cylinder port of the quick release valve into the female port of the device using a minimum of pipe thread sealant. Use a wide, flat faced wrench which will not crimp or damage the valve body. The quick release valve must be torqued enough to produce a tight seal, but not more than the value given in Table 4.

---

### WARNING

**Do not position the quick release valve exhaust port in the up position or allow foreign matter to enter the valve housing. Particles of foreign matter will enter the exhaust air stream and/or prevent diaphragm seating. Either condition could result in personal injury or damage to equipment.**

---

### WARNING

**Position the quick release valve exhaust port so that the exhaust air stream does not strike operating personnel. Particles of foreign matter picked up by the air stream can cause personal injury.**

---

### CAUTION

**Position the quick release valve exhaust port so that there are no restrictions to the exhaust air flow. Any restriction will slow down the valve response time.**

**Table 4: Maximum allowable tightening torque**

QRV Size	Torque
3/8	40 lb. ft. (54 Nm)
1/2	50 lb. ft. (67 Nm)
3/4	
1	

2.2.2 If the quick release valve has pipe threads on the inlet port, make a direct pipe connection. Do not exceed the tightening torques given in Table 4.

2.2.3 For quick release valves having tubing connections, slide the nut and sleeve onto the inlet air tubing and insert the tubing or pipe adapter into the valve housing until it bottoms. Slide the sleeve into its seat in the housing. Tighten the nut sufficiently to produce an air seal but not more than the value given in Table 4.

2.2.4 If a muffler is to be used, install per the following instructions.

---

### WARNING

**Loctite® must be used where called for in the following procedure. Mufflers installed without Loctite® may work loose during operation resulting in personal injury.**

**Note:** Quick release valves supplied prior to September, 1989 do not have threaded end caps to accept the muffler. The end caps on these valves must be replaced. Hence order both "Diaphragm & End Cap Kit" and "Muffler Kit" for maintenance. Refer to the Maintenance section in this manual for end cap replacement.

**Note:** Mufflers are not factory-assembled to the quick release valves due to possible interference with the rims of Airflex clutch elements.

2.2.4.1 *Thoroughly clean the female threads in the quick release valve end cap and the male threads on the muffler.*

2.2.4.2 *Apply Loctite® #222 (included in the kit) to the threads on the muffler, using one drop per thread, and screw the muffler into the end cap. Torque the muffler to 60 lb.-in. (7 Nm).*

## 2.3 Testing

2.3.1 Apply air pressure to the quick release valve. The valve and its connections should not leak under pressure. If the valve leaks, refer to the Maintenance section in this manual.

2.3.2 Cycle the valve several times to ensure proper operation. If the valve response time appears sluggish, check for restrictions in the air supply line.

### 3.0 Maintenance

**⚠ WARNING**

**Before performing any work, read this manual and study all figures. Assure yourself that you understand and can do what is required in each step. Failure to follow these instructions may affect quick release valve operation and may result in personal injury.**

Two quick release valve replacement kits are available for valve rebuilding. An end cap/diaphragm kit is available for valves not having mufflers, and contains an end cap, diaphragm and tube of Loctite® #222. In addition to this a muffler kit is available for muffler replacement only and it contains muffler and tube of Loctite® #222. It is advisable to stock at least one spare quick release valve for each size used in an installation.

The quick release valve should be periodically checked for proper functioning. If the valve fails to seal, it should be inspected internally. Usually foreign material will be found which has been carried through the piping. If a valve becomes ineffective after prolonged service, it can be restored to good operating condition by rebuilding.

#### 3.1 Valve and diaphragm service

**⚠ WARNING**

**Before performing any work on the valve, set and block the machine or equipment in a secure position; close the air shutoff valve and exhaust all air from the air lines; and disconnect all electrical power in order to prevent personal injury and/or equipment damage.**

- 3.1.1 If the quick release valve exhaust port is positioned downward, it will be difficult to service the diaphragm. It is recommended that the valve be removed from the equipment and bench-serviced.
- 3.1.2 Use a flat faced wrench to unscrew the muffler (if present) and the end cap. The diaphragm may fall out of the housing at this time. Discard the end cap, muffler and diaphragm.

**Note:** The end caps on quick release valves manufactured prior to September, 1989, have hexshaped exhaust ports to accommodate an allen wrench for end cap removal. Refer to Table 5 for the appropriate wrench size to remove the end cap. Discard after removal.

**Table 5: End cap allen wrench size**

QRV Size	Width across flats
3/8	1/2"
1/2	3/4"
3/4	
1	N/A

- 3.1.3 If the diaphragm did not fall out of the housing, gently pry along its outside diameter, being careful not to damage the sealing surface on the housing.
- 3.1.4 Inspect the diaphragm sealing surface in the housing (shown on figure) If the surface is worn, scratched or corroded, the entire quick release valve must be replaced.

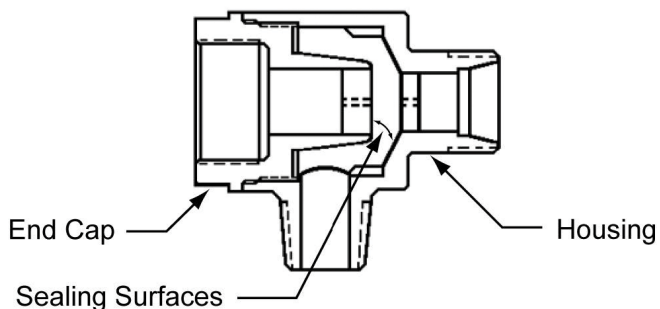

**Figure 4.**

**⚠ WARNING**

**Do not attempt to renew the diaphragm sealing surface by sanding or machining. Machining the surface will increase the diaphragm operating gap and cause the valve to malfunction.**

- 3.1.5 Thoroughly clean the inside of the housing and the internal threads in the housing.

**⚠ CAUTION**

**Do not allow foreign matter to enter either the valve housing or muffler. Particles of foreign matter can prevent diaphragm sealing.**

- 3.1.6 Insert a new diaphragm into the housing so it bottoms against the inlet port.

**⚠ WARNING**

**Loctite® must be used where called for in the following procedure. An end cap and/or muffler installed without Loctite® may work loose during operation resulting in personal injury or equipment damage.**

3.1.7 Remove and discard the protective cap from the replacement end cap. Apply Loctite® #222 to the threads of the end cap, using one drop per thread, and screw the end cap into the housing. Make sure the diaphragm is located properly in the housing. Torque the end cap to 60 lb-in. (7Nm).

3.1.8 If there is sufficient swing clearance on the equipment, the muffler (if applicable) may be installed at this time; otherwise, install the quick release valve and muffler onto the equipment per the Installation section of this manual. When installing the muffler, do not forget to use Loctite® #222 on the muffler threads and torque to 60 lb-in. (7Nm).

### 3.2 Testing

3.2.1 Test by applying air pressure to the valve. The valve should not leak under pressure. Removing the air pressure should cause the diaphragm to shift and allow the air to exhaust through the end cap and muffler. If the valve does not function properly, repeat the servicing procedure.

## 4.0 Ordering information/technical assistance

4.1 In any correspondence regarding Airflex quick release valves, always refer to the size and port configuration and call or write:

Eaton Corporation  
Airflex Division  
9919 Clinton Road  
Cleveland, Ohio 44144  
Tel.: (216) 281-2211  
Fax: (216) 281-3890  
Internet: www.airflex.eaton.com

Loctite is a registered trademark of Henkle Technologies.  
Noryl is a registered trademark of The General Electric Company.

## 5.0 Revisions

Original publication date: October 1987

Revision date	Change	Page
November, 2006	-	-
April, 2018	Recreated Table 1 QRV Model and kit numbers with new information	3
	Added two new notes "The option and kit designation letters..." and "**** Diaphragm and end cap kit contains..."	3
	Added new text "Quick release valves supplied prior to September, 1989"	6
	Deleted information from note "Mufflers are not factory-assembled to the quick release valves..."	6
	Added new text paragraph "Two quick release valve replacement kits are available..."	7
October, 2018	Updated TABLE 1: QRV Model and kit numbers	3

**Eaton**  
Hydraulics Group USA  
Airflex Division  
9919 Clinton Road  
Cleveland, OH 44144-1077  
Tel: 216-281-2211  
Fax: 216-281-3890

**Eaton**  
Hydraulics Group Asia Pacific  
Airflex Division  
281 Fa Sai Road  
Waigaoqiao Free Trade Zone  
Shanghai 200131  
China  
Tel: (+8621) 5048-4811  
Fax: (+8621) 5048-4911