

Installation, Operation and Maintenance Manual



Powering Business Worldwide

CP3110 Grinding Mill Slip Detection Control



WARNING

This equipment should be installed, adjusted, and serviced by qualified electrical personnel familiar with the construction and operation of this type of equipment and the hazards involved. Failure to observe this precaution could result in death or severe injury.

Read this manual thoroughly and make sure you understand the procedures before you attempt to operate this equipment. The purpose of this manual is to provide you with information necessary to safely operate, maintain, and troubleshoot this equipment. Keep this manual for future reference. Forward this manual to the person responsible for Installation, Operation and Maintenance of the product described herein. Without access to this information, faulty Installation, Operation or Maintenance may result in personal injury or equipment damage.

Note: This manual is to be used for Eaton Airflex control panel part number 209825-103 (used with VC clutch applications) and 209825-109 (used with VC and HEVC clutch applications) only as it includes information that is unique to that control configuration. For information relevant to other slip detection control panels supplied by Eaton, please contact the factory to assist you in identifying the appropriate manual.



CAUTION

Use Only Genuine Airflex® Replacement Parts Eaton's Airflex division recommends the use of genuine Airflex replacement parts. The use of non-genuine Airflex replacement parts could result in substandard product performance, and may void your Eaton warranty.

For optimum performance, contact Airflex:

In the U.S.A. and Canada: (800) 233-5926
Outside the U.S.A. and Canada: (216) 281-2211
Internet: www.eaton.com/airflex

1. INTRODUCTION		
1.1	Description	4
1.2	Application	4
2. GENERAL OPERATION		
2.1	Start Up Monitoring	4
2.2	Monitors During Running Operation	4
2.3	System Description and Theory of Operation	4
3. INSTALLATION		
3.1	Factory Setup	5
3.2	Control Panel	6
3.3	Sensor Target Installation	6
3.4	Proximity Sensors	6
4. SPECIFIC OPERATION		
4.1	Mode Selection HMI Pushbuttons	8
4.2	General Operation	9
5. FAULT DESCRIPTION AND RESET PROCEDURES		
5.1	Indicating Lights	11
5.2	MILL RUNNING Light (Green)	11
5.3	Short Start Light (White)	11
5.4	Fault Light (Red)	11
5.5	Resetting a Fault	12
5.6	Operating Information	12
5.7	Resetting the Information in the PLC	12
5.8	Resetting the HMI	12
6. TROUBLESHOOTING		
6.1	Clutch	13
6.2	Control Panel	13
6.3	PLC	13
6.4	I/O	13
7. ORDERING INFORMATION/TECHNICAL ASSISTANCE		14
8. APPENDIX		14
9. REVISIONS		15

1.0 Introduction

Throughout this manual there are a number of HAZARD WARNINGS that must be read and adhered to in order to prevent possible personal injury and/or damage to equipment. Three signal words "DANGER", "WARNING" and "CAUTION" are used to indicate the severity of the hazard, and are preceded by the safety alert symbol..

DANGER

Denotes the most serious injury hazard, and is used when injury or product/equipment damage may result from misuse or failure to follow specific instructions.

WARNING

Used when serious injury or death MAY result from misuse or failure to follow specific instructions.

CAUTION

Denotes the most serious injury hazard, and is used when serious injury or death WILL result from misuse or failure to follow specific instructions.

Note: It is the responsibility and duty of all personnel involved in the installation, operation and maintenance of the equipment on which this device is used to fully understand

the  Danger  Warning  Caution procedures by which hazards are to be avoided.

1.1 Description

Eaton's clutch slip detection control provides protection for grinding mill drive systems and has been developed to prevent costly damage to the motor, clutch, or other grinding mill drivetrain components. This system continuously monitors clutch performance during start-up and running operations. This control will detect excessively fast starts, long starts, and clutch slippage during operations.

1.2 Application

Eaton's clutch slip detection control has been specifically designed to be used with Airflex VC and HEVC grinding mill clutches. However, this control can be effectively applied to other clutch applications. Contact your Eaton sales representative for further information.

2.0 General operation

2.1 Start up monitoring

2.1.1 During a mill start, the control monitors the time required to engage the clutch and bring the mill to full RPM (clutch lock-up). If the clutch locks up too quickly, a white warning light on the Human Machine Interface (HMI) will illuminate alerting the operator that an air flow adjustment is required to achieve optimum acceleration time. This condition, if not corrected, can eventually lead to drive train component damage.

2.1.2 If the clutch does not lock-up (full mill RPM not achieved) within a predetermined time frame, the control will abort the start (disengage the clutch). A red fault light will also illuminate to indicate the clutch was automatically disengaged because of excessive slippage.

2.1.3 Another start cannot be attempted until the control is physically reset at the mill. This prevents successive start attempts from a remote control room.

2.2 Monitors during running operation

2.2.1 While running, the RPM of the input and output shaft are continually compared. If for some reason the clutch begins to slip, the control will sense the difference in RPM and disengage the clutch, again illuminating a fault light and requiring the control to be physically reset.

2.2.2 An optional JOG and BYPASS feature is available with this control. In the JOG mode, the control protects the clutch as in the RUN mode, while the BYPASS feature does not protect the clutch.

2.3 System description and theory of operation

2.3.1 Slip is detected by the use of two proximity sensors. These sensors generate pulses as targets pass them. Typically there is one target on the drive side (spider), and one on the driven side (drum hub). By reading the elapsed time between pulses at both the input shaft proximity sensor and the output shaft proximity sensor, the control decides when an abnormal condition is occurring. A long start condition is detected if the output shaft time does not match the input shaft time within the allowable maximum start time. A short start condition is detected if the output shaft time matches the input shaft time before the short start time period has elapsed. During normal running operations, the time between two consecutive pulses of the input shaft and output shaft should be within a preset time differential. If a condition occurs where this time differential is exceeded (slip condition), the control will de-energize the solenoid valve, thereby disengaging the clutch.

2.3.2 The number of starts and JOGs is also monitored by the control. To prevent excessive heat generation and damage to the clutch, the control will allow a maximum of three starts or JOGs within a ten minute period. Attempting more than three starts or JOGs within this window will force the control into a cool-down mode, preventing further start attempts until the user defined cool-down period has expired.

2.3.3 Warning lights alert the operator to any of the fault conditions and are explained in detail in Section 5.0 - Fault Description And Reset Procedures.

3.0 Installation

3.1 Factory setup

3.1.1 The following features are available on the slip detection control systems. With regard to items (b) through (i), these features have factory set defaults as described below, however, these features are user configurable and can be changed by the customer. Please review the factory set defaults and carefully consider the overall safety and performance of the system before making any changes to the factory set defaults.

Note: Changes made to the factory set defaults will not be retained if power is lost and the system reboots. A log sheet is attached at the back of this document to use for keeping track of any changes made to the factory set default values so that they can be restored by the user. By momentarily energizing reset switch 4SS on the inside of the panel all values will be reset to their factory set default values.

(a) Optional control - JOG and BYPASS feature.

(b) Start mode delay time

This is the delay time that will occur between the time a local or remote start is initiated and the time the clutch air system solenoid valve is energized. The warning horn output will be high and the mill running light on the HMI will flash during this delay time. The default value for this delay time is 10 seconds.

(c) JOG mode delay time

This is the delay time that will occur between the time a local JOG is initiated and the time the clutch air system solenoid valve is energized. The mill running light on the HMI will flash during this delay time. The default value for this delay time is 0.1 seconds.

(d) Long start window

This is the maximum amount of time that is allowed for the clutch to come to full motor speed before a long start is declared. When a long start is declared the solenoid valve is de-energized and the fault light on the HMI will light continuous. The fault must be reset at the panel before another start can be attempted. The default value for the long start time is 9 seconds for panel part number 209825-103 and 7 seconds for panel part number 209825-109.

(e) Short start window

This is the minimum amount of time that is allowed for the clutch to come to full motor speed. If the clutch comes to full motor speed in less than this amount of time a short start is declared. When a short start is declared the solenoid is not de-energized but the short start warning light on the HMI will flash for 3 minutes to warn the user that a short start has occurred. The default value for the short start time is 3 seconds.

(f) Restart delay

This is the amount of time that must pass between the time the output shaft stops rotating and the time another start attempt is allowed. The default value for the restart delay is 30 seconds.

(g) Cool down window

This is the amount of time that must pass between the time the user accumulates 3 starts or JOGs, or a combination thereof, within a 10 minute time frame and the time another start or JOG will be allowed. During the cool down period the fault light on the HMI will flash at 1Hz. This fault cannot be reset, the cool down period must be allowed to elapse and then the system will reset automatically. The default value for the cool down window is 30 minutes. A display on the maintenance screen of the HMI provides the elapsed time since the cool down period began. See Figure 8 for the layout and information contained on the maintenance screen.

(h) Percent slip

This is the maximum allowable difference in percent of speed that is allowed to occur between the output shaft and the input shaft before the system declares a slip condition. If a slip condition is declared the solenoid valve will be de-energized and the fault light on the HMI will light continuous. The fault must be reset at the panel before another start can be attempted. The default value for the percent slip is 10%.

(i) Persistence

This parameter works together with the percent slip parameter (h). This is the maximum allowable number of revolutions that the output shaft will be allowed to travel at the maximum allowable percent slip before a slip condition is declared. This parameter should be kept as tight as possible without inducing nuisance faults. The default value for the persistence is 5 revolutions.

The above defaults will be pre-programmed in the PLC at Eaton Airflex before shipment. Refer to Figure 6 for the layout of the configuration screen and the location of these parameters on the HMI.

WARNING

When servicing the equipment operated by this control, the service disconnect must always be locked out and tagged out per OSHA requirements (29 CFR Part 1910). Always use a lock on the service disconnect for this control as well as the motor controller.

3.2 Control panel

- 3.2.1 The control should be installed by a qualified electrician and wired in compliance with the National Electrical Code.
- 3.2.2 Ensure the cabinet is properly grounded.
- 3.2.3 Proper wiring techniques are essential to assure the inherent safety features of the Airflex control system. Use only accepted methods of installing conduit and 14 gauge stranded machine tool wire (U.L. Listed, 105°C temperature rating, oil resistant) for wiring components to the control panel.
- 3.2.4 Wire in accordance with the control schematic provided by Eaton Airflex for your particular system.

3.3 Sensor target installation

- 3.3.1 Accurate and reliable operation of the Slip Detection feature of the control is dependent upon installation and proper set-up of the proximity sensor targets. Targets and fasteners are included as a part of the control package.

⚠ WARNING

The use of items other than factory supplied targets as sensor targets may result in faulty operation of the control.

- 3.3.2 The slip detection control only requires the use of one target on the input side and one target on the output side for proper operation. If it is suspected that the single target arrangement is causing vibration in the system then a second target should be added to each side to offset the weight of the single target. Mount the second target 180 degrees from the first target and turn it so that it will not trigger the proximity sensor. If it is not possible to mount a second target so that it will not trigger the proximity sensor then a weight should be made, equal to the weight of the target, and mounted 180 degrees from the target.
- 3.3.3 Targets should be mounted at a diameter equal to or less than that of the clutch spider or drum hub area. Clutch applications purchased as a package with the control will be pre-drilled to accept the target fasteners.
- 3.3.4 Orientation of the target is dependent upon ease of drilling and tapping of the hubs to accept the fasteners. Recommended position is similar to that shown in Figure 1, to allow for ease of clutch maintenance without disturbing the position of the proximity sensors. Target orientation shown in Figure 2 allows for radial fastener installation in the event that axial clearance is limited. Ensure that the target location will not interfere with guarding or adjoining bearing housings., etc. that may damage the target during operation.

3.4 Proximity sensors

See Figure 3 for System Diagram

- 3.4.1 To ensure that the proximity sensors deliver a pulse to the control of sufficient magnitude, the proximity sensors cable lengths should not exceed 33 feet (10 meters).
- 3.4.2 It is required that the proximity sensors wires be run inside a dedicated conduit to prevent any EMI or RFI noise interference. Install conduit as close to the sensor as possible with a minimal amount of exposed cable.
- 3.4.3 To eliminate exposed cable completely, use a box to house the proximity sensor and a piece of liquid tight flexible metal conduit for the last few feet of cable.
- 3.4.4 Proximity sensors should be mounted to a rigid bracket or fixture to restrict movement during operation.
- 3.4.5 Proximity sensors must be located with a maximum gap of 5/16 of an inch (0.312") from the targets.

Note: Avoid locating the proximity sensors too close to the target to eliminate any possibility of the target striking and damaging the proximity sensors.

- 3.4.6 After installation of the targets and proximity sensors, check for proper clearance by slowly rotating the motor shaft and driven shaft. If the proximity sensors are reading properly LED's 4 and 5 on the front of the XC-CPU201 processor will light accordingly. See Table 1. & 2

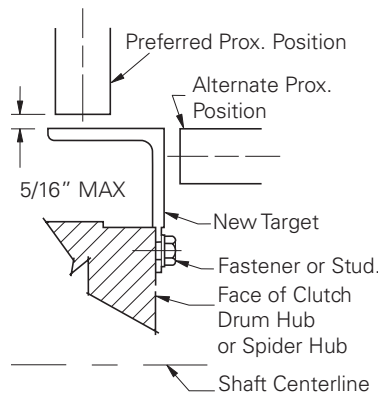

Figure 1

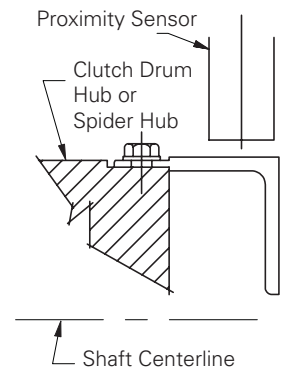

Figure 2

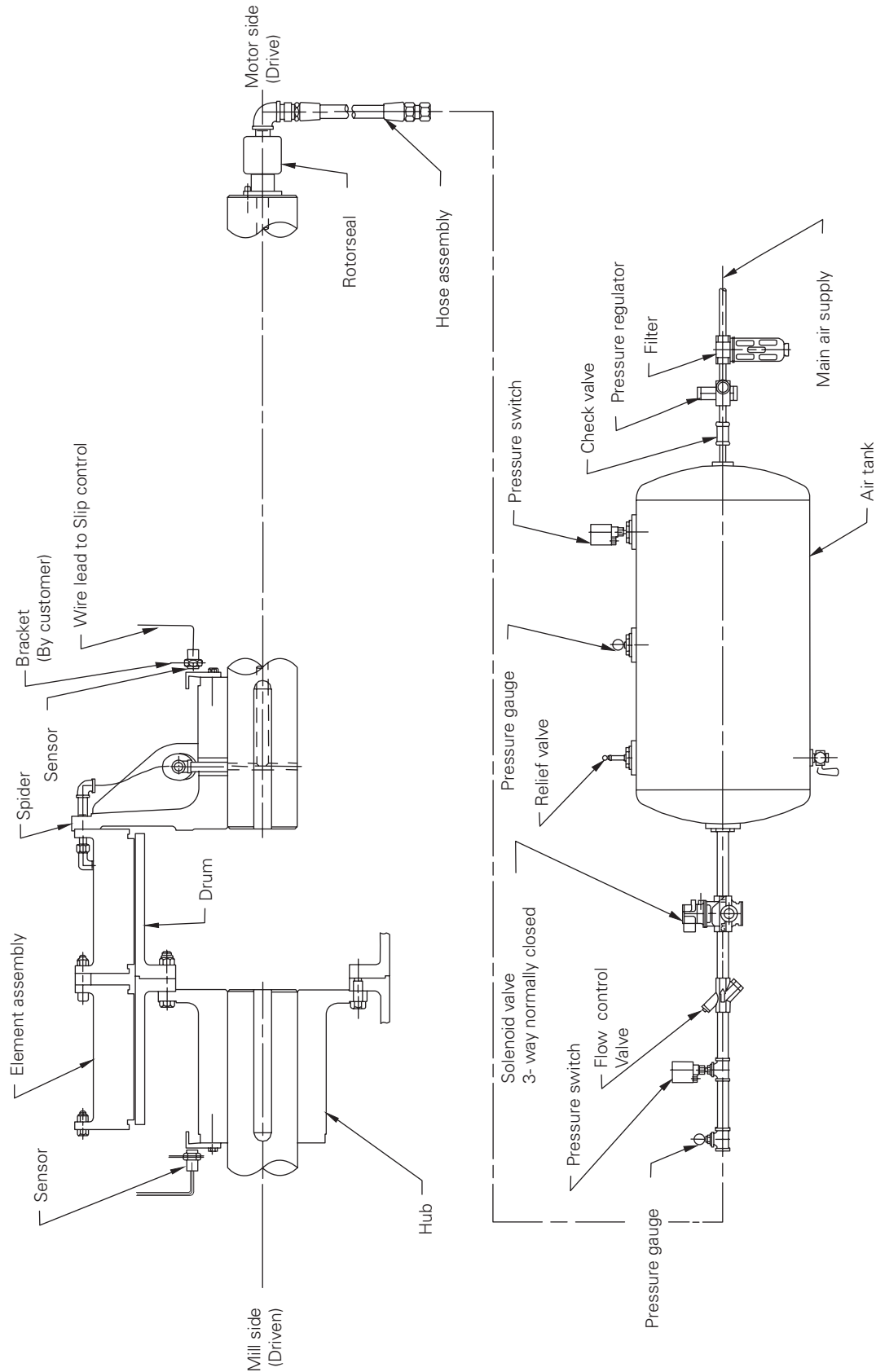

Figure 3

4.0 Specific operation

This section is intended to provide the operator with the necessary information to operate the mill and recognize any fault conditions. Section 5.0 - Fault description and reset procedures will give a detailed explanation of faults and the required steps to reset them.

Refer to Figure 4 for references to the panel door, refer to Figures 5 through 8 for references to the HMI screens.

Note: The layout of the HMI screens may vary slightly depending on the features ordered.

4.1 Mode selection HMI Pushbuttons

4.1.1 OFF

When the mode selection is in the OFF position, the mill control panel is off, and any action made on the control panel will not engage the clutch.



WARNING

Do not rely on this switch for shut down while servicing. Always use the service disconnect switch when working on equipment.

4.1.2 JOG

When JOG has been selected in the Mode Selection area of the Operating Screen, the MILL JOG pushbutton will engage the clutch when the prestart JOG delay period is over. The MILL JOG pushbutton must be held in until the jogging operation is over. The green mill running light will flash until the pre-start JOG delay period is over. After the delay period, the clutch will engage and the green mill running light will go solid. Releasing the MILL JOG button will disengage the clutch and the green run light will go out. There is a 10 second maximum time allowed for the JOG operation. If the user attempts to JOG the mill for more than 10 seconds the system will automatically abort the JOG operation.

4.1.3 RUN LOCAL

When RUN LOCAL has been selected in the Mode Selection area of the Operating Screen, the MILL RUN pushbutton on the HMI operating screen will activate the clutch after the start delay period.

4.1.3.1 The MILL RUN circuit has a holding circuit, so the MILL RUN pushbutton does not have to be held in during the start delay period. The green MILL RUNNING light will flash and the WARNING HORN output will be high until the start delay period is over. The clutch will then engage and the MILL RUNNING light will go solid. The clutch will continue to run until either the MILL STOP pushbutton on the operating screen of the HMI or the MILL STOP pushbutton on the panel door is depressed or a fault condition occurs.

4.1.4 RUN REMOTE

When RUN REMOTE has been selected in the Mode Selection area of the Operating Screen, the mill may be started from a remote panel. The start delay time remains in effect for a remote start just as for a local start. Refer to the drawings for your specific panel for instructions on where to connect the remote start input. The MILL RUN pushbutton on the control panel will not start the clutch in RUN REMOTE mode. The MILL RUN circuit has a holding circuit, so the remote MILL RUN pushbutton does not have to be held in during the start delay period. The green MILL RUNNING light will flash until the start delay period is over. The clutch will then engage and the MILL RUNNING light will go solid. The clutch will continue to run until either the MILL STOP pushbutton on the operating screen of the HMI or the MILL STOP pushbutton on the panel door is depressed or a fault condition occurs.

4.1.5 MILL RUN LOCAL

The MILL RUN LOCAL pushbutton on the Operating Screen will activate the holding circuit then engage the clutch after the start delay time has elapsed.

4.1.6 MILL STOP

The MILL STOP pushbutton will disengage the clutch and its holding circuit. There is a MILL STOP pushbutton on the operating screen of the HMI and a MILL STOP pushbutton on the panel door. Either MILL STOP pushbutton will stop the mill. The MILL STOP button on the panel door is a momentary contact pushbutton and the MILL STOP button on the HMI is a detent pushbutton. The MILL STOP button on the HMI will remain in the mill stop mode until the button is pressed again to release the MILL STOP function. The background around the MILL STOP button on the HMI will be red when it is latched in the MILL STOP mode.

4.1.7 SLIP DETECTION BYPASS/NORMAL

A keyed selector switch inside the control panel provides the means to bypass the slip monitoring function of the control under special circumstances. The SLIP DETECT BYPASS light on the operating screen of the HMI will be on when the system is in the BYPASS mode to warn the user that the system is in BYPASS and there is no protection for the clutch.

4.1.7.1 When the switch is in the bypass position, the control will disregard any slippage or fault condition.



WARNING

Operation of the control in bypass mode prevents slip detection and other system monitoring during start-up and operation of the clutch.

4.2 General operation

4.2.1 The green RUN/STOP LED on the face of the PLC must be on solid for the mill to run. If the green LED is not on or it is blinking, consult Section 6.0 - TROUBLESHOOTING for details.

4.2.2 To engage the clutch:

- (a) Verify that all required interlocks are connected per the drawings and that the READY TO RUN light on the operating screen of the HMI is on. Place the OFF-RUN LOCAL-JOG-RUN REMOTE switch in the desired operating mode.
- (b) If JOG operation is desired, depress JOG in the Mode Selection area of the Operating Screen and depress and hold the MILL JOG pushbutton. To release the clutch, release the MILL JOG pushbutton.
- (c) If starting the mill from the local panel is desired, depress RUN LOCAL in the Mode Selection area of the Operating Screen and then depress the MILL RUN LOCAL pushbutton on the Operating Screen.
- (d) If starting the mill from a remote operating station, depress RUN REMOTE in the Mode Selection area of the Operating Screen and then depress the MILL RUN pushbutton at the remote station.
- (e) To stop the mill, depress the MILL STOP pushbutton from either remote or local control panels.

4.2.3 When the MILL RUN LOCAL or MILL JOG pushbutton is pressed, the mill run indicating light will flash until the prestart delay is over. When the prestart delay is over, the clutch will start to engage and the indicating light will stay on solid. The background of the Mill RUN LOCAL and MILL JOG pushbuttons on the operating screen of the HMI will flash according to the number of starts and JOGs that have been performed or attempted in a 10 minute time frame. This is to let the user know if they are about to reach the maximum allowable start/JOG limit. The number of starts and JOGs that have been accumulated in the 10 minute time frame can also be seen on the history screen of the HMI. Refer to Figure 7 for the layout of the history screen of the HMI and the information available. Also refer to section 3.1.1, item (g) for additional description of the cool down timer

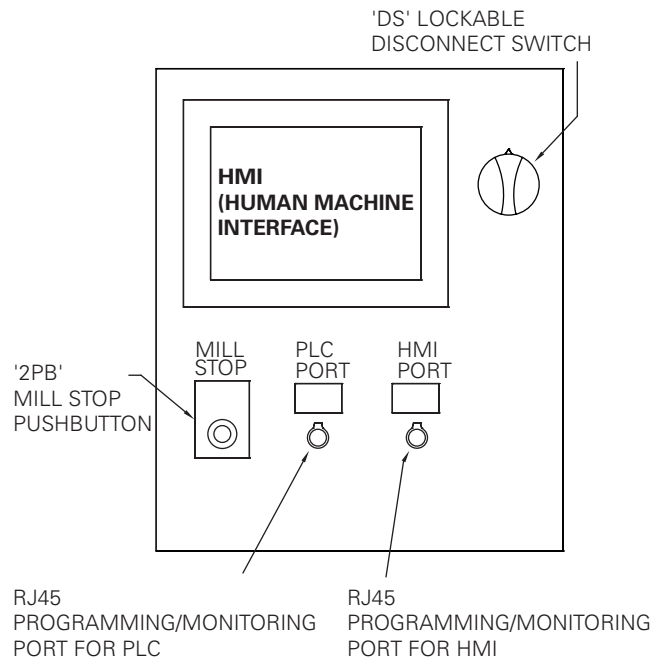

Figure 4

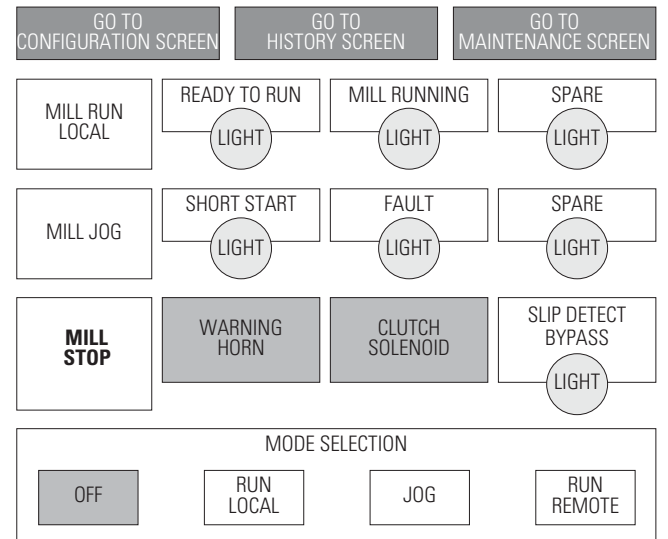

Figure 5

CP3110 Grinding Mill Slip Detection Control

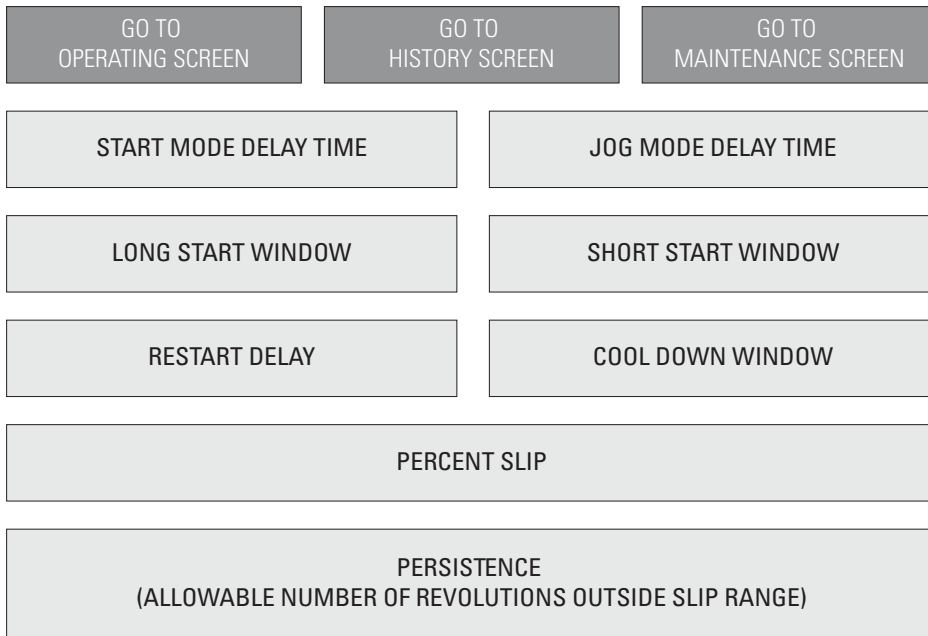

Figure 6

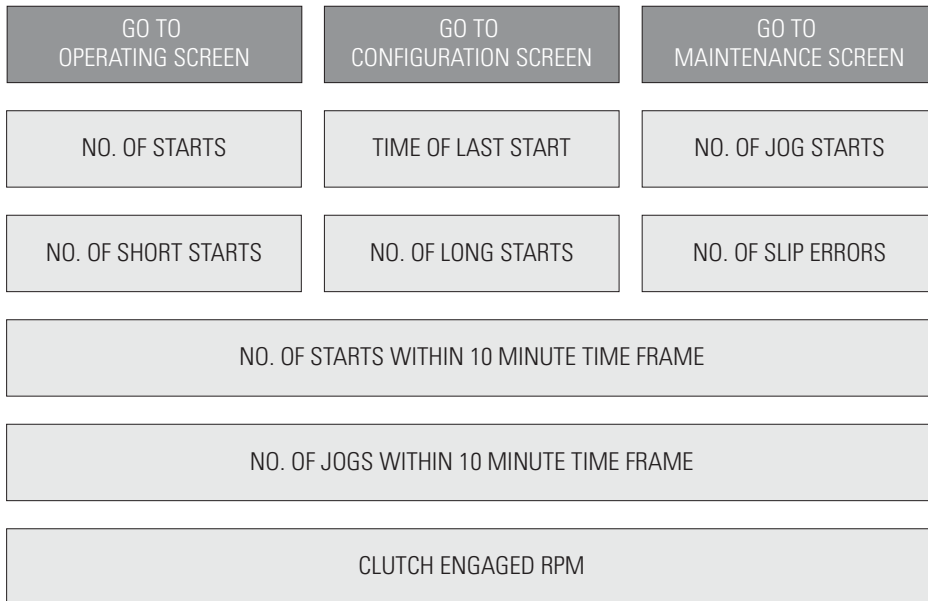

Figure 7

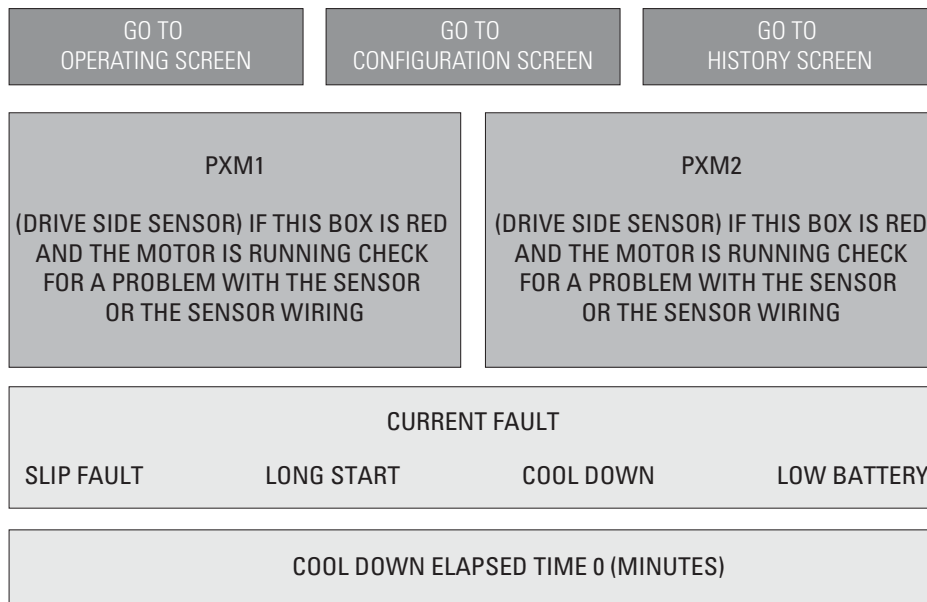

Figure 8

5.0 Fault description and Reset procedures

5.1 Indicating Lights

5.1.1 All indicating lights for normal operation are on the operating screen of the HMI. Refer to Figure 5.

5.2 MILL RUNNING Light (Green)

5.2.1 If the MILL RUNNING light is:

OUT - The clutch is neither engaged nor attempting to engage.

FLASHING - The clutch is about to engage in either the JOG, local run, or remote run modes.

ON - The clutch is engaged and operating normally.

5.3 SHORT START light (white)

5.3.1 If the SHORT START light is:

OUT - A short start has not occurred.

FLASHING - The clutch has engaged too quickly. The light will time out after 3 minutes.

5.4 FAULT LIGHT (Red)

5.4.1 If the FAULT LIGHT is:

OUT - No fault has occurred.

FLASHING - If the fault light is flashing continuously at a rate of one second on and one second off the control is in the cool down mode.

If the fault light is flashing continuously at a rate of 3 seconds on and 1 second off the PLC battery is either low or dead. Replace the battery as soon as possible. The battery is located on the left side of the CPU unit. The battery can be replaced with the unit powered up and running, however, if the battery cannot be accessed for replacement with the CPU installed it will be necessary to shut down the system and remove the CPU unit to replace the battery. Refer to the bill of material for your system for the proper replacement battery.

ON - A fault condition has occurred. One of the following conditions is present:

- (a)** A long start has occurred. The clutch output side shaft did not come up to speed within the user defined long start window.
- (b)** A slip condition has occurred on the mill. This can occur any time after the clutch has engaged. The clutch was disengaged due to too much slippage.

5.5 Resetting a Fault

5.5.1 To reset a fault, the following procedure should be used at the local panel:

- (a) Depress OFF in the Mode Selection area of the Operating Screen.
- (b) Depress the MILL STOP pushbutton on the operating screen of the HMI.
- (c) Depress and hold the local MILL RUN pushbutton. At this time the red fault light will go out.
- (d) Release the MILL RUN LOCAL pushbutton and press the MILL STOP pushbutton to release the MILL STOP mode.

5.5.1.1 If the fault light stays out, the fault is cleared and the mill is ready to restart as long as the reason is known. If the fault light stays on flashing, then the fault was due to attempting to engage the clutch more than three times within a ten minute period and you must wait for the cooldown period to expire. After that time you may attempt to start the mill once again. See the Maintenance Screen for the current elapsed time of the cool down period.

5.6 Operating Information

5.6.1 Various operating and historical information is available on the history screen of the HMI. Refer to Figure 7 for the layout of the history screen and the information available. The number of starts, number of JOG starts, number of short starts, number of long starts and number of slip errors is retained data. This data will be retained through a reboot. The other data on the history screen is not retained.

5.6.2 If the user wishes to enter either the HMI or PLC to view the program there are RJ45 ports on the door of the panel for access to either the HMI or PLC. The user will need to have the XSoft-CoDeSys V2.3.9 SP2 loaded on their PC and they must have the program open in XSoft-CoDeSys V2.3.9 SP2 in order to be able to connect with the HMI or PLC. A copy of the HMI and PLC programs have been loaded onto the SD card that is installed in the front of the PLC. The user must have these programs open in XSoft-CoDeSys V2.3.9 SP2 in order to be able to access the programs on the HMI and PLC. A standard Ethernet crossover cable is required for connection from the HMI or PLC programming port to the user PC. Consult your Eaton representative for additional information regarding this process.

5.7 Resetting the Information in the PLC

5.7.1 The following procedure can be used to reset the configuration variables in the program to their factory set values.

- (a) The mill should be stopped and at rest prior to resetting the PLC.
- (b) Turn the disconnect switch on the panel to the off position and open the panel door. Once the panel door is open it will be necessary to turn the disconnect switch back on manually to restore power to the PLC.
- (c) Using the keyed selector switch 4SS on the inside of the panel turn the switch from the RUN position to the RESET position. The configuration variables will now be restored to their factory set values.
- (d) Return the keyed selector switch to the RUN position and manually return the disconnect switch to the off position. Close the panel door and latch it properly.
- (e) Return the main disconnect switch to the on position and resume operation of the mill.

5.8 Resetting the HMI

5.8.1 The following procedure can be used to reset the HMI or to access the windows operating screen of the display.

- (a) The mill should be stopped and at rest prior to resetting the PLC.
- (b) Turn the disconnect switch on the panel to the off position and open the panel door. Once the panel door is open it will be necessary to turn the disconnect switch back on manually to restore power to the PLC.
- (c) Press the small red button on the side of the HMI. This will prompt you to shutdown or restart the PLC.
- (d) Manually return the disconnect switch to the off position. Close the panel door and latch it properly.
- (e) Return the main disconnect switch to the on position and resume operation of the mill.

6.0 Troubleshooting

6.1 Clutch

6.1.1 The clutch will not engage at all.

- (a) The motor is not running.
- (b) There is no power to the PLC.
- (c) The PLC is not running.
- (d) There is a fault.
- (e) The DC power supply has failed.
- (f) The selector switch is in the off position.
- (g) The valve has failed.
- (h) There is no air pressure.

6.1.2 **The clutch will engage for a short time but then aborts with a fault light.**

- (a) There are no inputs from the sensors.
- (b) There is no DC power from the supply.
- (c) There was a long start situation.

6.1.3 **The clutch will engage for some time, then drops out with no fault light.**

- (a) The stop button was depressed.
- (b) There was no signal from the input sensor.

6.1.4 **The clutch will engage for some time, then drops out with a fault light.**

- (a) There was a long start.
- (b) There was a slipping condition on the clutch.
- (c) The signal from one of the sensors was lost.

6.1.5 **The clutch will engage for an extended period of time, then drops out with a fault light.**

- (a) There was a slipping condition on the clutch.
- (b) The signal from one of the sensors was lost.

6.2 Control panel

6.2.1 **The HMI will not control the system.**

- (a) The PLC is not running.
- (b) There is no main power.
- (c) The system requires a reboot.

Note: User modified configuration values will be lost following a reboot.

6.2.2 **The indicating lights are on**

- (a) Check Section 4.0 - Specific Operation and Section 5.0 - Fault Description And Reset Procedures to see what the current situation is.

6.2.3 **The OFF-JOG-RUN LOCAL-RUN REMOTE Mode Selection area on the HMI screen is not functioning.**

- (a) The PLC is not running.
- (b) The connection between the HMI and the PLC has failed.
- (c) The PLC requires a reboot.

Note: User modified configuration values will be lost following a reboot.

6.2.4 The HMI is not functioning.

- (a) DC power supply has failed.
- (b) The HMI has failed.
- (c) The system requires a reboot.

Note: User modified configuration values will be lost following a reboot.

6.3 PLC

6.3.1 **The RUN/STOP light is off.**

- (a) There is no DC power to the PLC.

6.3.2 **The RUN/STOP light is flashing.**

- (a) The CPU has been put in the stop mode due to a very high or a very low incoming voltage condition.
- (b) The unit was shipped from the factory in the stop mode. The PLC program must be restarted with a laptop computer. Contact an Eaton Airflex representative.

6.3.3 **The RUN/STOP light is on.**

- (a) The PLC is running in a normal condition.

6.4 I/O

6.4.1 To check all the inputs (pushbuttons and hardware) to make sure the PLC is receiving the signal, refer to Table 1 & Table 2 to assist in locating the specific PLC LED's.

6.4.2 To check all the outputs to make sure the PLC is sending the proper signals, refer to Table 2 to assist in locating the specific PLC LED's.

7.0 Ordering information/technical assistance

In any correspondence regarding Airflex Equipment, refer to the information on the product nameplate and call or write:

Eaton Hydraulics Group
 USA Airflex Products
 9919 Clinton Road Cleveland,
 Ohio 44144 USA
 Tel: 216-281-2211
 Fax: 216-634-3890
 www.eaton.com/airflex

Table 1 Input devices for part number 209825-103

Input	CPU or Module Location	I/O LED	Condition when function is active
Proximity Switches			
Proximity Switch #1	XC-CPU201	4	ON
Proximity Switch #2	XC-CPU201	5	ON
Push Buttons			
MILL RUN (Remote)	XIOC-16DI	9	ON
MILL STOP	XIOC-16DI	1	OFF
Keyed Selector Switches			
Reset	XIOC-16DI	0	ON
Optional Bypass	XIOC-16DI	11	ON

Table 2 Input devices for part number 209825-109

Input	CPU or Module Location	I/O LED	Condition when function is active
Proximity Switches			
Proximity Switch #1	XC-CPU201	4	ON
Proximity Switch #2	XC-CPU201	5	ON
Push Buttons			
MILL RUN (Remote)	XC-CPU201	1	ON
MILL STOP	XC-CPU201	2	OFF
Keyed Selector Switches			
Reset	XC-CPU201	0	ON
Optional Bypass	XC-CPU201	3	ON

Table 3 Output devices

Input	CPU or Module location	I/O LED	Condition when function is active
Customer Devices			
Clutch solenoid valve	XC-CPU201	1	ON
Warning horn	XC-CPU201	3	ON
System Status Indications			
Solenoid valve	XIOC-12DO-R	0	ON
Fault	XIOC-12DO-R	1	ON
Short start warning	XIOC-12DO-R	2	ON
Mill running	XIOC-12DO-R	3	ON
Start-up alarm	XIOC-12DO-R	4	ON
Slip detection bypass	XIOC-12DO-R	5	ON

8.0 Appendix

This sheet can be used to keep track of changes made to the factory set default values.

Configuration parameter	Default value	User modified value 1	User modified value 2
Start mode delay time	10 seconds		
JOG mode delay time	100 milliseconds		
Long start window	9 seconds for 209825-103 7 seconds for 209825-109		
Short start window	3 seconds		
Restart delay	30 seconds		
Cool down window	30 minutes		
Percent slip	10%		
Persistence	5 revolutions		

Revisions

Revision date	Change	Page
April 2018	Added "(used with VC clutch applications) and 209825-109 (used with VC and HEVC clutch applications)"	2
	Added "and HEVC" in section 1.2	4
	Added 7 seconds for panel part number 209825-109 in section 3.1.1 (d)	5
	Added Table 2 Input devices for part number 2209825-109	14
	Added "7 seconds for 209825-109" in table in 8.0 Appendix	14

Eaton
 1000 Eaton Boulevard
 Cleveland, OH 44122
 United States
 Eaton.com



© 2018 Eaton
 All Rights Reserved
 Printed in USA
 Publication No. E-CLCL-II020-E/5426
 May 2018

Eaton is a registered trademark.

All trademarks are property of their respective owners.