

CA10000 - 225DP100 Caliper Disc Brake Assembly
Installation, Operation and Maintenance Manual
Airflex® Product Line



EATON

Powering Business Worldwide

Table of contents

IOM part number: 204107 Rev. A

Section	Description	Page
1.0	INTRODUCTION	5-6
1.1	Description	5
1.2	How it works	5-6
2.0	INSTALLATION	6-7
2.1	Preparation	6-8
2.2	Mounting	7
2.3	Actuating Supply Systems	8
3.0	OPERATION	8-9
3.1	Conditions of Operation	8
3.2	Pressure, Speed, and Temperature Limits	8
3.3	Wear in Procedure	8
3.4	Periodic Inspection	9
4.0	MAINTENANCE	9-11
4.1	Periodic maintenance	9
4.2	Wear Limits	9
4.3	Friction Shoe Assembly Inspection & Replacement	9-10
4.4	Seal Replacement	10-11
4.5	Piston Replacement	11
5.0	ACCESSORIES	12
5.1	Pressure Intensifiers – Air over Hydraulics	12
6.0	ORDERING INFORMATION/TECHNICAL ASSISTANCE	12
6.1	Equipment Reference	12
7.0	PARTS	13
7.1	Basic Assemblies	13
8.0	KITS	14
8.1	Seal Kit	14
8.2	Piston Replacement Kit	14
8.3	Friction Shoe Assemblies	14
9.0	REVISION PAGE	15

Index of tables

Table No.	Table Title	Page
1	Item Description	4
2	Fastener Description and Assembly Torque - ft.-lb. (Nm)	7

225DP100 caliper disc brake assembly

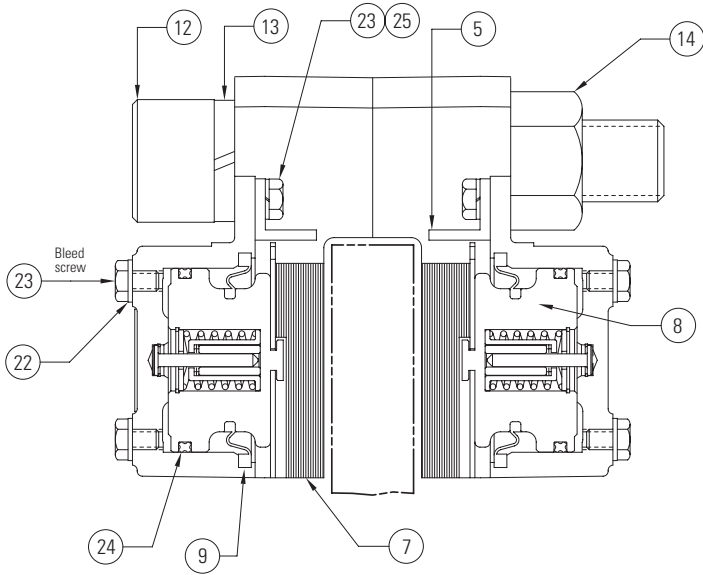

Figure 1

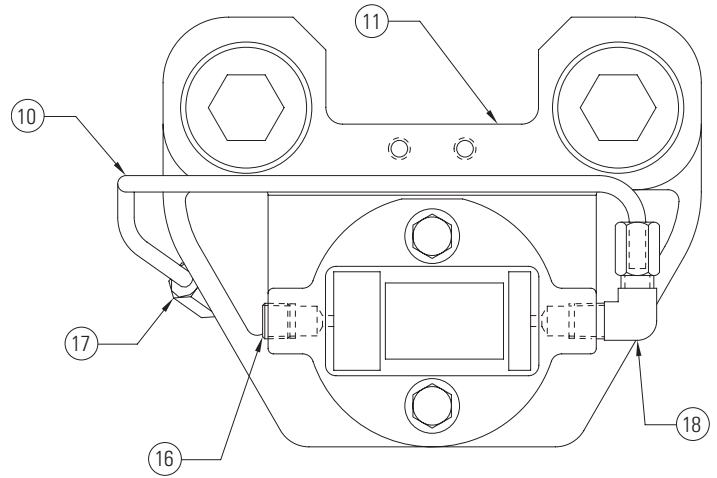

Figure 2

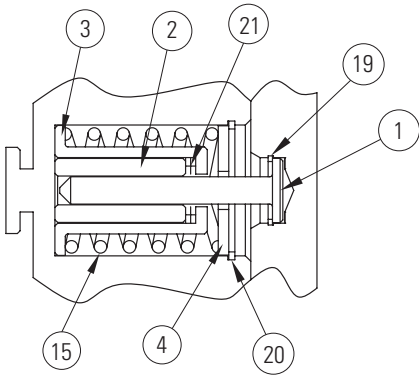

Figure 3

Table 1
Item Description

Item	Description
1	Pin
2	Sleeve
3	Spring Guide
4	Washer
5	Friction Shoe Retainer
7	Friction Shoe Assembly
8	Piston
9	Boot

Item	Description
14	Hex Nut
15	Spring
16	Pipe Plug
17	45 Degree Elbow
18	Elbow
19	Snap Ring
20	Snap Ring
21	Retaining Ring
22	Dyna Seal
23	Hex Head Cap Screw
24	Quad Ring
25	Lockwasher

225DP100 caliper disc brake assembly

1.0 INTRODUCTION

Throughout this manual there are a number of HAZARD WARNINGS that must be read and adhered to in order to prevent possible personal injury and / or damage to equipment. Three signal words "DANGER", "WARNING", and "CAUTION" are used to indicate the severity of a hazard, and are preceded by the safety alert symbol.



Danger

Denotes the most serious hazard, and is used when serious injury or death WILL result from misuse or failure to follow specific instructions.



Warning

Used when serious injury or death MAY result from misuse or failure to follow specific instructions.



Caution

Used when injury or product / equipment damage may result from misuse or failure to follow specific instructions.

It is the responsibility and duty of all personnel involved in the installation, operation and maintenance of the equipment on which this device is used to fully understand the ! Danger, ! Warning, and ! Caution procedures by which hazards are to be avoided.

1.1 Description

1.1.1 The Eaton Airflex 225DP100 caliper disc brake assembly is ideally suited for many high torque, high energy stopping applications. By properly choosing actuating pressure, number of calipers per disc, number of discs and disc diameter, a braking system can be custom designed for a wide variety of applications.

1.1.2 The Airflex 225DP100 caliper disc brake assembly is supplied with long wearing, NON-ASBESTOS friction material.

1.1.3 The Airflex 225DP100 caliper disc brake assembly is of the opposed piston design. This design permits fixed mounting of the 225DP100 caliper disc brake assembly and the disc. Symmetrical split construction of the piston housing permits a center reaction mounting and the ability to accommodate discs of different thicknesses. Friction shoe assemblies (7) attach to the 225DP100 caliper disc brake actuating pistons (8) and are replaceable without disturbing the caliper mounting. Applying hydraulic or pneumatic pressure to the piston cylinders causes the piston-mounted friction shoes assemblies to clamp the disc, developing the braking torque. The braking power is directly proportional to the applied pressure and disc diameter.

1.1.4 The 225DP100 caliper disc brake assembly is self-adjusting compensate for friction material wear and maintains a constant running clearance between the friction shoes assemblies and disc. They also maintain a constant displacement volume and therefore a constant response time for each of the 225DP100 caliper disc brake assembly's engagement.

1.1.5 The 225DP100 caliper disc brake assembly can be pneumatically or hydraulic actuated. The pressurizing media must be specified to insure proper piston seal compatibility. Two types of seals (22) are available: one for air and mineral base fluids, and the other for vegetable base fluids.

1.1.6 Low coefficient friction shoe assemblies (7) are available which permit the 225DP100 caliper disc brake assembly to be used as tension brakes.

1.1.7 Maximum allowable operating pressure is 1000 psig (69 bar). For those installations not equipped with a high-pressure power source, a pressure intensifier can be used to provide the required pressure. This device converts a low air pressure input into a high hydraulic pressure output.

1.1.8 This manual includes metric equivalents usually shown in parentheses (#) following the U.S. measurement system value.

1.1.9 The disc that the 225DP100 caliper disc brake assembly engages on can be purchased or manufactured by the end user. A limited number of discs are available from Eaton. Contact your local distributor for details.

1.2 How It Works

1.2.1 Throughout this manual, explanations mentioning specific components of the 225DP100 caliper disc brake assembly are often followed by numbers in parentheses, which refer to the item numbers in Table 1 and on Figures 1, 2 and 3; for example, friction shoe assembly (7).

1.2.2 Air or hydraulic pressure is introduced into the cylinder blocks at one of the two inlet openings (16). The bridge pipe (10) connects the two cylinders (11), assuring equal pressure on both sides. Both pistons (8) move simultaneously and squeeze the piston-mounted friction shoe assemblies (7) against the disc, causing a braking action.

1.2.3 When the actuation pressure is released to zero psig (zero bar), a spring-powered, self-adjusting release mechanism retracts the pistons and associated friction shoes from the disc.

1.2.4 The shoe retraction and self-adjusting mechanism is contained inside of the caliper piston (8). The assembly is completely inside the caliper cylinder block (11) and is not subject to tampering or contamination by foreign matter. The wear adjustments are done automatically and no maintenance is required throughout the life of the friction shoes. See Figure 3.

225DP100 caliper disc brake assembly

- 1.2.5 A detailed description of the operation of the retractor mechanism is as follows:
- 1.2.5.1 Pin (8) is fixed to the cylinder block (11) by snap ring (19). Piston (8) is positioned by the retaining rings (21) which slide along pin (1). Spring (15) is retained in the piston by washer (4) and snap ring (20). The force required to slide the retaining rings along the pin is greater than the force developed by the spring.
- 1.2.5.2 When pressure is applied, the piston moves outward, compressing the spring until the washer (4) bottoms against the spring guide (3). The pressure, acting on the piston diameter, forces the retaining rings outward along the pin. When pressure is removed, the retaining rings maintain their new position on the pin. The spring then retracts the piston until the spring guide bottoms against the piston (8). The gap between the spring guide and washer is equal to the clearance between the disc and friction pad.

2.0 INSTALLATION



Warning

Prior to installation of the 225DP100 caliper disc brake assembly, the machinery shall be locked in a secured position. Failure to do so could result in serious personal injury or possibly death.

2.1 Preparation

- 2.1.1 Varying disc thicknesses can be accommodated by inserting spacers between the two cylinder blocks (11).
Note: Varying the disc thickness will require new or modification of the bridge piping.
Note: Minimum disc diameter is 9.93" (240 mm). A standard disc thickness of 1.000" the tolerance is +0.00" / - 0.010" (25.5 mm) (+0.00 mm / -0.25 mm)



Warning

Inserting spacers between the two cylinder blocks will require new/modification of the bridge piping.

- 2.1.2 If a 225DP100 caliper disc brake assembly mounting bracket is fabricated, it must allow the 225DP100 caliper disc brake assembly to butt against the lip adjacent to its machined surface. This bracket must also be of sturdy construction and rigidly mounted to prevent deflection during operation. It is recommended that two tapped holes (1" 8NC-3 thread) be provided with enough thread engagement allowing the socket head screws (12) to be tightened at 590ft. /lbs. (800 Nm). If thru holes are fabricated into the mounting bracket the hole size should be 1-1/32" (26.2 mm) maximum.



Caution

Before locating the holes for drilling in the mounting bracket, make sure the 225DP100 caliper disc brake friction shoe assemblies (7) will completely engage the disc. The friction material should not overhang the outer edge of the disc. The outside diameter (O.D.) of the disc must not rub against the cylinder block (11). See Figure 4.

225DP100 caliper disc brake assembly

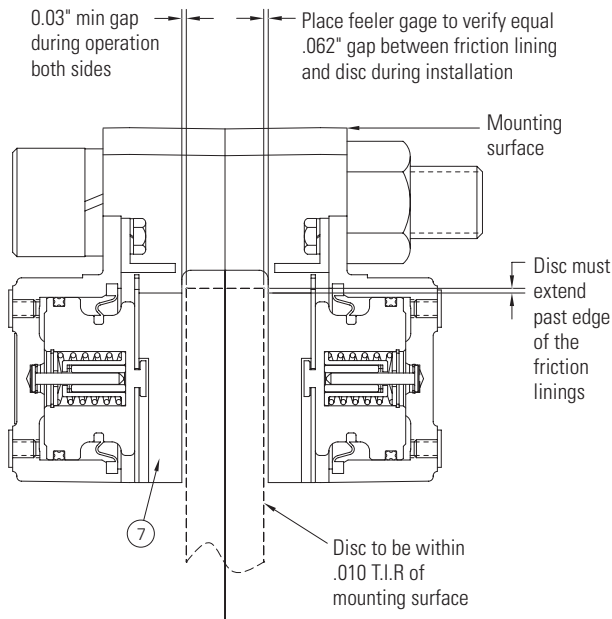

Figure 4



Warning

The nuts (14) provided with the 225DP100 caliper disc brake assembly for permanent mounting or assembly is grade 8. These nuts provided prior to February 2015 were for shipping purposes and were grade 2, and are not capable of being tightened to the required torque value. It is recommended to verify the grade nut with the 225DP100 caliper disc brake assembly.

- 2.1.3 The friction shoe assemblies (7) should be protected from contamination by oil, grease, dirt or excessive moisture.



Warning

Contamination of the friction material could result in erratic or loss of torque.

- 2.1.4 Verify or set the initial gap between the friction shoes assemblies and the disc to approximately 0.063" (1.6 mm). See figure 4.

2.2 Mounting the 225DP100 caliper disc brake assembly

- 2.2.1 The disc should be installed prior to mounting the 225DP100 caliper disc brake assembly. The maximum allowable runout of the disc should be verified to be no greater than 0.010" (0.25 mm).
- 2.2.2 The 225DP100 caliper disc brake assembly can be installed using mounting surfaces located on either side of the 225DP100 caliper disc brake assembly. See Figure 4.
- 2.2.3 It is very important that the mounting bracket be properly aligned with the mounting surface of the 225DP100 caliper disc brake assembly. For proper operation and service life, alignment of the mounting flange to the shaft of the disc gear should be held within the limits shown in Figure 4. Note: that concentricity and perpendicularity values in Figure 4 are expressed as TIR (Total Indicator Reading) values.
- 2.2.4 Before final tightening of the mounting screws, engage the 225DP100 caliper disc brake assembly, tighten the screws, release the 225DP100 caliper disc brake assembly and check that the alignment is within the values in Figure 4.
- 2.2.5 After final tightening of the mounting screws, apply the 225DP100 caliper disc brake assembly and release the 225DP100 caliper disc brake assembly. Then recheck that the alignment is within the values in Figure 4.



Caution

When the bridge pipe (10) is installed it passes across the top of one of the cylinder blocks (11) before attaching to the other cylinder block. DO NOT mount the 225DP100 caliper disc brake assembly on the side where the bridge pipe would cause interference.

Note: The 225DP100 caliper disc brake assembly is symmetrical to avoid the bridge pipe interference. The unit can be positioned for either direction of rotation as required.

Note: For hydraulic actuation installations, install the 225DP100 caliper disc brake assembly with the bleeder holes as high as possible to allow for the removal of the air from the hydraulic system. See Figure 1 and Table 1.

- 2.2.6 The socket head screws (12) and locking washers (13) are furnished to mount the 225DP100 caliper disc brake assembly, and should be tightened to the appropriate torque value. See Table 2.

Table 2
Fastener Description and Assembly Torque - ft.-lb. (Nm)

Item	Description	Specification	225DP100
12	Socket Head Mounting Screw	Size	1"-8 NC-3
		Quantity	2
		Torque, Lubed	590 (800)
12	Hex Head Cap Screw	Size	1/4-20 NC-2
		Quantity	8
		Torque, Dry	7 (10)

225DP100 caliper disc brake assembly

2.3 Actuating Supply Systems



Warning

Maximum allowable pressure is 1000 psig (69 bar). Application of pressure exceeding maximum allowable may result in damage to the 225DP100 caliper disc brake assembly.

2.3.1 Actuation medium can be supplied to the 225DP100 caliper disc brake assembly via one of the tapped holes in the cylinder block (11) or thru the bleed holes (23). See Figure 1 and 2. Pipe diameter is 1/8”

2.3.2 It is recommended that the piping connecting the actuating media to the 225DP100 caliper disc brake assembly be rated for the appropriate system pressures. Maximum allowable operating pressure is 1000 psig (69 bar).

2.3.3 Before assembly the actuation medium piping should be cleaned internally.

2.3.4 Hydraulically actuated systems require removal of air from the system when filling the system with the correct hydraulic fluid upon installation of the 225DP100.

2.3.4.1 There are two bleed screws (23) on the cylinder blocks (11). See Figure 1. The bleed screw on each of the two cylinders which are located at the highest level will be used to remove the air from the hydraulic fluid to the 225DP100 caliper disc brake assembly.

2.3.4.2 The mineral based fluid compatible seals are made from 366-Y-Buna-N material. Typical examples of mineral based fluids are hydraulic fluids and automotive automatic transmission fluids. Suggested fluids are:

- Mobil 24DTE Hydraulic Fluid
- Napa Automatic Transmission Fluid

2.3.4.3 The vegetable based fluid compatible seals are made from Buna-S (476S-GRS) material. Automotive brake fluid (DOT 3) is a typical example of vegetable based fluid. Suggested fluids are:

- Wagner 21B Brake Fluid
- Napa DOT 3 Brake Fluid

2.3.4.4 Loosen the selected bleed screw and apply enough hydraulic pressure allow all the air and a small amount of fluid to escape.

2.3.4.5 Retighten bleed screw once all air has been removed from the system.



Warning

Use the appropriate personal protective equipment (PPE).



Caution

Re-tighten the bleed screw (23) before releasing the applied pressure to avoid sucking more air back into the system.

3.0 OPERATION



Warning

Ensure adequate safety guarding is installed prior to operation.

3.1 Conditions of Operation



Warning

Friction material must be worn-in to achieve the 225DP100 caliper disc brake assembly's torque rating. For new installations or after repair, a minimum wear-in period may be required. Wear-in periods will very dependent on system pressure, disc diameter, finish, speed and material type Verify proper operation before putting the product into service.



Warning

Protective means must be used to prevent oil, grease, dirt or coolant from coming into contact with the surfaces of the friction material. Oil or grease on these parts will significantly reduce the torque capacity of the 225DP100 caliper disc brake assembly. Do not risk personal injury or damage to the equipment.



Warning

Operation at disc speeds and temperatures exceeding the maximum allowable by the friction material may result in exposure to personal injury or product/equipment damage. Consult the Airflex catalog or factory for the appropriate calculations.

3.2 Pressure, Speed, and Temperature Limits

3.2.1 Maximum applied pressure is 1000 psig (69 bar).

3.2.2 Due to the spring force, a minimum pressure of 8 psig (0.55 bar) is required to engage the friction shoes.

3.2.3 Maximum temperatures are application dependent. Consult the Airflex catalog or factory for the appropriate calculations.



Warning

Operation at disc speeds and temperatures exceeding the maximum allowable by the friction material may result in exposure to personal injury or product/equipment damage. Consult the Airflex catalog or factory for the appropriate speed and temperature calculations.

3.3 Wear in Procedure

3.3.1 The 225DP100 caliper disc brake assembly friction material will normally require a short wear-in period before generating full rated torque. Wear-in periods will very dependent on system pressure, disc diameter, finish, speed and material type Verify proper operation before putting the product into service.

225DP100 caliper disc brake assembly

3.4 Periodic Inspection



Caution

Periodic inspection will vary upon the specific wear rate per application. Periodic inspection intervals should be defined by maintenance or qualified personnel.

- 3.4.1 Inspect the friction material for wear as shown in Figure 5. If wear meets or exceeds the limits in Figure 5 proceed to section 4.3 for friction shoe replacement.

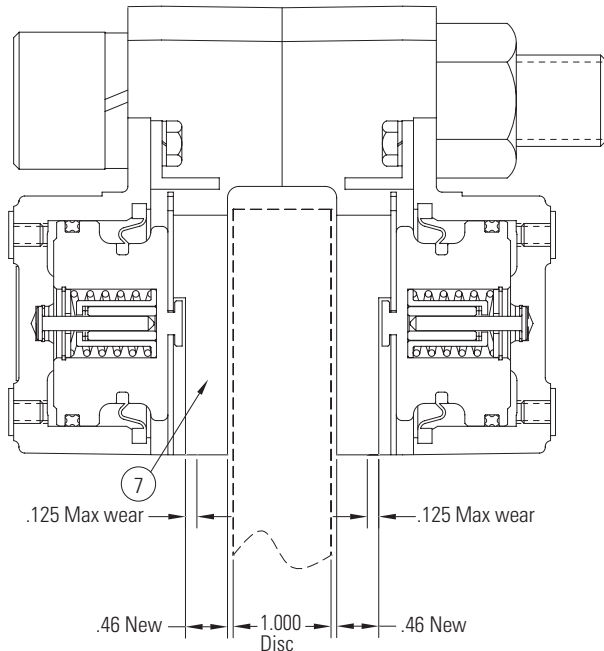

Figure 5

- 3.4.2 Inspect the 225DP100 caliper disc brake assembly for leaking actuation fluid. Should actuation fluid be leaking from the boot proceed to section 4.4 for seal replacement.
- 3.4.3 Inspect the 225DP100 caliper disc brake assembly for retraction of the piston assembly. Should the piston assembly not be retracting then proceed to section 4.5 for piston assembly replacement.

4.0 MAINTENANCE



Caution

When replacing components, use only genuine, Airflex replacement parts. Use of other materials may severely affect performance.

4.1 Periodic maintenance

- 4.1.1 Bleeding the hydraulic system

- 4.1.2 There are two bleed screws (23) on the cylinder blocks (11). Select the bleed screw on each of the two cylinders which are located at the highest level.



Warning

Use the appropriate personal protective equipment (PPE).

- 4.1.3 Gently loosen the selected bleed screw and apply enough actuation hydraulic pressure to allow the air and a small amount of fluid to escape.

- 4.1.4 Retighten bleed screw once air has been removed from the system.



Caution

Re-tighten the bleed screw (23) before releasing the applied pressure to avoid draining more air back into the system.

- 4.1.5 Repeat section 4.1.1 to 4.1.4 on both 225DP100 caliper disc brake assembly cylinders, and as many times as necessary to remove all the air bubbles from the system.

Note: Always bleed the system in a sequence starting from the point closest to the actuator and in succession at points further away.



Caution

During the bleeding operation, make sure that an adequate supply of fluid is available to prevent air from entering the system.

4.2 Wear Limits

- 4.2.1 Wear Limit for the 225DP100 caliper disc brake assembly friction material is shown in Figure 5. If the friction material wear limit has been reached or exceeded, replace the friction shoe assembly as required.

4.3 Friction Shoe Assembly Inspection & Replacement



Warning

Prior to the removal or installation of the 225DP100 caliper disc brake assembly friction shoe assembly the machinery shall be locked in secured position and that actuating systems are actually locked out or disconnected to prevent accidental actuation during maintenance. Failure to do so could result in serious personal injury or possibly death.

225DP100 caliper disc brake assembly



Caution

Use only genuine, Airflex friction material. Use of friction material not of Airflex origin may result in unpredictable 225DP100 caliper disc brake assembly performance and/or excessive wear of the 225DP100 caliper disc brake assembly components.

Note: There are no wear adjustments necessary with the 225DP100 caliper disc brake assembly.

- 4.3.1 Inspect the friction material to ensure that it is clean and free from oil and grease. Measure the material thickness for wear. See Figure 5 and to determine if the friction shoe assemblies require replacement. A new friction shoe assembly is 21/32" (16.7 mm) not including the steel backing plate. When the material thickness is worn to approximately 9/32" (7.4 mm) or within 1/8" (3.2 mm) of the mounting slot in the friction material, new friction shoe assemblies should be installed.



Caution

Damage to the piston will result if the material is allowed to wear beyond this point.



Warning

Contamination of the friction material could result in erratic or loss of torque.



Warning

Failure to replace the friction shoe assemblies as a set may result in damage to the 225DP100 caliper disc brake assembly and possible 225DP100 caliper disc brake assembly malfunction, degrading the stopping performance and ability to secure the load.

- 4.3.2 Friction material replacement

- 4.3.2.1 Verify that the wear limit has been reached as shown in Figure 5.

Note: The 225DP100 caliper disc brake assembly does not require removal in order to replace friction material.

Note: Inspect the surface of the disc for minimum thickness and condition. Replace or resurface the disc as required.

- 4.3.2.2 With the actuation pressure off, remove the four hex cap screws (23), lock washers (25), and friction shoe retainers (5) to allow the removal of the friction shoe assemblies (7).

- 4.3.2.3 Press the piston (8) all the way back in the cylinder. It may be necessary to loosen the bleed screws as shown in Figure 1 on the cylinder block (11) to bleed off the actuation pressure.

- 4.3.2.4 Install the friction shoe assemblies (7) by sliding the friction shoe assembly over the piston (8), and installing the friction shoe assembly retainer (5) with the hex head cap screws (23) and lockwashers (25). See Figure 1

4.4

Seal Replacement



Warning

Only qualified maintenance personnel should replace the boot or quad rings. Faulty workmanship may result in possible personal injury, 225DP100 caliper disc brake assembly malfunction or damage to the machinery.



Caution

Before proceeding, make sure that the correct seal kit is being used for the seal replacement. The quad ring (24) is designed to be used with a particular actuating medium; either air/mineral oil or vegetable base fluid. Proper kit part numbers for the different actuating medium are noted in section 8.1.



Caution

Use only genuine Airflex parts. Use of non-original Airflex parts may result in unpredictable performance.

- 4.4.1 The 225DP100 caliper disc brake assembly must be removed from the machinery in order to replace the boot (9) or quad ring (24).

- 4.4.2 Remove friction shoe assemblies (7) as explained in section 4.3

- 4.4.3 Remove the piston (8) and the boot (9). Clean the dust boot grooves in the cylinder block (11).



Caution

Keep dust boot groove free of contamination.

- 4.4.4 Remove the quad ring (24) from the piston.



Caution

Using seal kits with incompatible fluid will result in quad ring damage. Refer to Section 7.0.

- 4.4.5 Coat the new quad ring (24) with compatible type of oil, and place it carefully into the piston (8) groove.

- 4.4.6 Make sure quad ring (24) is properly seated in its groove. See Figure 1.

- 4.4.7 Insert the original piston assembly carefully in cylinder bore and over pin (1) retained in cylinder block (11) from previous usage.



Caution

Do not damage lips of quad ring (24). Damage may result in leaks or erratic operation.

- 4.4.8 Apply rubber to iron adhesive such as Eastman 910 or equivalent into the groove in the bore of the cylinder block. Carefully insert the outer diameter of the boot (9) into the groove in the bore of the cylinder block

Note: In older 225DP100 caliper disc brake assembly designs, the cylinder block has a counter bore instead of a groove. When working on these older designs, the boot should be bonded to the counter bore using a good grade of rubber-to-iron adhesive.

225DP100 caliper disc brake assembly

4.4.9 Press the piston into the cylinder block until fully inserted. It may be necessary to loosen the bleed screws (23) as shown in Figure 1 on the cylinder block (11) to bleed off the pressure to fully insert the piston (8).



Caution

Do not damage lips of quad ring (24). Damage may result in leaks or erratic operation.

4.4.10 Install the friction shoe assemblies (7) by sliding the friction shoe assembly over the piston (8), and installing the friction shoe retainer (5).

4.5.9

Apply rubber to iron adhesive such as Eastman 910 or equivalent into the groove in the bore of the cylinder block. Carefully insert the outer diameter of the boot (9) into the groove in the bore of the cylinder block

Note: In older 225DP100 caliper disc brake assembly designs, the cylinder block (11) has a counter bore instead of a groove. When working on these older designs, the boot should be bonded to the counter bore using a good grade of rubber-to-iron adhesive.

4.5 Piston Replacement



Warning

Only qualified maintenance personnel should replace the piston. Faulty workmanship may result in possible personal injury, 225DP100 caliper disc brake assembly malfunction or damage to the machinery.

4.5.10

Press piston (8) into cylinder block (11) until fully inserted. It may be necessary to loosen the bleed screws (23) as shown in Figure 1 on the cylinder block to bleed off the pressure to fully insert the piston.



Caution

Before proceeding, make sure that the correct piston kit is being used for the piston replacement. The quad ring (24) is designed to be used with a particular actuating medium; either air/mineral oil or vegetable base fluid. Proper kit part numbers for the different actuating medium are noted in section 8.2.

4.5.11

Install the friction shoe assemblies (7) by sliding the friction shoe assembly over the piston (8), and installing the friction shoe assembly retainer (5) with the hex head cap screws (23) and lockwashers (25). See Figure 1



Caution

Use only genuine Airflex friction material. Use of non-original Airflex material may result in unpredictable performance.

4.5.12

For fluid actuation bleed the system per Section 4.1.1 – 4.1.5.

4.5.1 The 225DP100 caliper disc brake assembly must be removed from the machinery in order to replace the piston assembly or quad ring.

4.5.2 Remove friction shoe assemblies (7) as explained in section 4.3

4.5.3 Remove the piston (8) and the boot (9). Clean the dust boot grooves in cylinder block (11).



Caution

Keep dust boot groove free of contamination.

4.5.4 Remove the quad ring (24) from the piston.



Caution

Using quad rings or piston kits with incompatible fluid will result in quad ring damage.

4.5.5 Install the new pin (1) and retain with the new snap ring (19) into the cylinder block (11).

4.5.6 Coat the new quad ring (24) with compatible type of oil, and place it carefully into the quad ring groove.

4.5.7 Make sure quad ring (24) is completely seated in its groove.

4.5.8 Insert the new piston assembly carefully in cylinder bore and over pin (1) retained in cylinder block (11).

225DP100 caliper disc brake assembly

5.0 ACCESSORIES

5.1 Pressure Intensifiers – Air over Hydraulic

5.1.1 Description

5.1.1.1 For those installations that require but are not equipped with a high hydraulic pressure power source, a pressure intensifier can be used to provide the required pressure. This device multiplies a low air pressure input into a higher hydraulic pressure output.

5.1.1.2 Airflex supplied pressure intensifiers for the Airflex 225DP100 caliper disc brake assemblies are designed for industrial caliper brakes which require low initial hydraulic displacement prior to full pressure application, and require near zero residual system pressure. They are intended for single stop and low cyclic duty. They multiply a low air pressure input into a higher hydraulic pressure output.

5.1.2 Hydraulic to air pressure Ratio is 15:1

5.1.3 Actuation Fluid

5.1.4 Airflex-supplied intensifiers are compatible with vegetable base hydraulic fluids only.



Caution

Using non-vegetable base hydraulic fluid will result in damage to intensifier.

5.1.5 Intensifier model 153x0772 is designed for use with one 225DP100 caliper disc brake assembly. Intensifier model 153x1135 is designed for use with 2 or more 225DP100 caliper disc brake assemblies to be engaged at the same time.



Warning

Using the incorrect number of 225DP100 caliper disc brake assemblies on a system designed with either the intensifier model 153x0772 which is designed for use with one 225DP100 caliper disc brake assembly or 153x1135 which is designed for use with 2 or more 225DP100 caliper disc brake assemblies engaged at the same time may result in either inadequate performance or damage to the caliper components.

6.0 ORDERING INFORMATION/TECHNICAL ASSISTANCE

6.1 Equipment Reference

6.1.1 In any correspondence regarding Eaton Airflex Equipment, refer to the information on the product nameplate and call or write:

Eaton Corporation
Hydraulics Group USA
Airflex Products
9919 Clinton Road
Cleveland, Ohio 44144
Tel.: (216) 281-2211
Fax: (216) 281-3890

225DP100 caliper disc brake assembly

7.0 PARTS (STANDARD)

7.1 Basic Assemblies

Item	Description	225DP100 Standard Friction Linings /w Veg. Seals 142862H (512123)		225DP100 Standard Friction Linings /w Min. Seals 142862J (512124)		225DP100 Slip Friction Linings /w Veg. Seals 142862W (513215)		225DP100 Slip Friction Linings /w Min. Seals 142862C (512463)	
		Part Number	Quantity	Part Number	Quantity	Part Number	Quantity	Part Number	Quantity
1	Pin	202716	2	202716	2	202716	2	202716	2
2	Sleeve	202717	2	202717	2	202717	2	202717	2
3	Spring Guide	202718	2	202718	2	202718	2	202718	2
4	Washer	202719	2	202719	2	202719	2	202719	2
5	Friction Shoe Retainer	202774	2	202774	2	202774	2	202774	2
7	Friction Shoe Assembly	307541-01	2	307541-01	2	307541-02	2	307541-02	2
8	Piston	303866	2	303866	2	303866	2	303866	2
9	Boot	304485	2	304485	2	304485	2	304485	2
10	Bridge Pipe	407914-02	1	407914-02	1	407914-02	1	407914-02	1
11	Cylinder Block	504813	2	504813	2	504813	2	504813	2
12	Socket Head Screw	000030X0922	2	000030X0922	2	000030X0922	2	000030X0922	2
13	Lockwasher	000031X0007	2	000031X0007	2	000031X0007	2	000031X0007	2
14	Hex Nut (Shipping Purposes Only)	000045X0004	2	000045X0004	2	000045X0004	2	000045X0004	2
15	Spring	000071X0043	2	000071X0043	2	000071X0043	2	000071X0043	2
16	Pipe Plug	000077X0001	2	000077X0001	2	000077X0001	2	000077X0001	2
17	45 Degree Elbow	000091X0002	2	000091X0002	2	000091X0002	2	000091X0002	2
18	Elbow	000092X0002	1	000092X0002	1	000092X0002	1	000092X0002	1
19	Snap Ring	000138X0052	2	000138X0052	2	000138X0052	2	000138X0052	2
20	Snap Ring	000138X0053	2	000138X0053	2	000138X0053	2	000138X0053	2
21	Retaining Ring	000139X0044	4	000139X0044	4	000139X0044	4	000139X0044	4
22	Dyna Seal	000153X0309	4	000153X0309	4	000153X0309	4	000153X0309	4
23	Hex Head Cap Screw	000001X0002	8	000001X0002	8	000001X0002	8	000001X0002	8
24	Quad Ring	000332X0006	2	000332X0007	2	000332X0006	2	000332X0007	2
25	Lockwasher	000068X0001	4	000068X0001	4	000068X0001	4	000068X0001	4

225DP100 caliper disc brake assembly

8.0 KITS

8.1 Seal Kit

Model	Kit P/N	Description	Boot (9)	Quad Ring (24)
225DP100 Vegetable	145862YB	Part No. Quantity	304485 2	000332x0006 2
225DP100 Mineral	1452862XB	Part No. Quantity	304485 2	000332x0007 2

8.2 Piston Replacement Kit

Model	Kit P/N	Description	Pin (1)	Sleeve (2)	Spring Guide (3)	Washer (4)	Piston (8)	Boot (9)	Spring (15)	Snap Ring (19)	Snap Ring (20)	Retaining Ring (21)	Quad Ring (24)
225DP100	145682X	Part No. Quantity	202617 1	202717 1	202718 1	202719 1	303866 1	304485 1	000071X0043 1	000138X0052 1	000138X0053 1	000139X0044 2	000332X0007 1
225DP100	145682Y	Part No. Quantity	202617 1	202717 1	202718 1	202719 1	303866 1	304485 1	000071X0043 1	000138X0052 1	000138X0053 1	000139X0044 2	000332X0006 1

Note: Items 2 ,3, 4, 8, 9, 15, 20, 24 come as a complete assembly

8.3 Friction Shoe Assemblies

Model	Description	Friction Shoe Assembly
225DP100 Standard Friction Linings	Part No. Quantity	307541-01 2
225DP100 Slip Friction Linings	Part No. Quantity	307541-02 2

Eaton
Hydraulics Group USA
Airflex Division
9919 Clinton Road
Cleveland, OH 44144-1077
Tel: 216-281-2211
Fax: 216-281-3890

Eaton
Hydraulics Group Asia Pacific
Airflex Division
281 Fa Sai Road
Waigaoqiao Free Trade Zone
Shanghai 200131
China
Tel:(+8621) 5048-4811
Fax:(+8621) 5048-4911