

RS 9070

 **Warning**

Forward this manual to the person responsible for Installation, Operation and Maintenance of the product described herein. Without access to this information, faulty Installation, Operation or Maintenance may result in personal injury or equipment damage.

Installation, Operation and Maintenance of the Airflex[®] Model BT Rotorseal Assembly



 **Caution:**

Use Only Genuine Airflex[®] Replacement Parts

The Airflex Division of Eaton Corporation recommends the use of genuine Airflex replacement parts. The use of non-genuine Airflex replacement parts could result in substandard product performance, and may void your Eaton warranty. For optimum performance, contact Airflex:

In the U.S.A. and Canada: **(800) 233-5890**
Outside the U.S.A. and Canada: **(216) 281-2211**

June, 1972 PDF Format

EAT•N

COMPONENT PARTS FOR AIRFLEX TYPE BT ROTOSEAL P/N 145579 N

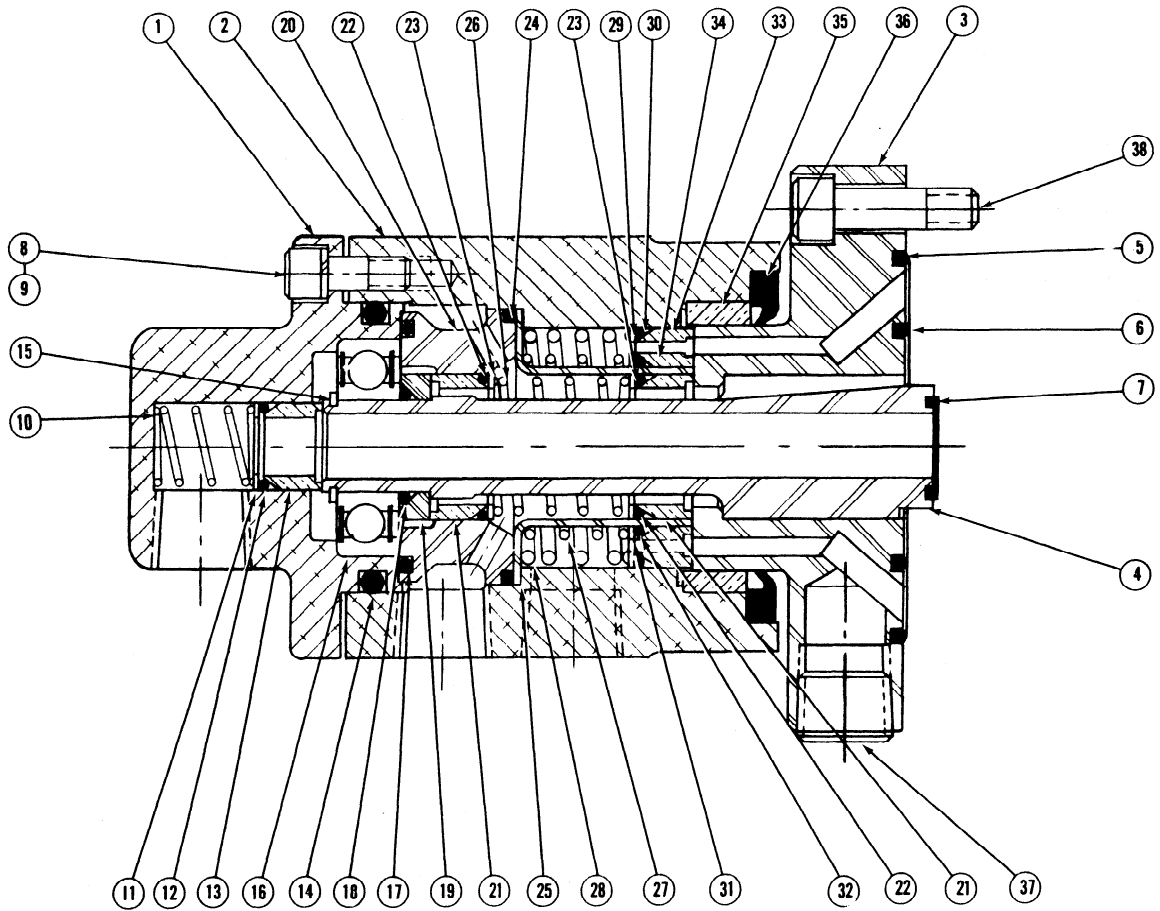

ITEM	DESCRIPTION	PART NO.	QTY.	ITEM	DESCRIPTION	PART NO.	QTY.
1	Rear Housing	301453	1	20	Seal Support	200235	1
2	Front Housing	301452	1	21	Inner Seal Ring	200238	2
†3	Outer Shaft	508375-2	1	22	"O" Ring	73x217	2
†4	Inner Shaft	508375-3	1	23	Inner Washer	200241	2
* 5	Seal	350x7	1	24	"O" Ring	73x218	1
* 6	Seal	350x5	1	25	Sleeve	300231	1
* 7	Seal	350x1	1	26	Inner Spring	200244	1
8	Socket Head Cap Screw	30x104	6	27	Intermediate Spring	200245	1
9	Lockwasher	31x1	6	28	Outer Spring	200246	1
10	Rear Seal Spring	200156	1	* 29	Outer Washer	200243	1
* 11	Rear Seal Spring Retainer	200157	1	30	"O" Ring	73x219	1
* 12	"O" Ring	73x214	1	31	Intermediate Washer	200242	1
* 13	Rear Carbon Seal	200155	1	* 32	"O" Ring	73x220	1
14	"O" Ring	73x100	1	33	Outer Seal Ring	200240	1
15	Snap Ring	200158	1	* 34	Intermediate Seal Ring	200239	1
16	Ball Bearing	159x57	1	35	Bronze Bearing	202968	1
* 17	"O" Ring	73x215	1	36	Shaft Oil Seal	113x381	1
* 18	"O" Ring	73x216	1	37	Pipe Plug	77x3	1
19	Seal Ring	200386	1	38	Socket Head Cap Screw	30x208	4

* These parts are furnished in Rotorseal Replacement Kit. Part No. 145579Z.

† Available as assembly. Part No. 508375-1.

I. OPERATION

A. DESCRIPTION

The Airflex triple passage rotor seal is a reliable means for simultaneously introducing air under pressure to three rotating members on the same shaft. The rotor seal operates continuously or intermittently at high speeds in either direction.

The type "BT" rotor seal has a mounting flange to simplify installation on the machinery shaft or assembly.

Three female 1/2" pipe threaded inlets on the rotor seal body provide access to the three concentric passages. All three passages can discharge directly into the rotating shaft. A female pipe threaded opening through the rotor seal flange can be used as an optional outlet for the outermost passage.

Consult the factory, when contemplating the use of Airflex rotor seals with mediums other than air.

II. INSTALLATION

A. MOUNTING

The Airflex type "BT" rotor seal has been designed for flange mounting to the machinery shaft or assembly.

1. The mating surfaces must be free from dirt, knicks, etc., and the shaft face must be at right angles to the shaft O.D. within .003 T.I.R.
2. Be sure the three quad rings (5), (6) and (7) are properly seated in the rotor seal flange grooves before mounting.
3. Torque mounting screws to 55#Ft.

B. AIR CONNECTIONS

The rotor seal body has three 1/2" female pipe threaded inlets for the inlet air connection. The connection to the rotor seal should always be through flexible hoses and the air supply piping should be self-supporting. Rigid air connections will tend to preload the rotor seal bearings. A good pipe thread sealant should be used when connecting flexible hoses to the rotor seal.

III. MAINTENANCE

Airflex rotor seals are manufactured of quality materials to precision tolerances. These instructions should be followed carefully to assure a properly repaired rotor seal. Repairs should be made only in clean, dust-free surroundings.

A. DISASSEMBLY

1. Remove the six socket head cap screws (8) and lockwashers (9) from rear housing (1). Insert a screwdriver into gap between rear housing and front housing and carefully pry apart. Work around the circumference of the rotor seal to avoid cocking. When internal parts do not fall free from rear housing (1), the aid of a wire hook may be required to remove same.
2. To disassemble front housing, remove snap ring (15). Insert a large screwdriver or similar tool between front housing (2) and outer shaft flange (3). Pry apart by working around the circumference of the rotor seal to avoid cocking. When the bearing (16) comes off the inner shaft (4) the bearing can be removed. The front housing (2) and outer shaft flange (4) can now be removed from the front housing. Spring retainer (25) is press fitted into front housing and must be pressed out. The bronze bearing (35) and shaft oil seal (36) should only be removed if damaged or severely contaminated.

B. CLEANING AND INSPECTION

1. Clean and inspect all parts removed and disassembled. Any commercial cleaning solvent is suitable for this purpose.

2. Inspect and check the ball bearing (16). It should be free of rust and contamination, revolve smoothly without binding, and show no signs of excessive play or wear.
3. Inspect lapped sealing end of inner shaft (4) and outer shaft (3). The lapped surfaces must be free of scoring and excessive wear. If they are in poor condition, the parts should be replaced. The inner and outer shafts are press fitted together, if only one needs to be replaced, they must be pressed apart. Bearing and shafts can be obtained from the factory.

C. ASSEMBLY

Front housing assembly-NOTE: Apply a good "O" Ring Lube to "O" Rings before assembly. Assemble bronze bearing (35) and shaft oil seal (36) into front housing (2). Be sure that oil seal lip is facing inward. Install shaft assembly, center shaft (3) and inner shaft (4) into front housing. Place this assembly on a work bench, flange down. In this position the following parts should be assembled as shown in illustration.

Outer seal ring (33), "O" ring (30), outer washer (29), intermediate seal ring (34), "O" ring (32), intermediate washer (31), outer spring (28), intermediate spring (27), spring retainer (25), inner seal ring (21), "O" ring (22), inner washer (23), inner spring (26), "O" ring (24) and "O" ring (17) should be installed on seal support (20). Install seal support into front housing and follow with inner washer (23), "O" ring (22), inner seal ring (21), seal ring (19), "O" ring (18), ball bearing (16), snap ring (15).

When snap ring is in place this partial assembly should be checked for smooth operation.

Rear housing assembly-Assemble rear seal spring (10), rear seal spring retainer (11), "O" ring (12), and rear carbon seal (13) into rear housing. Assemble front and rear housing. This should be done with lapped faces of carbon facing upward to prevent internal parts from dropping out of position. Place air inlet holes in desired position. Fasten housing with socket head cap screws (8) and lockwashers (9). Tighten screws securely to equal tension. Check for smooth operation.

D. AIRFLEX FACTORY REPAIR

A complete factory exchange and rebuilding service with guarantee of satisfactory operation is available at nominal charge. Write for return material authorization (RMA) number before sending rotor seal to factory.

For additional information, contact Eaton Corporation, Industrial Drives Division. In any correspondence regarding Airflex equipment refer to the size shown on the housing.

Call or write Eaton Corporation, Industrial Drives Division, 9919 Clinton Road, Cleveland, Ohio, 44144.

EATON PRODUCT WARRANTY

Subject to the conditions stated herein, Eaton Corporation warrants to the Purchaser that each new Airflex Product manufactured by Eaton will be free from failures caused by defects in material and workmanship, and will deliver its rated capacity, for a period of twelve (12) months from the date of shipment to Purchaser, provided such Product is properly installed, properly maintained, operated under normal conditions and with competent supervision. Warranty claims shall be made in writing and the part or parts shall, if requested by Airflex Division, be returned prepaid to the Airflex Division for inspection. Upon a determination that a defect exists, Eaton shall thereupon correct any defect, at its option either by repairing any defective part or parts or by making available at Eaton's plant a repaired or replacement part. This warranty does not extend to normal wear parts or components of the Product, such as friction material and friction surfaces.

LIMITATION OF WARRANTY

THE FOREGOING WARRANTY IS EXCLUSIVE AND IN LIEU OF ALL OTHER WARRANTIES WHETHER WRITTEN, ORAL OR IMPLIED. ANY IMPLIED WARRANTY OF MERCHANTABILITY OR FITNESS FOR A PARTICULAR PURPOSE ARE SPECIFICALLY EXCLUDED.

In no event shall Eaton be liable for special, incidental or consequential damages. Eaton's liability arising out of the supplying of such Product, or its use, whether in warranty, contract or otherwise, shall in no case exceed the cost of correcting defects in the Products as herein provided. Upon expiration of the twelve (12) month period, all such liability shall terminate. THE FOREGOING SHALL CONSTITUTE THE SOLE REMEDY OF PURCHASER AND THE SOLE LIABILITY OF EATON.