

High speed low inertia



Overview

With decades of experience and success in power transmission Eaton Airflex® has introduced its latest addition to its robust portfolio of industrial clutches and brakes.

The Airflex Pneumatic Disc Clutch (PDC) provides a durable, trouble-free design to maximize uptime at a fraction of the cost of common disc clutches.

The Airflex Pneumatic Disc Clutch (PDC) is the perfect choice for new installations and aftermarket upgrades. Clutch life is extended through lower friction wear and reduced heat generation compared to the competition.

The PDC utilizes a simple air-tube design to provide consistent pressure during actuation while boasting smooth engagement and disengagement, low inertia, easy maintenance and high torque capabilities.

Application

- Draw works
- Offshore deck equipment
- Marine drives/ Dredging
- Pipe-laying Vessel
- Processing & Aggregates
- Recycling/ Shredding
- Logging Equipment

Features

- Rated for up to 850,000 lb-in of torque
- Low Inertia friction disc assembly
- Low friction wear
- Reduced heat generation
- Backed by Eaton's 2 year warranty

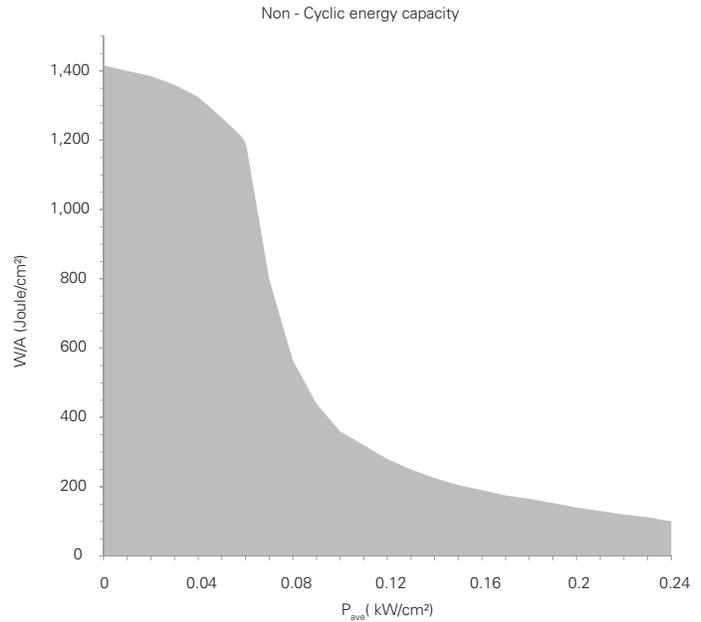
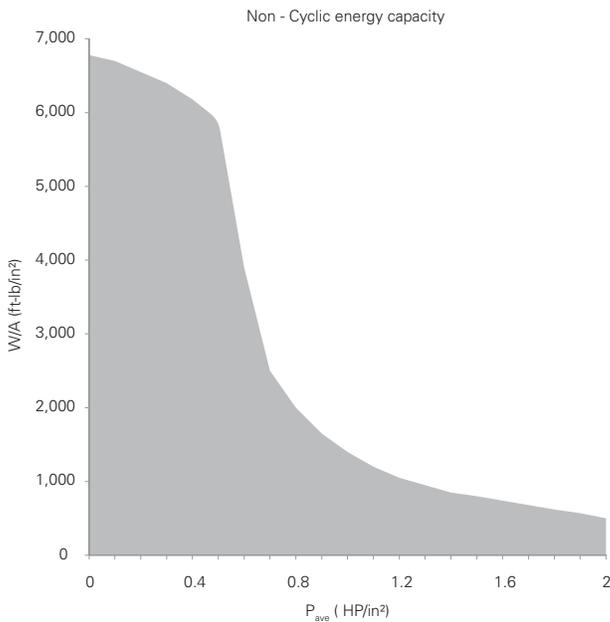

PDC Component parts

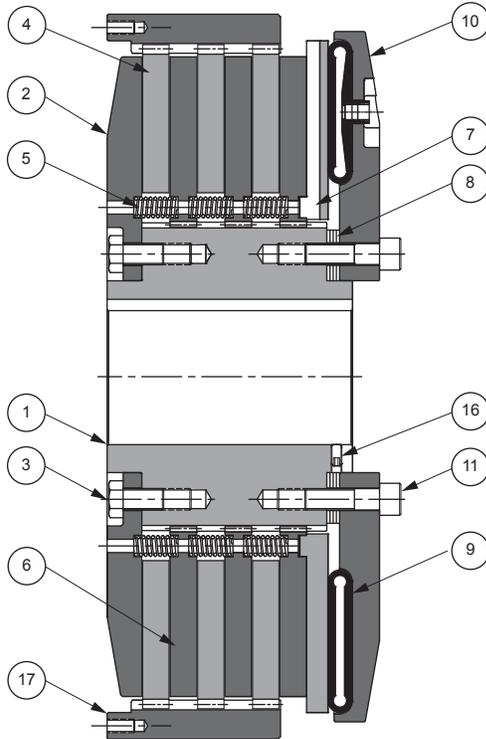

Item number	Description
1	Hub
2	Back plate
3	Hex head cap screw
4	Friction disc
5	Release spring
6	Center plate
7	Pressure plate
8	Shim
9	Air tube
10	Tube holding plate
11	Socket head cap screw
16	Set screw
17	Driving ring

English

Size	① Element PN	Driving ring PN	② ③ Dynamic torque lb.in @100 psi	Maximum speed rpm	④ Total weight lb	⑤ Total inertia lb.ft ²	Driving ring & friction disc weight lb	Driving ring & friction disc inertia lb.ft ²	Bore range		Lining area in ²
									Minimum in	Maximum in	
118PDC	146597A	515860	65,000	1750	287	106	50	33	2.69	3.88	308
218PDC	146598A	515861	130,000	1750	395	158	104	70	3.38	3.88	616
318PDC	146599A	515862	195,000	1750	481	196	136	91	3.88	3.88	924
124PDC	146600A	515863	138,000	1350	578	357	105	117	3.38	5.00	541
224PDC	146601A	515864	276,000	1350	770	506	189	209	4.25	5.00	1,082
324PDC	146602A	515865	414,000	1350	930	608	232	251	4.75	5.00	1,623
327PDC	146604A	515867	476,000	1200	1195	915	298	396	5.13	7.00	1,907
230PDC	146605A	515868	562,000	1100	1364	1290	306	490	5.63	7.00	1,791
330PDC	146606A	515869	843,000	1100	1725	1691	448	713	6.38	7.00	2,686

SI

Size	① Element PN	Driving ring PN	② ③ Dynamic torque Nm@6.9 bar	Maximum speed rpm	④ Total weight kg	⑤ Total inertia kg.m ²	Driving ring & friction disc weight kg	Driving ring & friction disc inertia kg.m ²	Bore range		Lining area mm ²
									Minimum mm	Maximum mm	
118PDC	146597A	515860	7,345	1750	130	4.5	23	1.4	68.3	98.4	198,709
218PDC	146598A	515861	14,689	1750	179	6.7	47	2.9	85.7	98.4	397,419
318PDC	146599A	515862	22,034	1750	218	8.3	62	3.8	98.4	98.4	596,128
124PDC	146600A	515863	15,593	1350	262	15.0	48	4.9	85.7	127.0	349,032
224PDC	146601A	515864	31,186	1350	349	21.3	86	8.8	108.0	127.0	698,063
324PDC	146602A	515865	46,780	1350	422	25.6	105	10.6	120.7	127.0	1,047,095
327PDC	146604A	515867	53,785	1200	542	38.6	135	16.7	130.2	177.8	1,230,320
230PDC	146605A	515868	63,503	1100	619	54.4	139	20.6	142.9	177.8	1,155,482
330PDC	146606A	515869	95,254	1100	782	71.3	203	30.0	161.9	177.8	1,732,900

① Basic part only. Does not include driving ring. Driving ring must be ordered separately. Specify bore and key sizes when ordering.

② Dynamic torque shown. Static torque approximately 25% higher.

③ Maximum clutch pressure is 100 psi (6.9 bar)

④ Total weight includes element and driving ring

⑤ Total inertia includes element & driving ring

PDC Dimension data

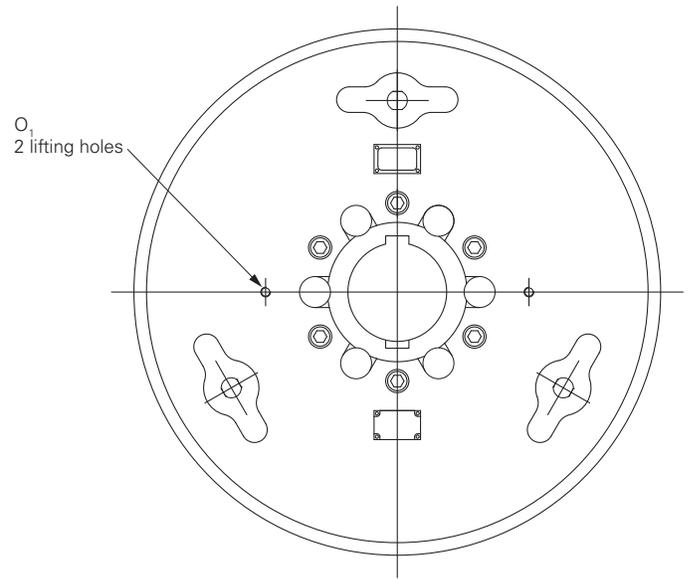
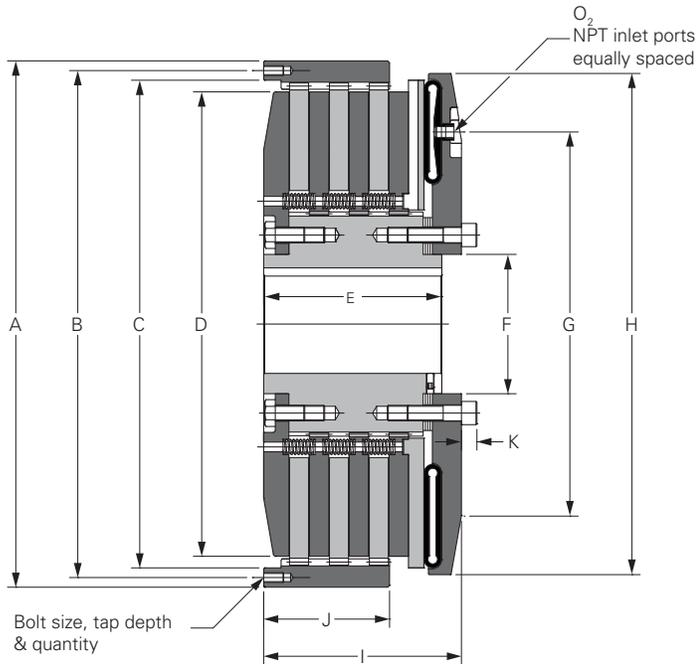

Size	O ₁ [Ⓔ] Size	O ₂ No	O ₂ size
18PDC	1/2-13	3	1/2
24PDC	1/2-13	3	1/2
27PDC	5/8-11	3	1/2
30PDC	5/8-11	4	1/2

English

Size	A	B	C ^{+0.003 -0.000}	D	E	F	G	H	I	J	K	[Ⓔ] Bolt size Tap depth Quantity		
												in	in	in
118PDC	22	20.75	19.500	18.0	4.75	5.25	16.00	21.31	5.62	1.94	0.63	5/8-11	1.25	6
218PDC	22	20.75	19.500	18.0	6.25	5.25	16.00	21.31	7.16	3.50	0.63	5/8-11	1.25	6
318PDC	22	20.75	19.500	18.0	7.75	5.25	16.00	21.31	8.70	5.13	0.63	5/8-11	1.25	6
124PDC	28	26.75	25.500	24.0	5.88	7.00	21.00	27.00	6.62	2.81	1.00	5/8-11	1.25	6
224PDC	28	26.75	25.500	24.0	7.25	7.00	21.00	27.00	8.55	4.50	1.00	5/8-11	1.25	6
324PDC	28	26.75	25.500	24.0	9.38	7.00	21.00	27.00	10.46	6.25	1.00	5/8-11	1.25	6
327PDC	31	29.75	28.500	27.0	9.75	9.00	21.00	27.00	10.72	6.50	1.00	5/8-11	1.25	12
230PDC	34	32.75	31.500	30.0	8.88	9.00	24.75	32.38	10.19	5.63	1.00	5/8-11	1.25	12
330PDC	34	32.75	31.500	30.0	11.50	9.00	24.75	32.38	12.77	8.13	1.00	5/8-11	1.25	12

SI

Size	A	B	C ^{+0.076 -0.000}	D	E	F	G	H	I	J	K	[Ⓔ] Bolt size Tap depth Quantity		
												mm	mm	mm
118PDC	559	527.1	495.30	457.2	120.7	133.4	406.4	541.3	142.7	49.2	16.0	5/8-11	31.8	6
218PDC	559	527.1	495.30	457.2	158.8	133.4	406.4	541.3	181.9	88.9	16.0	5/8-11	31.8	6
318PDC	559	527.1	495.30	457.2	196.9	133.4	406.4	541.3	221.0	130.2	16.0	5/8-11	31.8	6
124PDC	711	679.5	647.70	609.6	149.2	177.8	533.4	685.8	168.1	71.4	25.4	5/8-11	31.8	6
224PDC	711	679.5	647.70	609.6	184.2	177.8	533.4	685.8	217.2	114.3	25.4	5/8-11	31.8	6
324PDC	711	679.5	647.70	609.6	238.1	177.8	533.4	685.8	265.7	158.8	25.4	5/8-11	31.8	6
327PDC	787	755.7	723.90	685.8	247.7	228.6	533.4	685.8	272.3	165.1	25.4	5/8-11	31.8	12
230PDC	864	831.9	800.10	762.0	225.6	228.6	628.7	822.5	258.8	143.0	25.4	5/8-11	31.8	12
330PDC	864	831.9	800.10	762.0	292.1	228.6	628.7	822.5	324.4	206.5	25.4	5/8-11	31.8	12

[Ⓔ] American National standard for unified screw threads

PDC Accessories spider

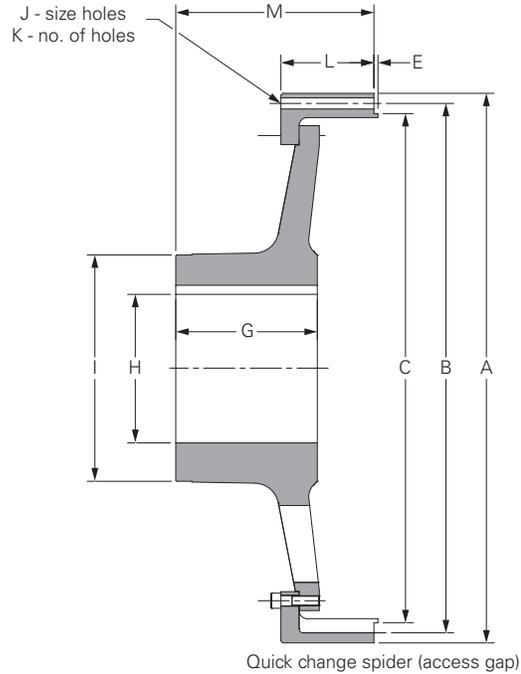
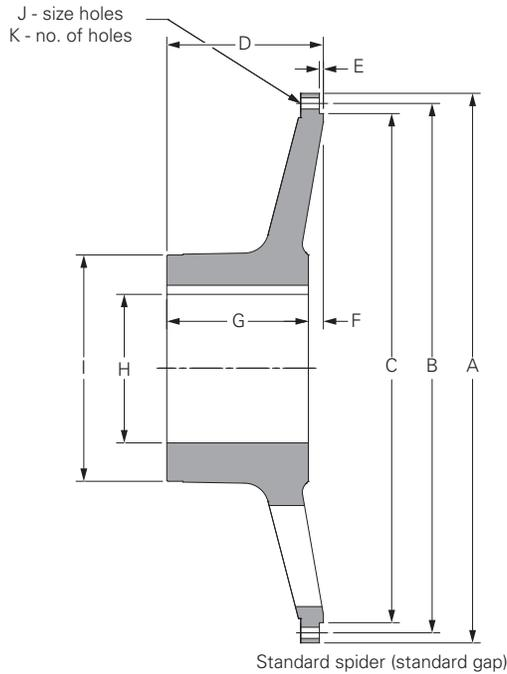

English

Size	A	B	$\begin{matrix} +.003 \\ -.000 \\ C \end{matrix}$	D	E	F	G	I	J	K	L	M
	in	in	in	in	in	in	in	in	in	in	in	in
18PDC	22	20.75	19.496	6.75	0.25	1.00	5.75	8.0	0.688	6	3.50	7.88
24PDC	28	26.75	25.495	8.31	0.25	1.00	7.31	10.0	0.688	6	5.50	10.69
27PDC	31	29.75	28.495	8.75	0.25	1.00	7.75	11.0	0.688	12	4.63	10.19
30PDC	34	32.75	31.495	9.75	0.25	1.00	8.75	14.0	0.688	12	5.75	12.25

SI

Size	A	B	$\begin{matrix} +0.076 \\ 0.00 \\ C \end{matrix}$	D	E	F	G	I	J	K	L	M
	mm	mm	mm	mm	mm	mm	mm	mm	mm	mm	mm	mm
18PDC	558.8	527.1	495.20	171.5	6.4	25.4	146.1	203.2	17.5	152.4	88.9	200.0
24PDC	711.2	679.5	647.57	211.1	6.4	25.4	185.7	254.0	17.5	152.4	139.7	271.5
27PDC	787.4	755.7	723.77	222.3	6.4	25.4	196.9	279.4	17.5	304.8	117.6	258.8
30PDC	863.6	831.9	799.97	247.7	6.4	25.4	222.3	355.6	17.5	304.8	146.1	311.2

English

Size	Standard Spider			Quick change spider			Bore range (Rectangular key)	
	PN	Weight at min bore lb	Inertia at min bore lb-ft ²	PN	Weight at min bore lb	Inertia at min bore lb-ft ²	H min in	H max in
118PDC		123	29		164	57	2.88	6.38
218PDC	515989	117	29	515996	158	57	3.63	5.88
318PDC		113	29		153	56	4.13	5.25
124PDC		234	92		319	174	3.38	7.75
224PDC	515991	222	92	515997	302	174	4.75	7.00
324PDC		213	91		293	173	5.38	6.50
327PDC	515993	284	141	515998	361	271	5.63	7.25
230PDC	515995	481	260	515999	598	476	5.88	10.38
330PDC		462	256		591	497	6.75	9.50

PDC Shaft to shaft gaps

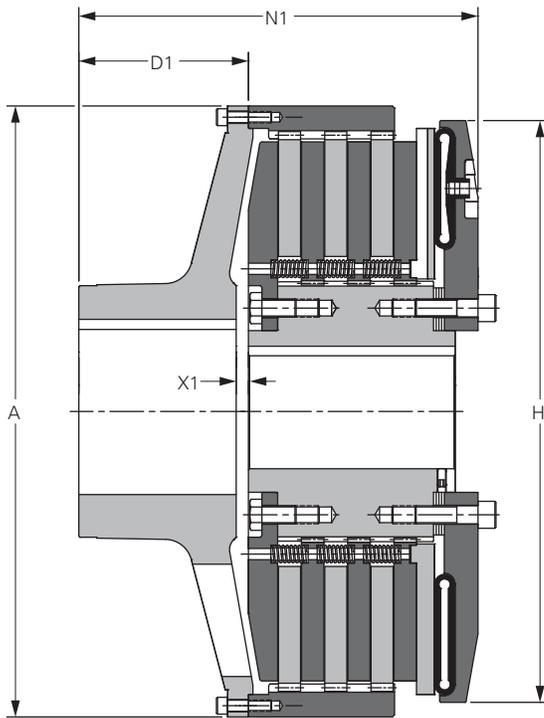

Standard spider (Standard gap)

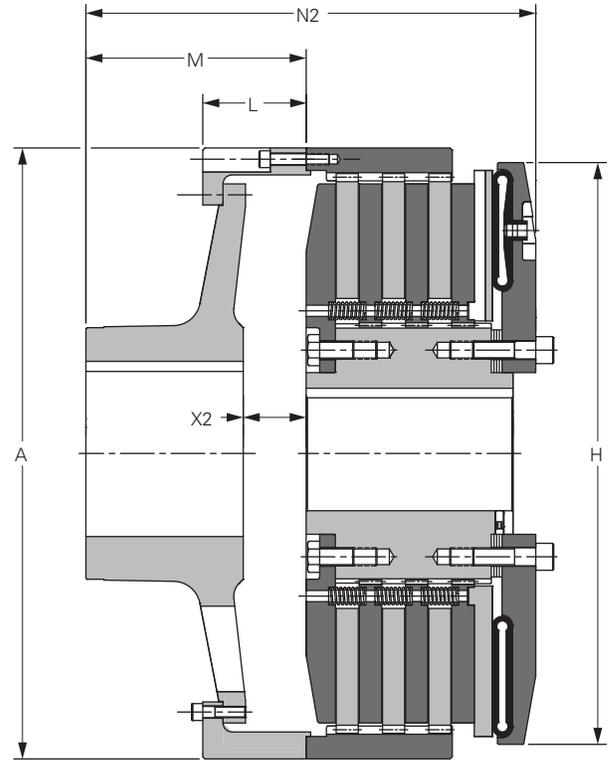

Quick change spider (Access gap)

English

Size	A	D1	H	L	M	N ₁	N ₂	X1	X2
	in	in	in	in	in	in	in	in	in
118PDC	22	6.50	21.31	3.50	7.88	12.12	13.50	0.75	2.13
218PDC	22	6.50	21.31	3.50	7.88	13.66	15.04	0.75	2.13
318PDC	22	6.50	21.31	3.50	7.88	15.20	16.58	0.75	2.13
124PDC	28	8.06	27.00	5.50	10.69	14.68	17.31	0.75	3.38
224PDC	28	8.06	27.00	5.50	10.69	16.61	19.24	0.75	3.38
324PDC	28	8.06	27.00	5.50	10.69	18.52	21.15	0.75	3.38
327PDC	31	8.50	27.00	4.63	10.19	19.22	20.91	0.75	2.44
230PDC	34	9.50	32.38	5.75	12.25	19.69	22.44	0.75	3.50
330PDC	34	9.50	32.38	5.75	12.25	22.27	25.02	0.75	3.50

SI

Size	A	D1	H	L	M	N ₁	N ₂	X1	X2
	mm	mm	mm	mm	mm	mm	mm	mm	mm
118PDC	559	165.1	541.3	88.9	200.2	307.8	342.9	19.1	54.1
218PDC	559	165.1	541.3	88.9	200.2	347.0	382.0	19.1	54.1
318PDC	559	165.1	541.3	88.9	200.2	386.1	421.1	19.1	54.1
124PDC	711	204.7	685.8	139.7	271.5	372.9	439.7	19.1	85.9
224PDC	711	204.7	685.8	139.7	271.5	421.9	488.7	19.1	85.9
324PDC	711	204.7	685.8	139.7	271.5	470.4	537.2	19.1	85.9
327PDC	787	215.9	685.8	117.6	258.8	488.2	531.1	19.1	62.0
230PDC	864	241.3	822.5	146.1	311.2	500.1	570.0	19.1	88.9
330PDC	864	241.3	822.5	146.1	311.2	565.7	635.5	19.1	88.9

Eaton
Hydraulics Group USA
Airflex Division
9919 Clinton Road
Cleveland, OH 44144-1077
Tel: 216-281-2211
Fax: 216-281-3890

Eaton
Hydraulics Group Asia Pacific
Airflex Division
281 Fa Sai Road
Waigaoqiao Free Trade Zone
Shanghai 200131
China
Tel:(+8621) 5048-4811
Fax:(+8621) 5048-4911