

DBA 8080RM

Installation, Operation and Maintenance of the Airflex[®] DBAT Brake Assembly

Warning

Forward this manual to the person responsible for Installation, Operation and Maintenance of the product described herein. Without access to this information, faulty Installation, Operation or Maintenance may result in personal injury or equipment damage.

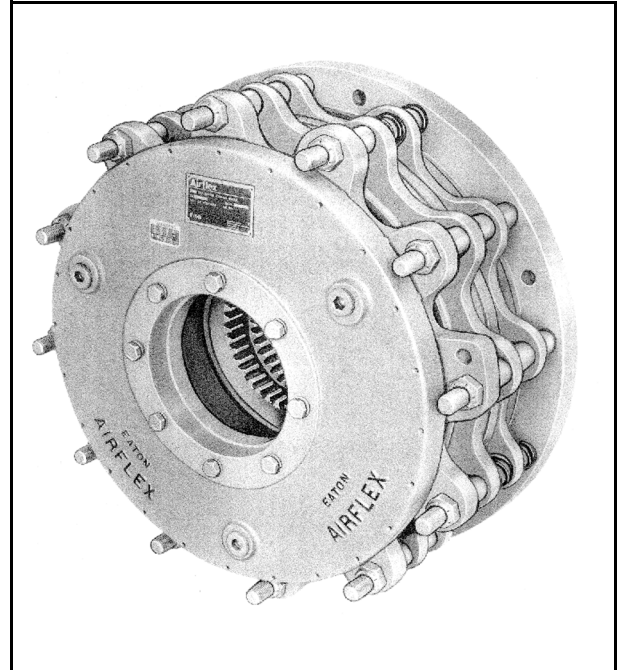

Caution

Use Only Genuine Airflex[®] Replacement Parts.
The Airflex Division of Eaton Corporation recommends the use of genuine Airflex replacement parts. The use of non-genuine Airflex replacement parts could result in substandard product performance, and may void your Eaton warranty. For optimum performance, contact Airflex:

In the U.S.A. and Canada: **(800) 233-5926**
Outside the U.S.A. & Canada: **(216) 281-2211**
Internet: www.airflex.com

November, 1986

(Revised: December, 2007)

203985

©Copyright Eaton Corp., 2008. All rights reserved.

Table of Contents

1.0	INTRODUCTION	5
1.1	Description	5
1.2	How it Works	5
2.0	INSTALLATION	5
2.1	Removal of Existing Clamshell Brake	6
2.2	Disassembly of the 229DBAT Brake	6
2.3	Installation of the 229DBAT Brake	6
2.4	Installation of the Clutch Quick Release Valves	7
3.0	OPERATION	8
4.0	MAINTENANCE	8
4.1	Wear Adjustment:	8
4.2	Replacement of Friction Discs (5)	9
4.3	Replacement of the Diaphragm (11)	9
4.4	Replacement of Springs (19) (20)	10
5.0	ORDERING INFORMATION/TECHNICAL ASSISTANCE	11
5.1	Equipment Reference	11

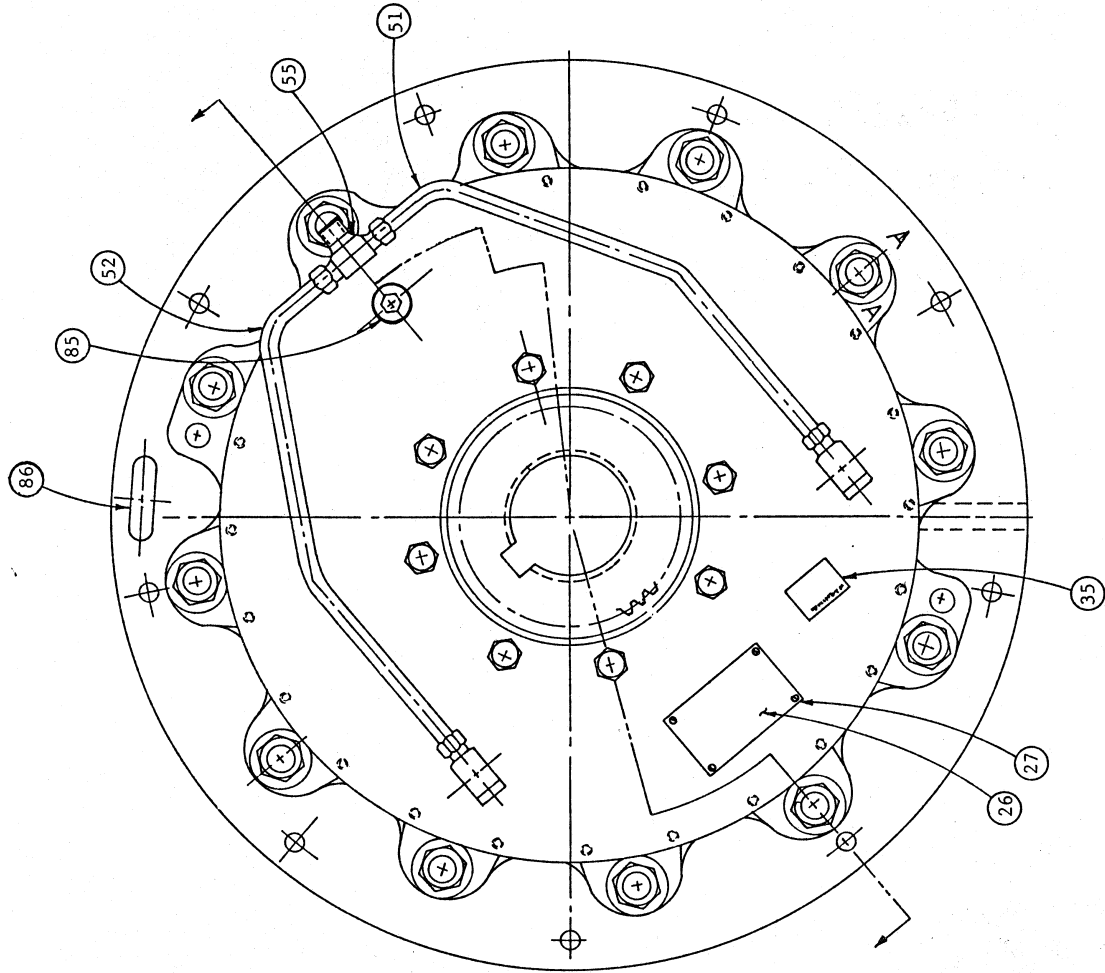
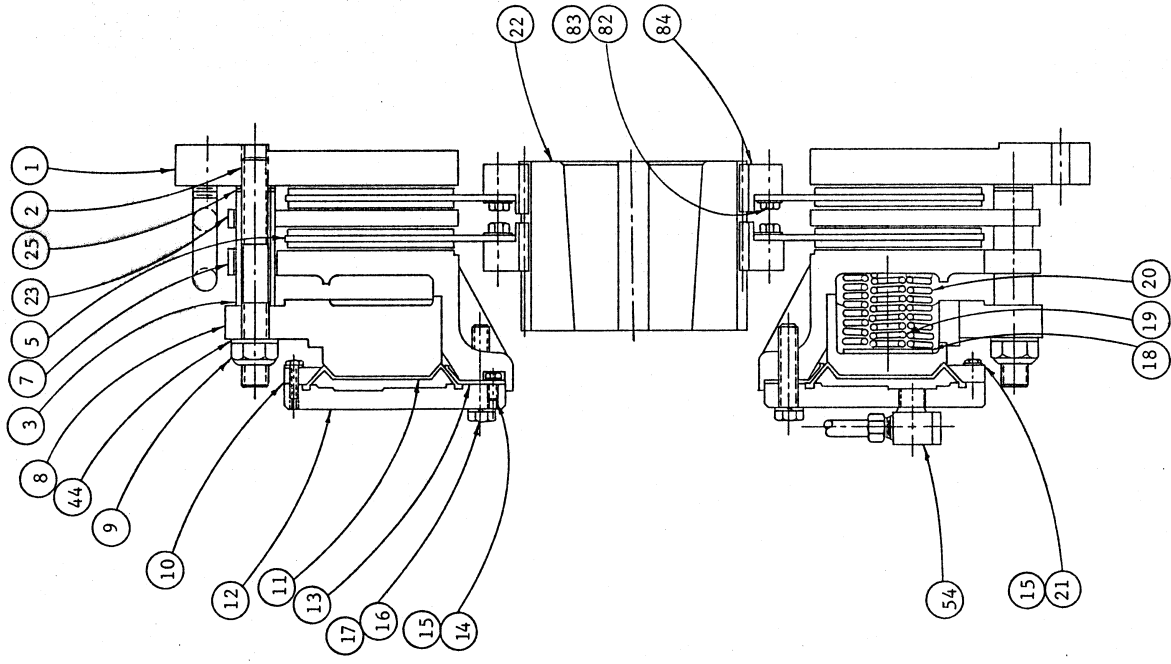

Figure 1

TABLE 1
229DBAT Brake Assembly - 146163DE (Ref. Figure 1)

Item	Description	Part No.	Qty.
1	Mounting Flange	414758	1
2	Stud	307261-01	12
3	Clamp Tube	306542-09	12
5	Friction Disc Sub-Assembly	414753	2
7	Pressure Plate	511916	1
8	Spring Housing	510616	1
9	Locknut	000110X0073	12
10	Outer Clamp Ring	414922	8
11	Diaphragm	407517-02	1
12	End Plate	414754	1
13	Inner Clamp Ring	407684-02	1
14	Hex Head Screw	000001X0205	4
15	Lockwasher	000068X0007	4
16	Hex Head Screw	203806	8
17	Lockwasher	000068X0025	8
18	Spring Retainer Plate	413583	24
19	Inner Spring	304668-02	24
20	Outer Spring	304668-01	24
21	Hex Head Screw	000001X0209	24
22	Gear	414756-02	*
23	Reaction Plate	414757	1
25	Wear Spacer	203973	24
26	Name Plate	306626-10	1
27	Round Head Drive Screw	000153X0644	4
35	Warning Plate	203627	1
44	Flat Washer	000153X0641	12
51	Air Tube	511903	2
52	Air Tube	511903	2
54	Quick Release Valve	145141DE	2
55	Tee	000095X0008	1
82	Hex Head Screw	000197X0607	36
83	Flat Washer	000067X0007	36
84	Ring Gear	414755	2
85	Pipe Plug	000077X0008	1
86	Eye Bolt	000039X0003	1
92	Flat Washer	000067X0003	24
73	Quick Release Valve (Ref. Fig. 2) for clutch	145407DE	4

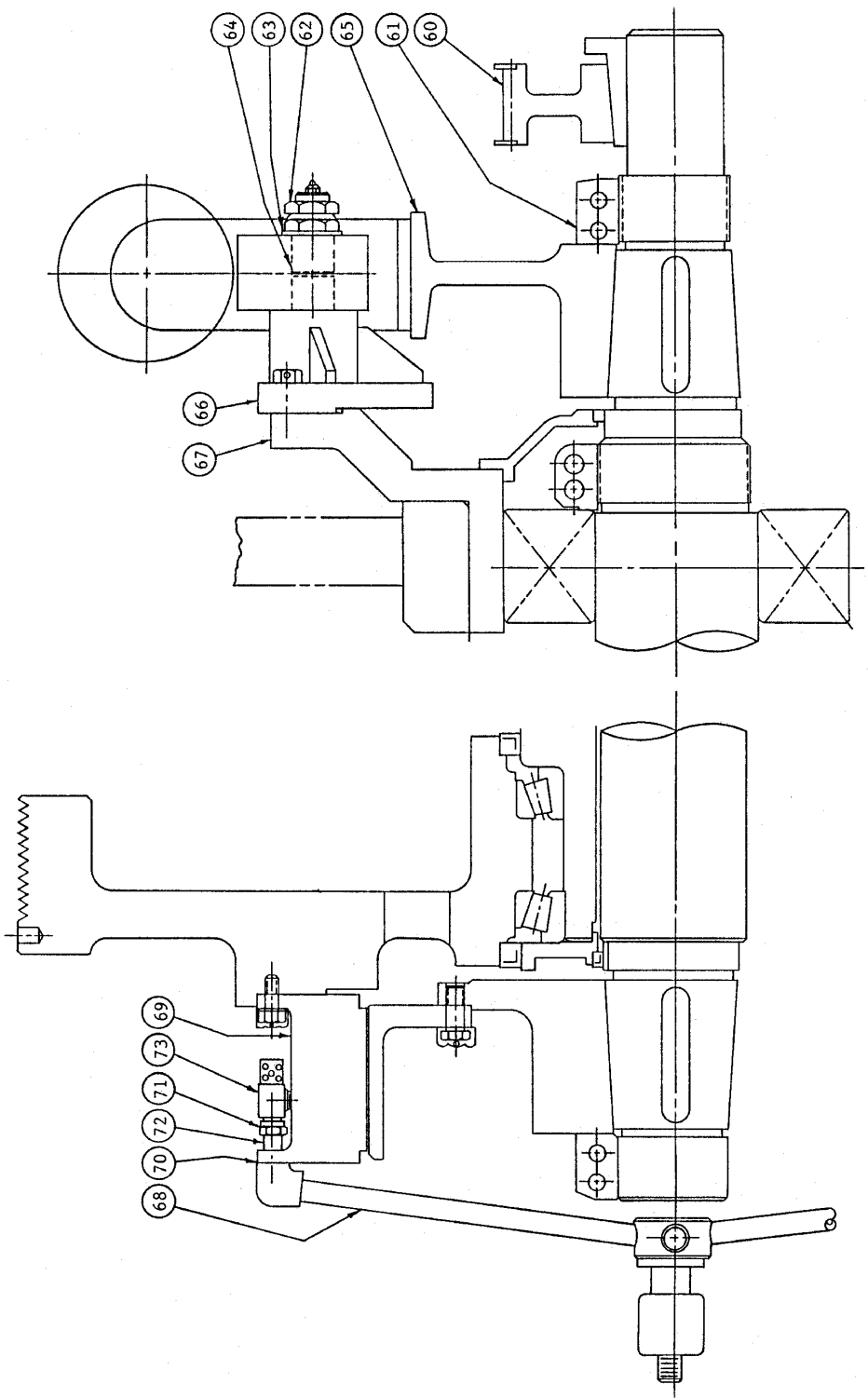

Figure 2

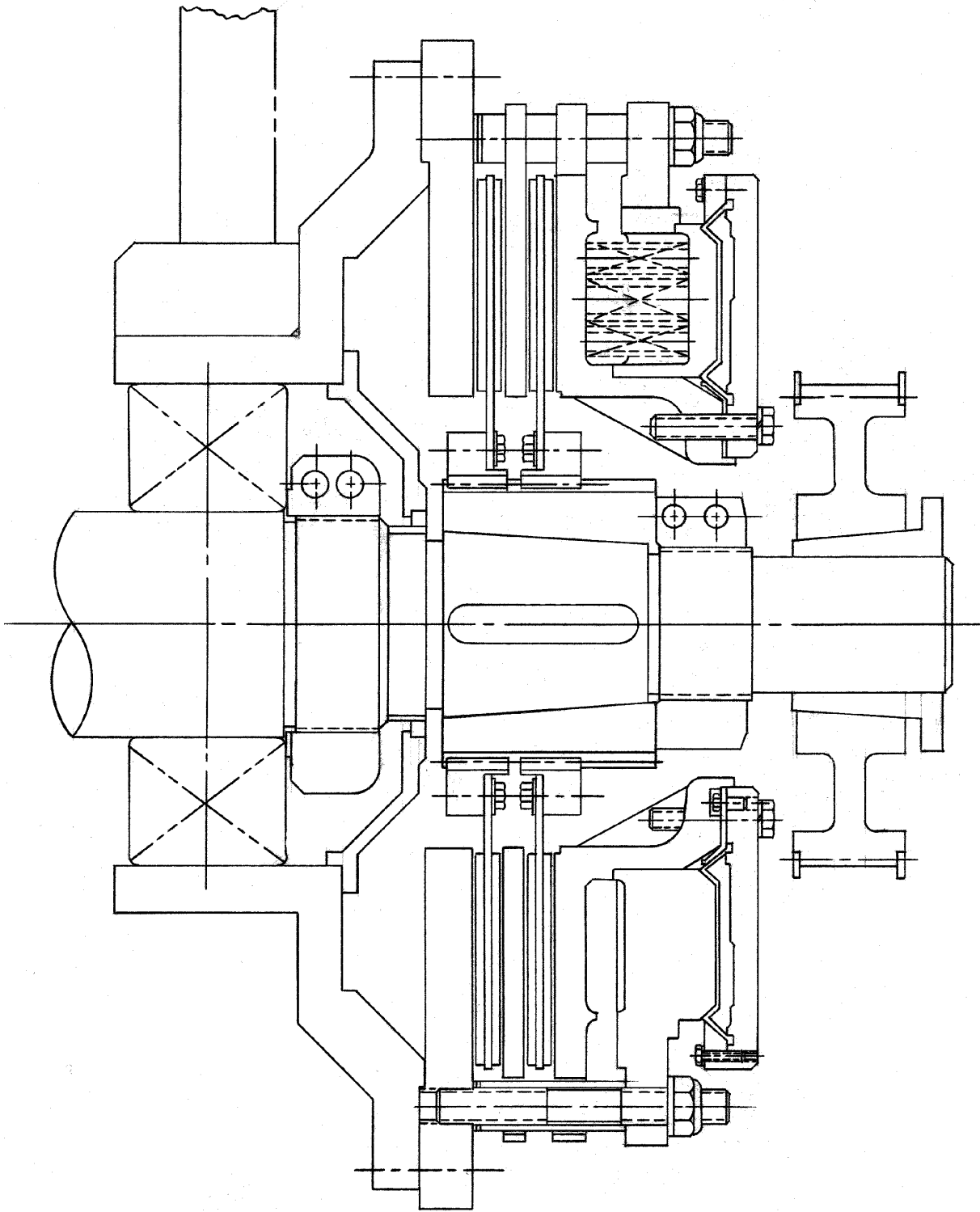



Figure 3

1.0 INTRODUCTION

Throughout this manual there are a number of **HAZARD WARNINGS** that must be read and adhered to in order to prevent possible personal injury and/or damage to equipment. Three signal words “**DANGER**”, “**WARNING**” and “**CAUTION**” are used to indicate the severity of a hazard, and are preceded by the safety alert symbol 

Danger

Denotes the most serious hazard, and is used when serious injury or death **WILL** result from misuse or failure to follow specific instructions.

Warning

Used when serious injury or death **MAY** result from misuse or failure to follow specific instructions.

Caution

Used when injury or equipment damage may result from misuse or failure to follow specific instructions.

It is the responsibility and duty of all personnel involved in the installation, operation and maintenance of the equipment on which this device is used to fully understand the:

Danger

Warning

Caution

1.1 Description

- 1.1.1 The Airflex 229DBAT is a spring-applied, air-released dual disc brake, designed to provide braking on Reynolds Mark III D & I Presses. The brake is designed to develop greater torque and faster response over the current clamshell brake, which should result in prolonged tooling life. Also, since the 229DBAT has a greater volume of friction material over the clamshell design, frequency of adjustment will be reduced.

- 1.1.2 Included with the brake retrofit kit (P/N 107465) are four, Airflex Diaphragm Quick Release Valves for installation on the clutch. These valves respond much faster than the previous design, and will allow full benefit of the increased brake torque by minimizing clutch/brake overlap.

1.2 How it Works

- 1.2.1 Throughout this manual a number given in parenthesis (#) refers to parts identified in and **Figure 1 and Figure 2** & Table 1.
- 1.2.2 The brake is spring-applied and air-released. When the air pressure is exhausted, the spring force “clamps” the friction discs (5) between the pressure plate (7), reaction plate (23) and mounting flange (1). The friction discs are mounted to ring gears (84) which slide on the gear (22) attached to the crankshaft. As air pressure is applied through the end plate (12) and into the diaphragm (11) cavity, the end plate moves away from the stationary spring housing (8). The pressure plate (7) is bolted to the end plate and travels in the same direction with it, compressing the springs (19) (20) and relieving the clamping force from the friction discs.

2.0 INSTALLATION

Note: Some rework of the timing belt sealing plate, locknut (61) and machine guard will be required to provide adequate clearance for the brake. Also, on a few of the newer machines, tapped holes may have to be added to the bearing housing flange. It is recommended Reynolds Metals Company, Can Division Engineering, Richmond, Virginia, be contacted for specific instructions.

Warning

Prior to installation of the brake, make sure the machinery is in, and will remain in, a secured position. Failure to do so could result in serious personal injury.

Caution

Before performing any work, study this manual completely. Know what needs to be done. Do not risk injury- follow the instructions.

Caution

Excessive air pressure can cause diaphragm (11) or end plate (12) failure. Do not apply air pressure greater than 120 PSIG. On the other hand, insufficient air pressure can cause the brake to only partially release, generating heat and possible damage. The minimum operating air pressure is 60 PSIG.

2.1 Removal of Existing Clamshell Brake

- 2.1.1 Referring to **Figure 2**, remove the lube oil rotary union (not shown), the timing belt (not shown), the timing belt sheave (60), and the locknut (61). Disconnect the air supply line from the brake cylinder.
- 2.1.2 Loosen the locknuts on the existing brake spring rods enough to relieve all spring tension.
- 2.1.3 Remove the two locknuts (62) and washer (63) from the end of the reaction pin (64), and slide the brake assembly off of the drum (65).
- 2.1.4 Remove the drum (65) from the end of the crankshaft. A puller, and possibly heat, will be required. Two, 1"-8 NC-2 tapped holes are provided in the face of the drum hub to accommodate a puller.
- 2.1.5 Remove the reaction pin and bracket assembly (66).
- 2.1.6 Remove and rework the timing belt sealing plate per Reynolds' instructions.
- 2.1.7 Add tapped holes in the bearing housing flange, if required (see note at 2.0).

2.2 Disassembly of the 229DBAT Brake

Although the brake can be installed as a complete assembly, the size and weight of the unit make it a cumbersome task. Partial disassembly and installation "in pieces" has proven to save considerable time and effort.

Warning

Follow the disassembly instructions closely! Removal of the incorrect fasteners may result in flying projectiles (bolts) from the high spring forces.

- 2.2.1 With the brake laying flat on the mounting flange (1), remove the 12 lockouts (9) and washers (44), alternating from locknut to locknut, and in increments of 1/2 of the exposed stud length. See **Figure 4** for proper sequence.

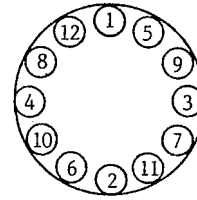

Figure 4

Caution

If a stud (2) comes loose from the mounting flange (1), clean the stud threads thoroughly, and reinstall in the mounting flange using Loctite 277, or equivalent, on the threads. Thread the stud into the mounting flange until it bottoms.

- 2.2.2 Carefully lift the pressure plate (7), spring housing (8) and end plate (12) sub-assembly off of the studs, and set aside. Two 1" diameter holes are provided in the spring housing for lifting.
- 2.2.3 Remove the friction disc/ring gear assemblies (5)(84) and the reaction plate (23).

Caution

When handling the friction discs (5), avoid getting grease or oil on the friction material. Grease or oil contamination will result in loss of brake torque and degraded performance.

2.3 Installation of the 229DBAT Brake

- 2.3.1 Rework the locknut (61) per Reynolds' specifications.
- 2.3.2 Make sure the tapered end of the crankshaft, the bore in the gear (22) and the bearing housing flange (67) are clean, and free of nicks and burrs.
- 2.3.3 Slide the gear onto the crankshaft and install and tighten the reworked locknut (61). Check that the gear has pulled completely onto the taper. See **Figure 3** for reference dimensions. Tighten the locknut cap screws.
- 2.3.4 Install the mounting flange (1), stud (2), clamp tube (3) and wear spacer assembly (25), securing it to the bearing housing flange (67) with nine, 3/4"-10 NC-2 x 3.50" long cap screws and lockwashers (customer provided). Torque the cap screws to 148 ft-lb.
 - 2.3.4.1 The eye bolt (86) is provided in the mounting flange for lifting purposes. When properly installed, the eye bolt will be at the 12 o'clock position and the oil drain slot on the back side of

the mounting flange (1) will be at the 6 o'clock position.

- 2.3.5 Coat the gear (22) teeth with a thin coat of Molub-Alloy 0.G. Heavy grease or equivalent. This ensures proper movement of the friction disc/ring gear assemblies (5) (84).
- 2.3.6 Slide the friction disc/ring gear assembly onto the gear and against the mounting flange.

Caution

Refer to Figure 5 and note the proper orientation of friction discs (5) and ring gears (84). When properly installed, the heads of the screws attaching the friction discs to the ring gear must face each other.

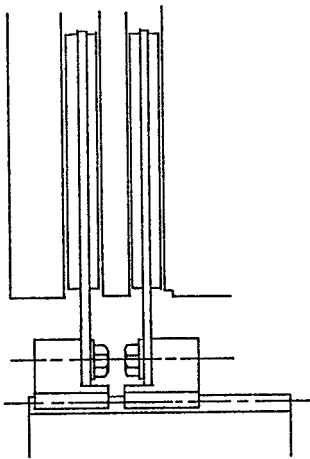

Figure 5

- 2.3.7 Slide the reaction plate (23) over the studs (2) and clamp tubes (3), and against the friction disc.
- 2.3.8 Install the 2nd friction disc/ring gear assembly, noting the proper orientation of the bolt heads.
- 2.3.9 Slide the pressure plate, spring housing, end plate sub-assembly over the clamp tubes.
- 2.3.9.1 Two, 1" diameter holes are provided in the spring housing for lifting. The letter "A" is stamped at one location on the mounting flange (1), and at one location on the spring housing (8). Lift by the hole that will "match the A's" when installed.
Note: Alignment of the brake components is essential for proper location of the air connection fitting.
- 2.3.10 While supporting the weight of the pressure plate, spring housing and end plate sub-assembly, coat the threaded ends of the studs (2) with 30 weight oil or anti-seize compound, and install the locknuts (9) and washers (44), tightening the locknuts in an alternating pattern as shown in

Figure 4, and screwing the locknuts no more than two turns at a time. Torque the locknuts to 500 ft-lb, lubed.

Caution

The weight of the pressure plate, spring housing, and end plate sub-assembly must be supported during this operation. If not supported, the studs and clamp tubes may sag slightly, causing binding of the reaction plate (23) on the clamp tubes (3) during operation.

- 2.3.11 After the locknuts have been tightened, it is no longer necessary to support the weight of the pressure plate, spring housing and end plate sub-assembly.
- 2.3.12 Connect the flexible air line from the solenoid valve to the air fitting on the brake. Apply 60 psi minimum/120 psi maximum to the brake and check for air leaks and/or any binding of the reaction plates (23) or friction discs (5).

Warning

Do not stand in line with the Quick Release Valve (54) air stream. Particles picked up by the air stream may cause personal injury.

Caution

A flexible air line MUST be used between the solenoid valve and the brake air fitting.

- 2.3.13 Reinstall the timing belt pulley (60) and the lube oil rotary union. Install, align and tension the timing belt.

2.4 Installation of the Clutch Quick Release Valves

- 2.4.1 Disconnect the air bridge (68) from the clutch element (69) taking care not to lose the rubber gaskets (70) at the air inlets.
- 2.4.2 Loosen the tubing nut (71) and withdraw the air connection tube (72).
- 2.4.3 Unscrew the quick release valve (73) from the element (69).
- 2.4.4 Apply a good quality pipe thread sealant to the threads on the new quick release valve, and screw into the element until the air connections are aligned. See Figure 6. Use a wide, flat faced wrench which will not crimp or damage the valve body.

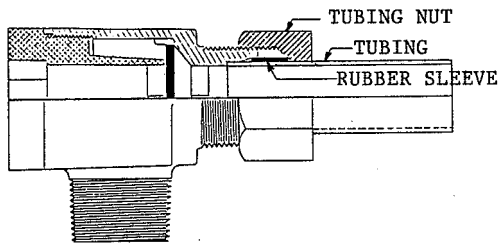

Figure 6

- 2.4.5 Loosen the tubing nut and insert the air connection tube completely into the valve, making sure not to damage the rubber sealing sleeve. A small amount of oil on the air connection tube will make insertion into the valve easier. Tighten the tubing nut.
- 2.4.6 Reinstall the air bridge (68) making sure the rubber gaskets (70) are in place at the air inlets.
- 2.4.7 Apply 60 psi minimum/120 psi maximum to the clutch and check for leaks.

Warning

Do not stand in line with the exhaust air stream. Particles picked up by the air stream may cause personal injury.

- 2.4.8 For additional information on the Airflex Diaphragm-Operated Quick Release Valve, request Airflex Manual QRV 9100 "Installation, Operation and Maintenance of the Airflex Quick Release Valve".

Note: With the air bridge disconnected, an ideal opportunity exists to check the condition of the clutch. Note excessive wear or grease contamination, and replace parts as required. The complete part number for the clutch element is 145643HF. Replacement parts are available from Airflex, or any Airflex Authorized Distributor in your area.

3.0 OPERATION

- 3.1 Run the machine for several minutes without feeding cups and check for any binding of the reaction plate (23) or dragging of the friction discs (5).
- 3.2 Execute the top stop control several times and note the stopping position. Readjust timing if necessary.

Note: Due to inherent characteristics of the friction material, the brake may not develop full torque initially; however, the initial developed torque will be, at the very least, equal to the full developed torque of the previous clamshell brake. After the brake has worked for a short time and has "worn-in", full torque will be developed.

- 3.3 If the area around the brake involves periodic "washdown", avoid spraying into the brake. Water, detergent, coolant, oil, etc., may contaminate the friction material, resulting in a reduction of developed brake torque.

Caution

In normal operation of this product, some dust may be generated as the friction material wears. This dust is not toxic, but like any other dust, it may irritate the respiratory system if inhaled. It is a good housekeeping practice to clean up this dust by vacuuming, or with a damp rag. Do not use compressed air or dry sweeping.

4.0 MAINTENANCE

Warning

Prior to performing any maintenance on the brake, make sure the machinery is in, and will remain in, a secured position. Failure to do so could result in serious personal injury.

Caution

Before performing any work, study this manual and the brake figures carefully. Do not risk injury - follow the instructions.

4.1 Wear Adjustment:

As the brake wears, developed brake torque will gradually diminish. To restore full developed brake torque, simple adjustments are required.

- 4.1.1 Referring to **Figure 7**, Dimension "B", which is the gap between the pressure plate (7) and mounting flange (1) faces, will gradually diminish as the friction material wears. The 229DBAT is supplied with wear spacers (25), which allow for two wear adjustments before replacement of the friction discs is required. Adjustment is required when the "B" dimension shown on **Figure 7** is LESS than the values shown below. Note: the "B" dimension is measured with the brake engaged (air off).

Original "B" dimension (new) = 2.500 in.

1st adjustment when "B" = 2.344 in.

2nd adjustment when "B" = 2.188 in.

Replace friction discs and spacers when "B" = 2.032 in.

Warning

If a wear adjustment is not made when required, the end plate (12) will eventually bottom against the spring housing (8), resulting in a rapid deterioration of developed brake torque.

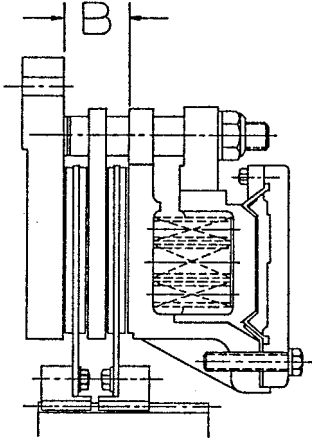

Figure 7

- 4.1.2 Removal of the wear spacers does not require disassembly of the brake. To remove, loosen the locknuts (9) in alternating sequence and no more than two turns at a time, until the spring pressure is relieved. See **Figure 4** for proper sequence.

Caution

If a stud (2) comes loose from the mounting flange (1), clean the stud threads thoroughly, apply Loctite 277 or equivalent and thread it back into the mounting flange hole until it bottoms.

- 4.1.3 With a chisel, “cut out” one spacer from each stud, as shown in **Figure 8**.

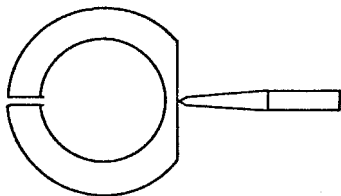

Figure 8

- 4.1.4 Reassemble per 2.3.10.

4.2 Replacement of Friction Discs (5)

Both friction discs (5) must be replaced when any of the following conditions exist:

1. The “B” dimension is less than 2.032 In.

2. Any one, or both, of the discs become oil-contaminated, and the brake will not develop full torque when properly adjusted.

3. Any friction block has worn to a minimum thickness of .200”, as shown on **Figure 9**.

Caution

When handling the friction material, avoid getting grease or oil on the working surfaces. Grease or oil contamination may result in a significant loss of developed brake torque and decreased brake performance.

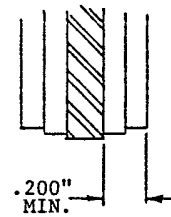

Figure 9

- 4.2.1 Remove the pressure plate, spring housing and end plate sub-assembly (7) (8) (12) per 2.2.1.
- 4.2.2 Remove the friction disc/ring gear assemblies (5) (84) and the reaction plate (23).
- 4.2.3 Inspect the gear (22) and ring gears (84) for excessive wear. Replace as required.
- 4.2.4 The friction discs are attached to the ring gears with (18) 5/8”-11 NC-2 alloy screws and flat washers (82)(83). Apply Loctite 242 to the screw threads and torque to 70 ft-lb.

Warning

The friction discs are attached to the ring gears with alloy screws. **DO NOT** use commercial (Grade 2) fasteners. Use of commercial fasteners may result in total brake failure and serious equipment damage or personal injury.

- 4.2.5 Reassemble the brake per 2.3.

4.3 Replacement of the Diaphragm (11)

- 4.3.1 With the brake mounted on the machine, disconnect the flexible hose from the air fitting and remove eight hex head screws (16) and lock washers (17) from the end plate.
- 4.3.2 Carefully remove the end plate (12), diaphragm (11), inner clamp ring (13), and outer clamp ring (10) as an assembly.
- 4.3.3 Place the end plate, with the diaphragm facing up, on a clean working surface. Remove twenty-four hex head screws (21) and lockwashers (15), and lift off the outer clamp ring (10).

- 4.3.4 Remove four hex head screws (14) and lock-washers (15), and lift off the inner clamp ring (13).
- 4.3.5 Replace the diaphragm (11).
- 4.3.6 Position the outer clamp ring segments (10) over the appropriate holes in the end plate. Apply Loctite 242 to the threads of the hex head screws (21) and assemble the flat washers (92) onto the screws. Install and tighten the screws to 20 ft-lb.
- 4.3.7 Position the inner clamp ring (13) over the holes in the end plate. Assemble the lockwashers (15) onto the hex head screws (14) and tighten to 20 ft-lb.
- 4.3.8 Clean the rubbing surfaces between the spring housing (8) and the diaphragm (11), and coat with Amsoil Long Life, Multi-Purpose, Moly-Compound Synthetic Grease.
- 4.3.9 Carefully place newly assembled end plate (12), diaphragm (11), outer clamp ring (10), and inner clamp ring (13) assembly on brake. Note that the four heads on the inner clamp ring cap screws (14) fit into recesses in the pressure plate (7). Also note the final position of the air connection.
- 4.3.10 Lubricate the threads of the hex head screws (16) with 30 weight oil or anti sieze compound and assemble the lockwashers (17) onto the screws. Install the screws and using the assembly sequence shown in **Figure 10**, tighten the screws to 150 ft-lb., lubed.

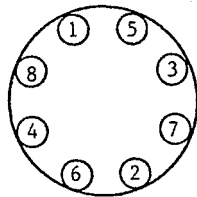

Figure 10

- 4.3.11 Reconnect the air hose and test for leaks.

4.4 Replacement of Springs (19) (20)

Warning

Prior to disengagement or removal of the brake, make sure the machinery is in, and will remain in, a secured position. Failure to do so may result in serious personal injury.

- 4.4.1 Remove the pressure plate (7), spring housing (8) and end plate (12) sub-assembly per 2.2.1, and lay on a flat work surface, with the end plate up.
- 4.4.2 Match mark (a paint stripe will suffice) the pressure plate, spring housing, and end plate.

- 4.4.3 Remove the hex head screws (16) and lock-washers (17) in alternating sequence, two turns at a time (Refer to **Figure 10**). With these removed, the end plate (12), diaphragm (11), outer clamp ring (10), inner clamp ring (13), hex head screws (14)(21) and lockwashers (15) can be removed as an assembly.
- 4.4.4 Remove the spring housing (8) exposing the springs (19)(20) and spring retainer plates (18).
- 4.4.5 Replace the springs (19)(20). The old retainer plates (18) may be reused. Refer to **Figure 11** and **Figure 12** for proper orientation.

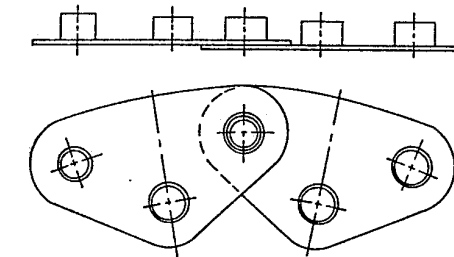

Figure 11

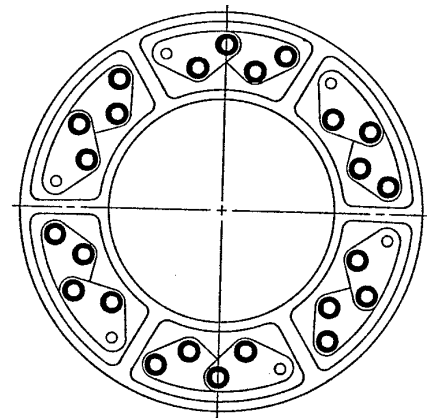

Figure 12

- 4.4.6 Clean the rubbing surfaces between the spring housing (8) and the pressure plate (7), and between the spring housing (8) and the diaphragm (11), and coat with Amsoil Long-Life, Multi-Purpose, Moly-Compound Synthetic Grease.
- 4.4.7 Align the match marks and carefully lower the spring housing (8) over the pressure plate (7).
- 4.4.8 Align the match marks and place the end plate (12)/diaphragm (11) assembly in position.
- 4.4.9 Lubricate the threads of the hex head screws (16) with 30 weight oil or anti sieze compound and assemble the lockwashers (17) onto the screws. Reassemble the end plate (12), spring

housing (8) and pressure plate (7) with hex head screws (16) and lockwashers (17), tightening the screws in alternating sequence, no more than two turns at a time, per **Figure 10** until seated.

- 4.4.10 Torque the screws to 150 ft-lb., lubed.
- 4.4.11 Reinstall the assembly onto the rest of the brake per 2.3.9.

5.0 ORDERING INFORMATION/TECHNICAL ASSISTANCE

5.1 Equipment Reference

- 5.1.1 In any correspondence regarding Airflex equipment, refer to the information on the product nameplate and call or write:

Eaton Corporation
Airflex Business Unit
9919 Clinton Road
Cleveland, Ohio 44144

Tel.: (216) 281-2211
Fax: (216) 281-3890
Internet: www.airflex.com

Loctite®, Locquic®, and Superflex® are registered trademarks of Henkel Corporation.

M0LUB-ALLOY® is a trademark of Castrol Industrial Lubricants.

EATON PRODUCT WARRANTY

Subject to the conditions stated herein, Eaton Corporation warrants to the Purchaser that each new Airflex Product manufactured by Eaton will be free from failures caused by defects in material and workmanship, and will deliver its rated capacity, for a period of twelve (12) months from the date of shipment to Purchaser, provided such Product is properly installed, properly maintained, operated under normal conditions and with competent supervision. Warranty claims shall, be made in writing and the part or parts shall, if requested by Airflex Division, be returned repaid to the Airflex Division for inspection. Upon a determination that a defect exists, Eaton shall thereupon correct any defect, at its option either by repairing any defective part or parts or by making available at Eaton's plant a repaired or replacement part. This warranty does not extend to normal wear parts or components of the Product, such as friction material and friction surfaces.

LIMITATION OF WARRANTY

THE FOREGOING WARRANTY IS EXCLUSIVE AND IN LIEU OF ALL OTHER WARRANTIES WHETHER WRITTEN, ORAL OR IMPLIED. ANY IMPLIED WARRANTY OF MERCHANTABILITY OR FITNESS FOR A PARTICULAR PURPOSE ARE SPECIFICALLY EXCLUDED.

In no event shall Eaton be liable for special, incidental or consequential damages. Eaton's liability arising out of the supplying of such Product, or its use, whether in warranty, contract or otherwise, shall in no case exceed the cost of correcting defects in the Products as herein provided. Upon expiration of the twelve (12) month period, all such liability shall terminate. **THE FOREGOING SHALL CONSTITUTE THE SOLE REMEDY OF PURCHASER AND THE SOLE LIABILITY OF EATON.**